

# Teaching AS Chemistry Practical Skills

**Your attention is drawn to the Risk Assessment section on page 15 of the Introduction to this booklet, and to the hazards indicated in Appendices 1 and 2. While every effort has been made to ensure that appropriate safety indications are given, CIE accepts no responsibility for the safety of these experiments and it is the responsibility of the teacher to carry out a full risk assessment for each experiment undertaken, in accordance with local rules and regulations. Hazard data sheets should be available from your suppliers.**

**Acknowledgements**

Thanks are due to Chris Conoley and Brian Hildick for writing this booklet.

## Contents

Introduction	1
Why should I read this booklet?	1
How much teaching time should I allocate to practical work?	1
Can I use the practicals in these booklets in a different order?	1
What resources will I need?	2
Is there a limit to the class size?	2
Why should I teach my students practical skills?	2
Points to consider	2
What are the practical skills required by this course?	3
Summary of each of the seven skills	5
Ways of doing practical work	8
Keeping records	12
How is a practical activity organised?	13
Risk assessment	15
Eye protection	16
AS skills	18
Teaching students to manipulate apparatus	18
Teaching students to make observations and measurements	18
Teaching students to record and present data and observations	19
Teaching students to analyse data and draw conclusions	20
Teaching students to evaluate procedures	21
Designing a practical course for the AS year	22
Appendix 1 – Suggested AS level practical course	23
Appendix 2 – Detailed practical lessons	39
1. Making salt – an introduction to some basic techniques	39
3. How much iron is there in an iron tablet?	45
5. What is the volume of 1 mole of hydrogen gas?	49
8. Measuring the enthalpy changes of exothermic and endothermic reactions	52
12. The effect of altering the concentration on an equilibrium reaction	57
13. Determining the value of $K_c$ for an equilibrium reaction	61
15. The effect of temperature on reaction rate	67
21. Some redox reactions of halogens and halides	72
25. Cracking hydrocarbons	77
28. Some reactions of alcohols	81

## Introduction

You may have been teaching AS and A level chemistry for many years or this may be a new experience. In either case, you will be keen to ensure that you prepare your students as effectively as possible for their examinations. Using a well-structured scheme of practical work will certainly help you to achieve this, but it can do so much more. Scientists who are thoroughly trained and experienced in practical skills will have a 'feel' for the subject and be much more confident in their own abilities than those with a purely theoretical background. While it is true that there are branches of chemistry that could be described as purely theoretical, these are in the minority. Essentially, chemistry is a practical subject and we owe it to our students to ensure that those who pursue science further have the necessary basic practical skills to take forward into their future careers. Furthermore, the basic skills of planning, analysis and evaluation will be of great value to those who pursue non-scientific careers.

### Why should I read this booklet?

Some of you may be wondering why you need a booklet like this. If you have highly developed practical skills and you feel confident teaching these skills to others, you probably don't, but you might find some of the exercises described in the appendices useful. However, most of us appreciate a little help and support. This booklet aims to provide at least some of this support.

It is designed for the teacher rather than for the student. Its objective is to provide a framework within which your practical skills can develop and grow. Experience shows that as the teacher's practical skills develop, their confidence in teaching such skills increases, as does the amount of time that they will be prepared to spend on teaching practical work.

### How much teaching time should I allocate to practical work?

The syllabus stipulates that 20% of teaching time should be allocated to practical work. This is in addition to any time you choose to spend on practical demonstrations to illustrate the theory syllabus. This emphasis on practical work is not misplaced. Consider the weighting given to assessment objectives in the syllabus: 24% of the award is allocated to experimental skills and investigations and 30% is allocated to handling, applying and evaluating information. Taken together, almost 55% of the total award is related to the student's ability to interpret data, understand how it has been obtained, recognise limitations and suggest explanations. All of these objectives lend themselves to investigative work involving practical experience. Even if you consider the specific practical papers in isolation, they still represent 23% of the AS or 24% of the A2 award.

In planning a curriculum, you should therefore expect to build in time for developing practical skills. If, for example, the total time allowed for this syllabus is 5 hours per week over 35 weeks, then a minimum of 1 hour per week should be built into the plan for practical work, so that over the year a minimum of 35 hours is made available – 20% of the total. Bearing in mind the emphasis on assessment objectives that relate to information handling and problem solving, a minimum of 2 hours per week might be more appropriate, which at 40% of the total time is still less than the overall weighting for these assessment objectives.

### Can I use the practicals in these booklets in a different order?

It is assumed that for A level candidates, the AS work will be taught in the first year of the course and the A2 work will be covered in the second year. If you take this linear A level assessment route, you need to give careful consideration to the order in which you use the practical exercises, as the skills practised in these booklets are hierarchical in nature, i.e. the

basic skills established in the AS booklet are extended and developed in the A2 booklet. Thus, students will need to have practised basic skills from the AS exercises before using these skills to tackle more demanding A2 exercises.

The exercises in the booklets are given in syllabus order. You may, of course, decide to use a different teaching sequence, but the above point regarding AS/A2 exercises still applies.

### **What resources will I need?**

For a practical course in A level chemistry to be successful, it is not necessary to provide sophisticated equipment. The vast majority of the practicals in these booklets can be performed using the basic equipment and materials already in the laboratory. However, some of the more advanced practicals may require less easily obtainable equipment. Alternative, 'low-tech' exercises are also provided where possible.

A list of the basic resources required for assessment can be found in the syllabus. A more detailed list can be found in the booklet *CIE Planning for Practical Science in Secondary Schools*, Appendix B.

### **Is there a limit to the class size?**

There is a limit to the number of students that you can manage in a laboratory situation, particularly when students may be moving about. Your particular class size may, of course, be determined by the size of the room. As a general guide, however, 15 to 20 students is the maximum number that one person can reasonably be expected to manage, both for safety reasons and so that adequate support can be given to each student. Larger numbers will require either input from another person with appropriate qualifications or splitting the class into two groups for practical lessons.

## **Why should I teach my students practical skills?**

Although teachers are likely to read this section only once, it is arguably the most important. If it convinces the 'non-practical' chemistry teacher that practical work is an essential part of chemistry and that it underpins the whole teaching programme, the aim of publishing this booklet will have been achieved.

### **Points to consider**

- It's fun! The majority of students thoroughly enjoy practical work. The passion that many scientists have for their subject grew out of their experiences in practical classes. Students who enjoy what they are doing are likely to carry this enthusiasm over into other areas of their work and so will be better motivated.
- Learning is enhanced by participation. Students tend to find it easier to remember activities they have performed, which benefits their long-term understanding of the subject. Students who simply memorise and recall facts find it difficult to apply their knowledge to an unfamiliar context. Experiencing and using practical skills helps to develop people's ability to use information in a variety of ways, thus practical work also enables students to apply their knowledge and understanding more readily.
- Integrating practical work into the teaching programme quite simply brings the theory to life. Teachers often hear students making comments like 'I'm glad we did that practical because I can see what the book means now' and 'It's much better doing it than talking about it.'

- Chemistry, physics and biology are, by their very nature, practical subjects – both historically and in the modern world. The majority of students who enter careers in science will need to employ at least basic practical skills at some time in their career. Those who pursue non-scientific careers will also benefit from acquiring transferable practical skills and safety awareness.
- A practical course develops many cross-curricular skills, including literacy, numeracy, ICT and communication skills. It develops the ability to work both in groups and independently, and with confidence. It enhances critical thinking skills and it requires students to make judgements and decisions based on evidence, some of which may well be incomplete or flawed. It helps to make students more self-reliant and less dependent on information provided by the teacher.
- The skills developed are of continuous use in a changing scientific world. While technological advances have changed the nature of practical procedures, the investigative nature of practical science remains unchanged. The processes of observation, hypothesis formation, testing, analysing results and drawing conclusions will always be the processes used in investigative science. The ability to keep an open mind in the interpretation of data and to develop an appreciation of scientific integrity is of great value in both science and non-science careers.
- Practical work is not always easy, and persistence is required for skills to develop and for confidence to grow. Students often relish this challenge and develop a certain pride in a job well done.
- The more experience students have of using a variety of practical skills, the better equipped they will be to perform well in the practical exams, both in terms of skills and confidence. While it could be argued that the required skills could be developed for paper 3 simply by practising past examination papers, the all-round confidence in practical ability will be greatly enhanced by wider experience. Similarly for paper 5, while it could be argued that planning, analysis and evaluation can be taught theoretically, without hands-on experience of manipulating their own data, putting their plans into action and evaluating their own procedures and results, students will find this section difficult and will be at a distinct disadvantage in the examination. Those students who can draw on personal experience, and so are able to picture themselves performing the procedure they are describing or recall analysing their own results from a similar experiment, are much more likely to perform well than those with limited practical skills.

## What are the practical skills required by this course?

This course addresses seven practical skills that contribute to the overall understanding of scientific methodology. In a scientific investigation these would be applied in this sequence:

1. **Planning the experiment**
2. **Setting up/manipulating apparatus**
3. **Making measurements and observations**
4. **Recording and presenting observations and data**
5. **Analysing data and drawing conclusions**
6. **Evaluating procedures**
7. **Evaluating conclusions**

The syllabus shows how these seven skills are assessed, and the structure is common to all three sciences. The emphasis of the AS level syllabus is on developing an understanding of, and practice in, scientific procedures, data collection, analysis and drawing conclusions. It also starts to develop students' skills in critical evaluation of experimental procedures by asking them to suggest improvements to the procedures. In general, students find performing practical procedures and collecting data more accessible than analysis, while evaluation is the skill that is least readily accessible. To enable access to these more demanding skills, students need to understand why an experimental procedure is carried out in a particular way so that they can recognise sources of error or limitations that could affect the reliability of their results. Students will not be able to evaluate until they can critically review a practical procedure.

The A2 syllabus builds upon the skills developed at AS level. Its emphasis is on the higher-level skills of planning, analysis and evaluation. In order to plan effectively, students need to be able to evaluate procedures and critically assess results. This is best achieved by performing practical exercises, starting at AS level with relatively straightforward and familiar contexts and developing at A2 level by using more complex procedures and less familiar contexts. Data analysis also develops from AS level into more complex treatments, so students need to be provided with opportunities to gather suitable data and perform the appropriate manipulations. Evaluating conclusions and assessing procedures are very high-order skills. Students who have not had sufficient opportunity to plan and trial their own investigations will find these skills difficult. While students are not expected to be able to plan perfectly, they are expected to recognise weaknesses and make reasonable suggestions for improvement. The best learning tool for developing these skills is to devise a plan, carry out the investigation and then assess how well the planned procedure worked. The syllabus gives detailed guidance on the expected skills and learning outcomes.

In summary, Skills 2 to 6 listed above will be assessed at AS level. The first and last will only be assessed at A2 level, and A2 will also take Skills 5 and 6 to a higher level.

The above list shows the seven skills in the order in which they would be used in an extended investigation. It is not suggested that you teach these skills in this order, nor would it be wise. Students who are new to practical work will initially lack the basic manipulative skills, and the confidence to use them. It would seem sensible, therefore, to start practical training with Skill 2, initially with very simple tasks, paying attention to establishing safe working practices.

Once a measure of confidence in AS students' manual dexterity has been established, they can move on to exercises that require Skills 3 and 4 to be included. Extensive experience in carrying out practical procedures allows students to gain awareness of appropriate quantities and to become more organised in time management and recording data as it is collected.

It is likely that Skill 6, evaluating procedures, will be the most difficult to learn at AS level. Critical self-analysis does not come easily to many people. 'My experiment worked well' is a frequent response. If students are to master this skill, they need to develop an appreciation of the reliability and accuracy inherent in the equipment and procedure they are using. Only then will they be able to identify anomalous results, or results that fall outside the 'range of uncertainty' intrinsic in the apparatus they chose to use and which must therefore be considered inaccurate. Exercises with less reliable/accurate outcomes can be used to provide more scope for evaluating errors that result from procedure, technique or apparatus.

Planning is arguably the most demanding of the seven skills. For planning to be effective, students need to be very well grounded in Skills 2 to 6 so that they can anticipate the different stages involved in the task and can provide the level of detail required. It is for this reason that planning skills are not assessed at AS level but form part of the A2 assessment in paper 5. Students do not develop an understanding of how apparatus works and the sort

of measurements that can be made using particular types of apparatus unless they use it. They cannot be taught to plan experiments effectively unless, on a number of occasions, they are required to:

- plan an experiment;
- perform the experiment according to their plan;
- evaluate what they have done.

Skill 7, evaluating conclusions, is achieved by comparing the outcome of an exercise with the predicted outcome, and so is also an A2 skill. It should be taught and practised as part of the planning exercises.

### Summary of each of the seven skills

Full details of the requirements for each of these skills can be found on pages 34 to 41 of the syllabus. The following is a brief summary of the skills involved.

#### 1. Planning the experiment

- **Defining the problem**

Students should be able to use information provided about the aims of the investigation, or experiment, to identify the key variables. They should use their knowledge and understanding of the topic under consideration to make a quantitative, testable prediction of the likely outcome of the experiment.

- **Methods**

The proposed experimental procedure should be workable. Given that the apparatus has been assembled appropriately, the procedure should allow data to be collected without undue difficulty. There should be a description, including diagrams, of how the experiment should be performed and how the key variables will be controlled. Equipment, of a level of precision appropriate for the measurements to be made, and quantities of materials to be used should be specified. The use of control experiments should be considered.

- **Risk assessment**

Students should be able to carry out a simple risk assessment of their plan, identifying areas of risk and suggesting suitable safety precautions.

- **Planning for analysis, conclusions and evaluation**

Students should be able to describe the main steps by which their results will be analysed in order for valid conclusions to be drawn. This may well include generating a results table and proposing graphical methods for analysing data. They should also propose a scheme for interpreting and evaluating the results and the experimental procedure employed to obtain those results. They should indicate how the outcomes of the experiment will be compared with the original hypothesis.

#### 2. Setting up/manipulating apparatus

It is important that students are allowed sufficient time and opportunity to develop their manipulative skills to the point where they are confident in their approach to experimental science. They must be able to follow instructions, whether given verbally, in writing or diagrammatically, and so be able to set up and use the apparatus for experiments correctly.



### 3. Making measurements and observations

- **Measuring/observing**

While successfully manipulating the experimental apparatus, it is crucial that students are able to take measurements with accuracy and/or to make observations with clarity and discrimination. Accurate meter or burette readings and precise descriptions of colour changes and precipitates will make it much easier for students to draw valid conclusions, and to attain a higher score in the test.

- **Deciding on what measurements/observations to make**

Time management is important, so students should be able to make simple decisions on the number and range of tests, measurements and observations that can be made in the time available. For example, if the results of the first two titrations were in good agreement, there would be no need to carry out a third.

Students need to be able to make informed decisions regarding the appropriate distribution of measurements within the selected range, which may not always be uniform, and the timing of measurements made within the experimental cycle. They should also be able to identify when repeated measurements or observations are appropriate.

They should practise the strategies required for identifying and dealing with results that appear anomalous.

### 4. Recording and presenting observations and data

An essential, but frequently undervalued, aspect of any experimental procedure is communicating the results to others in a manner that is clear, complete and unambiguous. It is vital that students are well practised in this area.

- **The contents of a results table**

The layout and contents of a results table, whether for recording numerical data or observations, should be decided before the experiment is performed. 'Making it up as you go along' often results in tables that are difficult to follow and do not make the best use of space. Space should be allocated within the table for any data manipulation that will be required.

- **The column headings in a results table**

The heading of each column must be clear and unambiguous. In columns that will contain numerical data, the heading must include both the quantity being measured and the units in which the measurement is made. The manner in which this information is given should conform to 'accepted practice'.

- **The level of precision of recorded data**

It is important that all data in a given column is recorded to the same level of precision, and that the level of precision is appropriate for the measuring instrument used.

- **Display of calculations and reasoning**

Where students use calculations as part of the analysis, all steps of the calculations must be displayed so that thought processes involved in reaching the conclusion are clear to a reader. Similarly, where students draw conclusions from observational data, the key steps in reaching the conclusions should be reported and should be clear, sequential and easy to follow.

- **Significant figures**

Students should be aware that the number of significant figures to which the answer is expressed shows the precision of a measured quantity. Therefore, they should take great care with regard to the number of significant figures quoted in a calculated value. The general rule is to use the same number of significant figures as (or, at most, one more than) that of the least precisely measured quantity.

- **Data layout**

Students should be able to make simple decisions concerning how best to present the data they have obtained, whether this is in the form of tabulated data or as a graph. When drawing tables, they should be able to construct the table to give adequate space for recording data or observations. When plotting graphs, they should be able to follow best practice guidelines for choosing suitable axis scales, plotting points and drawing curves or lines of best fit.

## 5. Analysing data and drawing conclusions

This skill requires students to apply their understanding of underlying theory to an experimental situation. It is a higher-level skill and so makes a greater demand on the student's basic understanding of the chemistry involved. Even when that understanding is present, however, many students still struggle. Presenting a clear, lucid, watertight argument does not come naturally to most people and it is therefore recommended that students have a lot of practice in this area.

- **Interpreting data or observations**

Once data has been presented in the best form for analysis of the results of the experiment, students should be able to describe and summarise any patterns or trends shown and the key points of a set of observations. Further values, such as the gradient of a graph, may be calculated or an unknown value may be found, for example from the intercept of a graph.

- **Errors**

Students should be used to looking at an experiment, assessing the relative importance of errors and, where appropriate, expressing these numerically. They should be aware of two kinds of error:

- (i) The 'error' that is intrinsic in the use of a particular piece of equipment. Although we refer to this as an equipment error, we really mean that there is a 'range of uncertainty' associated with measurements made with that piece of equipment. This uncertainty will be present no matter how skilled the operator might be.
- (ii) Experimental error, which is a direct consequence of the level of competence of the operator or of the effectiveness of the experimental procedure.

- **Conclusions**

Students should learn to use evidence to support a given hypothesis, to draw conclusions from the interpretation of observations, data or calculated values, and to make scientific explanations of their data, observations and conclusions. Whatever conclusions are drawn, they must be based firmly on the evidence obtained from the experiment. At the highest level, students should be able to make further predictions and ask appropriate questions based on their conclusions.

## 6. Evaluating procedures

Arguably, this is one of the most important, and probably one of the most difficult, skills for students to develop. In order for the evaluation to be effective, students must have a clear understanding of the aims and objectives of the exercise, otherwise they will not be able to judge the effectiveness of the procedures used. They must be able to evaluate whether any errors in the data obtained exceed those expected due to the equipment

used. If this is the case, they then need to identify those parts of the procedure that have generated these excess errors and suggest realistic changes to the procedure that would result in a more accurate outcome. They should also be able to suggest modifications to a procedure to answer a new question.

The evaluation procedure may include:

- (i) the identification of anomalous values, a deduction of possible causes of these anomalies and suggestions for appropriate means of avoiding them;
- (ii) an assessment of the adequacy of the range of data obtained;
- (iii) an assessment of the effectiveness of the measures taken to control variables;
- (iv) an informed judgement on the confidence with which conclusions may be drawn.

## 7. Evaluating conclusions

This is also a higher-level skill, which demands that students have a thorough understanding of the basic theory that underpins the science involved.

The conclusions drawn from a set of data may be judged on the basis of the strength or weakness of any support for, or against, the original hypothesis. Students should be able to use the detailed scientific knowledge and understanding they have gained in theory classes to make judgements about the reliability of the investigation and the validity of the conclusions they have drawn.

Without practice in this area, students are likely to struggle. To increase their confidence in drawing conclusions, it is recommended that practical exercises, set within familiar contexts, are used to allow students the opportunity to draw conclusions, make evaluations of procedures and assess the validity of their conclusions.

In the examination, students may be required to demonstrate their scientific knowledge and understanding by using it to justify their conclusions.

## Ways of doing practical work

Science teachers should expect to use practical experiences as a way to enhance learning. Practical activities should form the basis on which knowledge and understanding are built. They should be integrated with the related theory, offering opportunities for concrete, hands-on learning rather than treated as stand-alone experiences. In planning a scheme of work, it is important to consider a mosaic of approaches that include those that allow students to participate in their own learning.

- Some practical activities should follow a well-established structure that includes a detailed protocol for students to follow. Such well-structured learning opportunities have a vital role to play in introducing new techniques, particularly in rapidly developing fields such as biotechnology. In these new areas of science, teachers often find themselves leading practical work that they did not have the chance to experience themselves as students.
- Other practical activities should offer students the opportunity to devise their own methods or to apply the methods that they have been taught to solving a problem. The excitement generated by exposure to 'new' and unfamiliar techniques provides a stimulus that will engage students' interest and challenge their thinking.

Practical activities may be used as a tool to introduce new concepts – for example, introducing catalysis by experimentation, followed up by theoretical consideration of the reasons for the unexpected results obtained. On other occasions, practical work can be

used to support and enhance the required knowledge and understanding – for example, in building upon a theoretical consideration of the limiting factors of photosynthesis with a series of practicals investigating the effect of light intensity and hydrogen carbonate concentration on photosynthesis in water weed. In all cases, learning will be enhanced most effectively by practical work that encourages students to be involved and to think, and to apply and use their knowledge, understanding and skills.

Practical work does not always have to be laboratory based. In classrooms, using models, role-play and paper cut-outs to simulate processes can be equally valuable. In biology, field studies also contribute greatly to a student's appreciation.

There are many strategies you can adopt to integrate practical work into a scheme of work. You should use a wide range of methods to enhance a variety of subject-specific skills and simultaneously develop a variety of transferable skills that will be useful throughout students' future professional lives. Some of the methods you can use to deliver practical work also enable you to interact on a one-to-one basis with individual students. This allows you to offer support at a more personal level and develop a greater awareness of an individual student's needs.

Your choice of a specific strategy will depend on issues such as class size, laboratory availability, availability of apparatus, level of competence of your students, availability and expertise of technical support, time available, your intended learning outcomes for the activity and safety considerations. The following are some possible strategies for delivering practical work:

- **Teacher demonstrations**

These require less time than a whole-class practical, but give little opportunity for students to develop manipulative skills or to become familiar with equipment. Careful planning can provide an opportunity for limited student participation. Teacher demonstrations are a valuable way of showing an unfamiliar procedure at the start of a practical session, during which students go on to use the method.

**Considerations** in choosing to do a demonstration **might include** the following:

- (i) **Safety** – some exercises carry too high a risk factor to be performed in groups.
- (ii) **Apparatus** – you may need to show complicated procedures or you may have limited resources.
- (iii) **Time** – demonstrations usually take less time.
- (iv) **Outcome** – some results are difficult to achieve and may be beyond the skill level of most students. A failed experiment may be seen as a waste of time.
- (v) **Students' attention** – a danger is that the attention of some students will drift.
- (vi) **Manipulative experience** – remember that with this strategy, the teacher gets experience, the students don't.

There are many good reasons for the teacher to perform a demonstration, but do be aware that most students have a strong preference for hands-on experimentation. So, where possible, let them do it!

- **Group work**

**Whole-class practical sessions.** These have an advantage in terms of management as all the students do the same thing. Students may work individually, in pairs or in small groups. Integrating this type of practical is straightforward as earlier lessons can be used to introduce the context and subsequent lessons can be used to draw any conclusions and develop evaluation. However, this approach may not be feasible where specialised equipment or expensive materials are in short supply.

**Small-group work.** This can provide a means of utilising limited resources or managing investigations that test a range of variables and require that a lot of measurements are collected. Although the same procedure may be performed, each student group collects only one or a few sets of data, which are then pooled. For example, if five concentrations of the independent variable are being tested, each of which needs to be measured at 2-minute intervals for 30 minutes, then a group of five students can each test one concentration. In biology, field studies also lend themselves to group activities as a lot of data has to be collected in a short period of time. The individual student has the opportunity to develop their subject-specific skills. Part of the teacher's role is to monitor and maintain safety and to enable and persuade reluctant learners to take part. Group work aids personal development as students must interact and work co-operatively.

**Considerations might include:**

- (i) **Learning** – successful hands-on work will reinforce understanding and students will also learn from each other.
- (ii) **Confidence** – this will grow with experience.
- (iii) **Awareness/insight** – this should grow with experience.
- (iv) **Team building** – this is a very desirable outcome.
- (v) **Setting out** – as all students are doing the same thing, it is easier for the technicians.
- (vi) **Confusion** – incomplete, ambiguous or confusing instruction by the teacher will result in wasted time while the instructions are clarified, and may also compromise safety and restrict learning.
- (vii) **Opting out** – some students will leave others to do the procedure and so learn very little.
- (viii) **Safety** – this could be a serious issue and constant vigilance is essential.
- (ix) **DIY** – the urge to adapt their experiments, to see 'what would happen if', must be dealt with strictly.
- (x) **Discipline** – practical time must not be allowed to become 'play time'.

Working in groups, whether as part of a whole-class situation or where groups are working on parts of a whole, is probably the preferred option for many students. At A level, however, it is highly desirable to include opportunities for students to work on their own, thus developing individual skills and independence. In paper 3, students' practical skills will be assessed on an individual basis, so each student's experience, competence and confidence are of considerable importance.

- **Circus of experiments**

A circus comprises a number of different exercises that run alongside each other. Individuals or groups of students work on the different exercises and as they complete each exercise, they move on to the next. These are a means by which limited resources can be used effectively.

There are two basic approaches. Most commonly, during a lesson a number of short activities are targeted at a specific skill. Alternatively, a number of longer practical activities are undertaken over a series of lessons, to address a variety of skills. The circus arrangement may be more difficult for the teacher to manage as the students are not all doing the same activity. This puts more pressure on the teacher as they have to cope with advising and answering questions from a variety of investigations. With circuses spread over a number of sessions, careful planning is needed to enable the teacher to engage each group of students and to maintain a safe environment. In these situations, it is useful to include at least two activities that do not involve hands-on practical work – using data response based simulations or other activities – so that the teacher can interact with the groups that need a verbal introduction or short demonstration and can monitor their activities more effectively.

**Considerations might include:**

- (i) **Apparatus** – if the amount of apparatus needed for an exercise is limited, students are able to use it in rotation.
  - (ii) **Awareness** – by observing their peers, students will become more aware of the pitfalls of the exercise and so will learn from the experience of others.
  - (iii) **Safety** – different exercises may well carry different safety risks, all of which need to be covered.
  - (iv) **Setting out** – students doing different exercises will make it more difficult for the technicians.
  - (v) **Opting out** – some students may be tempted to ‘borrow’ the results obtained by earlier groups.
- **Within theory lessons**  
This option should be considered whenever it is viable. It is likely that the practical work will be demonstrated, as this takes less time. Given the power of visual images, including a short practical to illustrate a theoretical point will reinforce the point and so aid the learning process. It is critical, however, that the practical works correctly, otherwise the flow of the lesson will be disrupted and confidence in the theory may be undermined. The teacher should therefore practise the exercise beforehand.
  - **Project work**  
Projects are a means by which a student’s interest in a particular topic, which is not always directly on the syllabus, can be used to develop investigative skills. It can also be used to access parts of the syllabus that have little laboratory-based investigation. For example, in gene technology students might use internet-based research to find examples of genetic modification and present a poster display showing the implications. This sort of investigative work can be undertaken as either an individual or a group activity. Once the project is underway, much of the work can be student-based, outside the classroom. Care is needed in selecting the topics and setting a timescale so that relevance to the syllabus context is maintained. The work can be directed towards producing posters, giving a presentation to the group or producing group or individual reports.
  - **Extra-curricular clubs**  
These can play a role in stimulating scientific enquiry methods. There are a number of ways of using clubs. One is to hold the club session during the teaching day so that all students can attend. In effect, this becomes additional lesson time in which students can practise investigative skills, including laboratory work. Such laboratory work involves materials that have a cost, which must be taken into consideration. Another way is to hold a club outside the teaching day, in which case it may be voluntary. Syllabus-specific activities should therefore be limited, but such clubs offer

valuable opportunities for exciting work unrelated to syllabuses. After-school clubs could be used as a vehicle for project work that is related to science and that is of social or economic importance, for example, endangered species or local mineral resources. Students who do attend the club could be used as a teacher resource by reporting their findings in a classroom session.

## Keeping records

Students often have a problem integrating the practical work with the theory. This is particularly true when a series of experiments or a long-term investigation or project is undertaken. Potential issues include the following:

- Some students use odd scraps of paper in the laboratory, which get lost or become illegible as chemicals are spilled on them. One important criterion is that students are trained to record results immediately and accurately.
- Practical procedures may be provided by the teacher, or students may write their own notes from a teacher demonstration. These notes may get lost, so students end up with results but no procedure or context.
- When results are collected over a period of time, analysis becomes isolated from the context of the investigation and may not be completed.

The key to minimising these issues is to train students into good work practices. This is particularly important in colleges where students join at the start of their A levels from a variety of feeder schools. It is also vital for students with specific learning difficulties that affect their ability to organise their work, such as dyslexia and Asperger's syndrome.

Students may be encouraged to integrate their practical notes with their theory notes and keep them all in one file. Alternatively, they may be encouraged to keep an entirely separate practical book or file. Loose-leaf files make it easy to add to their notes, but also make it easier to lose items. Exercise books can be used, but students should be encouraged to glue any protocols provided and their laboratory records into the book so that they do not get lost. Students can adopt whichever method they prefer, depending on how they learn. Whichever option they choose, they need to be encouraged to relate their investigations to the appropriate theory and to regard it as something that needs to be thoroughly assimilated.

- Integrating the materials generated by practical work with the notes from their learning of theory can be achieved by interspersing the records of investigations with the relevant section of theory. This may still require cross-referencing where work targets several learning outcomes and assessment objectives.
- Keeping a separate practical book enables students to keep records of all the practical investigations in one place. Students need training to manage practical files effectively, particularly in keeping the contexts and cross-referencing to the theory. If care is not taken to develop and maintain these skills, students may perceive practical work as something different from theory.
- An intermediate between the two extremes is to have a separate section for practical investigations within each syllabus section in the student's file, cross-referenced to the relevant theory.

## How is a practical activity organised?

Preparing for practical work needs thought and organisation. The practical work may be an activity that forms part of a lesson, it may comprise an entire lesson or it may be an investigation designed to last for several lessons, but in every case, thorough preparation is a key prerequisite for success.

Practical and investigative work should be integrated into the programme of study. The scheme of work should identify appropriate practical investigative experiences for use at the most suitable time. In designing the scheme of work, you need to do the following:

- Consider the resource implications in terms of equipment and materials in stock.
- Think about the seasonal availability of materials such as organisms and the shelf-life of thermo-sensitive or hygroscopic substances, which is sometimes short.
- Consider the time taken from order to delivery of resources, the potential for damage during dispatch and the cost of materials to be obtained from local, national or international suppliers.
- In centres with a large number of students, you may need to schedule carefully. It may be possible to permit several groups to do the work simultaneously or in quick succession, or it may be essential to re-order the scheme of work for different groups so that scarce resources can be used effectively.
- Take note of national or local health and safety regulations relating to chemicals, electricity, growing micro-organisms, etc. There may also be regulations controlling use of controversial materials such as genetically modified organisms.

Once the scheme of work has been established, the next stage is to consider each practical activity or investigation. In an ideal course, you would go through each of the following stages when developing each practical exercise. In the real world, however, this is not always possible the first time you run a course, which is one of the reasons for producing this booklet. It is better to get going and do some practical work with students than to hold out for perfection before attempting anything. Obviously, all practical work should be subject to careful and rigorous risk assessment, no matter how provisional the rest of the supporting thinking and documentation.

- Decide on the aims of the work – the broad educational goals, in terms of the broad skill areas involved (e.g. planning), and the key topic areas.
- Consider the investigative skills to be developed. You should refer to the syllabus, which in the practical skills section includes learning outcomes relating to practical skill. For example, if the intended practical work is to be a planning exercise, which of the specific skills identified in the learning outcomes will be developed?
- With reference to the topics included, decide on the intended learning outcomes of the practical activity or investigation, again referring to the syllabus. For example, which of the transport learning outcomes will be achieved? In a few cases during the course, the material on which the practical is based may be unfamiliar, in which case there may be no topic-related intended learning outcomes. Thus, A2 contexts may be used for AS practicals, and topic areas not on the syllabus may be used for AS or A2 practicals.



- In addition, it is useful to assess any other context of the practical investigation. For example, is it intended as part of the introduction to a concept, to support a theory or to demonstrate a process?
- Produce a provisional lesson plan, allocating approximate amounts of time for the introduction, student activities and summarising.
- Produce and trial a student worksheet. You can use published procedures or those produced by other teachers, or you can produce your own. As a rule, schedules produced by others need to be modified to suit individual groups of students or the available equipment. It is helpful to ask students or another teacher to read worksheets before they are finalised to identify instructions that are ambiguous or use inaccessible terminology.
- Refine the lesson plan in relation to the number of students for which the investigation is intended (whole class or a small group) and the available equipment (does some have to be shared?) and materials. There are examples of lesson plans and student worksheets in Appendix 2.
- Carry out a detailed and careful risk assessment (see below) before any preparatory practical work is done, and certainly well before students do any of the practical work. You should consider:
  - the likelihood that any foreseeable accident might occur – for example, when pupils are putting glass tube through bungs, they are quite likely to break the tube and push it through their hand;
  - the potential severity of the consequences of any such accident – for example dropping a plastic dropper bottle of  $0.01 \text{ mol dm}^{-3}$  hydrochloric acid onto a desk would cause much less severe eye injuries than the same accident with a glass bottle containing  $5.0 \text{ mol dm}^{-3}$  hydrochloric acid;
  - the measures that can be taken to reduce the severity of the effect of any accident – for example, the teacher or technician preparing bungs with glass tubes before the lesson, or using eye protection such as safety spectacles during all practical work.
- Make an equipment and materials list. This may need to be in sections and should include the following information:
  - materials and apparatus per student or per group (chemicals and glassware);
  - shared equipment per laboratory (water baths, microscopes, pH meters);
  - any chemicals should include concentrations and quantities needed;
  - any equipment should include number required;
  - any hazard associated with specific chemicals or equipment should also be noted and cross-referenced to the risk assessment – sources of information about safety may be found in the syllabus (and are reproduced below);
  - the location of storage areas for equipment and chemicals, which may be cross-referenced to the equipment and materials in the list.
- Set up and maintain a filing system where master copies of the worksheets, lesson plans and equipment lists can be stored. It is helpful to have these organised, or at least indexed, by both their syllabus context and skills developed.
- Once an investigation has been used by a group of students, it should be evaluated in relation to intended outcomes and the lesson plan. It is important to obtain feedback from the students about their perceptions of the work. For example:
  - was the time allocation appropriate;
  - were the outcomes as expected;

- did they enjoy the work;
- did they understand the instructions;
- was the point of the work clear to them?

If necessary, the worksheet and lesson plan should be revised.

## Risk assessment

All practical work should be carried out in accordance with the health and safety legislation of the country in which it is done. You should not attempt any activities that conflict with this legislation.

Hands-on practical work can be carried out safely in schools. However, to ensure that it is safe, you must identify the hazards and reduce any associated risks to insignificant levels by adopting suitable control measures. You should carry out these risk assessments for all the activities involved in running practical science classes, including storage of materials, preparatory work undertaken by the teacher and any technical support staff, and practical activities carried out in the classroom, whether demonstrations by the teacher or practical activities undertaken by the students. Such risk assessments should also be carried out in accordance with the health and safety legislation of the country in which you are working.

Risk assessment involves answering two basic questions:

1. **How likely is it that something will go wrong?** For example, pupils using a double-sided razor blade to cut up carrots are quite likely to cut themselves.
2. **How serious would it be if it did go wrong?** For example, the consequences of a spark from an experiment landing in an open bottle of magnesium powder are likely to be serious, and include spraying burning magnesium all over the laboratory, burning many pupils and setting the laboratory ceiling on fire (this scenario is based on a real accident).

Once you have the answers to these questions, it is possible to plan the practical activity to minimise the risk of an accident occurring and, if it does, to minimise its possible severity. In our first example, this could include cutting up the carrot before giving it to young pupils or providing older pupils with an appropriate sharp knife rather than a razor blade; in the second, it could include bringing only the amount of magnesium powder required for the activity into the laboratory.

The likelihood that something will go wrong depends on who is carrying out the activity and what sort of training and experience they have had. Obviously you would not ask 11-year-old students to heat concentrated sulphuric acid with sodium bromide or to transfer *Bacillus subtilis* cultures from one Petri dish to another, simply because their inexperience and lack of practical skills would make a serious accident all too likely. However, by the time they reach post-16, they should have acquired the skills and maturity to carry such activities out safely.

Decisions need to be made as to whether an activity should only be carried out as a teacher demonstration or whether it could be performed by students. Clearly, some experiments should normally only be done as a teacher demonstration or by older students. Well-motivated and able students may be able to carry out such an experiment at a younger age, but any deviation from the model risk assessment needs to be discussed and a written justification must be prepared beforehand.

There are some activities that are intrinsically dangerous and, if included in the suggested procedure, should always be changed to include safer modes of practice. For example,

there are **no** circumstances under which mouth pipetting is acceptable – pipette fillers of some sort should **always** be used.

Teachers tend to think of eye protection as the main control measure for preventing injury. In fact, personal protective equipment, such as goggles or safety spectacles, is meant to protect from the unexpected. If you expect a problem, more stringent controls are needed. A range of control measures may be adopted, the following being the most common. Use:

- a less hazardous (substitute) chemical;
- as small a quantity as possible;
- as low a concentration as possible;
- a fume cupboard; and
- safety screens (more than one is usually needed, to protect both teacher and students).

The importance of using the lowest possible concentrations is not always appreciated, but the following examples, showing the hazard classification of a range of common solutions, should make the point.

ammonia (aqueous)	irritant if $\geq 3 \text{ mol dm}^{-3}$	corrosive if $\geq 6 \text{ mol dm}^{-3}$
sodium hydroxide	irritant if $\geq 0.05 \text{ mol dm}^{-3}$	corrosive if $\geq 0.5 \text{ mol dm}^{-3}$
hydrochloric acid	irritant if $\geq 2 \text{ mol dm}^{-3}$	corrosive if $\geq 6.5 \text{ mol dm}^{-3}$
nitric acid	irritant if $\geq 0.1 \text{ mol dm}^{-3}$	corrosive if $\geq 0.5 \text{ mol dm}^{-3}$
sulphuric acid	irritant if $\geq 0.5 \text{ mol dm}^{-3}$	corrosive if $\geq 1.5 \text{ mol dm}^{-3}$
barium chloride	harmful if $\geq 0.02 \text{ mol dm}^{-3}$	toxic if $\geq 0.2 \text{ mol dm}^{-3}$ (or if solid)

Reference to the above table shows, therefore, that if sodium hydroxide is in common use, it should be more dilute than  $0.5 \text{ mol dm}^{-3}$ . Using more concentrated solutions requires measures to be taken to reduce the potential risk.

### Material Safety Data Sheets (MSDS)

Your risk analysis should consider the hazards associated with the materials you propose to use. These risks are best assessed by reference to MSDS's appropriate to the chemical(s) in use. These are generally supplied by the chemical manufacturer and supplied with the chemical. If this is not the case then there are many internet sites that have this information freely available. These sheets also provide useful information on the actions to take following an accident, including first aid measures, and should therefore be considered essential for all practical experiments involving chemicals, as part of the risk assessment process.

Your risk assessment should not be restricted simply to the materials, procedures and equipment that will be used, but should have a wider remit that covers the time from when the students enter the room until they leave it.

### Eye protection

Clearly students will need to wear eye protection. Undoubtedly, chemical splash goggles give the best protection but students are often reluctant to wear goggles. Safety spectacles give less protection, but may be adequate if nothing classed as corrosive or toxic is in use.

Practical science can be – and should be – fun. It must also be safe. The two are not incompatible.

Further relevant information on health and safety can be obtained from the following publications:

*Safeguards in the School Laboratory*, 10th edition, ASE, 1996

*Topics in Safety*, 2nd edition, ASE, 1988

*Hazcards*, CLEAPSS, 1998 (or 1995)

*Laboratory Handbook*, CLEAPSS, 1997

*Safety in Science Education*, DfEE, HMSO, 1996

*Hazardous Chemicals Manual*, SSERC2, 1997

## AS skills

### Teaching students to manipulate apparatus

Students gain the necessary skills of manipulating apparatus through becoming familiar with various techniques during the practical part of the course. However, skills do need to be taught and demonstrated. Manipulating some pieces of apparatus is quite complicated and it is sometimes advisable to provide short exercises to build student confidence in using certain techniques. A particular example is the skills needed to perform accurate titrations. In Appendix 2, Experiment 1 provides a simple titration to build these skills. Prior to students performing this particular experiment, you may wish to provide short exercises in using the burette and pipette, depending on their previous experience.

A useful way of showing students the different degrees of precision in volume measurement is to use a pipette and burette to deliver volumes of water into measuring cylinders. This also provides several short exercises to give students confidence in using pipettes and burettes. For example, a 10 cm<sup>3</sup> pipette could be used to check out the accuracy of a 10 cm<sup>3</sup> measuring cylinder. Another experiment may involve running exactly 20 cm<sup>3</sup> of water from a burette into a 25 cm<sup>3</sup> measuring cylinder and a 50 cm<sup>3</sup> measuring cylinder to demonstrate the greater accuracy of a 25 cm<sup>3</sup> measuring cylinder.

Experiment 2 extends the opportunity to perform volumetric analyses, while Experiment 3 also introduces students to the technique of using a volumetric flask to make up solutions accurately.

### Teaching students to make observations and measurements

These skills are fundamental to practical work and many experiments and investigations require students to use both. As experienced scientists, we may forget that students do not automatically acquire these skills. The best way to teach students to make observations and measurements is by getting them to practise using these techniques in the context of their practical work. In this way, students come to understand that the techniques they are learning are not just necessary for examinations, but are important skills, without which chemistry could not progress.

Observational skills involve noting the detail of something. It may be a colour change or the production of bubbles of gas. Even making simple observations, a skill we, as teachers, may take for granted, needs to be developed through opportunities in a practical course.

Making measurements and understanding their accuracy is also something that students need to practise throughout their course. Students need to consider to how many decimal places a particular piece of apparatus can measure and how appropriate such measurements are. For example in Experiment 15, which concerns measuring rates of reaction, students may have access to stop watches that measure to the nearest hundredth of a second, but accuracy to the nearest second is more appropriate. Thus students should be encouraged to consider what number of decimal places to use when recording their data. This does not mean that results should arbitrarily be rounded up or down, as this will affect their reliability.

In the previous section we mentioned the techniques required for titration and suggested short exercises you could ask students to perform prior to doing Experiment 1. These short exercises could also be used to teach students how to make accurate measurements using a burette, measuring cylinder and pipette. Reading the scale with the eye level with the bottom of the meniscus is something you will need to reinforce. Fig. 1.3 in Experiment 1 provides a good illustration of why this is essential.

Burettes should be read to the nearest  $0.05 \text{ cm}^3$ . It is possible to determine whether the bottom of the meniscus is nearer to a graduated mark or nearer to the middle of two  $0.1 \text{ cm}^3$  marks, hence reading to the nearest  $0.05 \text{ cm}^3$ . However, it is not possible to say precisely that a reading is, for example,  $20.01 \text{ cm}^3$  because the closeness of the  $0.1 \text{ cm}^3$  marks does not allow this degree of accuracy. In addition, the smallest drop that a burette can deliver is approximately  $0.05 \text{ cm}^3$ .

The thermometer is another measuring instrument where accuracy depends on the scale. A thermometer calibrated in  $1^\circ\text{C}$  intervals can be read to the nearest  $0.5^\circ\text{C}$ , whereas another calibrated in  $0.2^\circ\text{C}$  intervals can be read to the nearest  $0.1^\circ\text{C}$ . A good experiment for exploring this is Experiment 8 in Appendix 2, where the thermometer we suggest you use is calibrated from  $-5^\circ\text{C}$  to  $+50^\circ\text{C}$ , and the graduations are  $0.2^\circ\text{C}$ . You can ask students why this choice is preferable to a thermometer measuring from  $-10^\circ\text{C}$  to  $+110^\circ\text{C}$  in  $1^\circ\text{C}$  intervals.

Many measurements require a judgement to be made. This is very clear in Experiment 15, where the reaction rate between sodium thiosulphate solution and dilute hydrochloric acid is measured by timing the disappearance of a cross drawn on a piece of paper. The stopwatch is stopped when the student judges that the cross has disappeared. No matter how accurate the stopwatch, the student's judgement will affect the reliability of the data. If you ask different groups what measurements they made at the same temperature, there is likely to be a wide variation. In this case, the measurements should be made by the same individual to make them more reliable. If there is time, experiments should be repeated until they do not show too much variation to ensure reliability. In a titration with a sharp end-point, titres should be within  $0.10 \text{ cm}^3$ .

### Teaching students to record and present data and observations

There is little point in doing experiments if the results are not recorded in a systematic way. This is a skill to which students need to be introduced. Our experience, and probably yours, is that students need to be convinced that they should record results so that they can use them to draw conclusions when the experiment is over. Too often students make unintelligible scribbles, the meaning of which they think they will remember accurately for the next lesson. Getting students into the habit of recording their results is probably something that will require persistence and patience, but it is worth it.

Tables are a very good way to organise results, provided that some thought has gone into their construction, for example thinking about how many columns will be needed. Columns should be correctly labelled, with appropriate headings that describe what the data is and the units used if a measurement is involved. This also makes drawing graphs easier, since column headings can then be transferred onto axes.

In the previous section we discussed the number of decimal places that should be used. In a column of results, all the raw data should be expressed to the same number of decimal places, as this indicates that the accuracy is consistent. This is something that students need to be reminded about, quite frequently, as it is fundamental to experimental work. When data in a column is calculated, then the number of significant figures needs to be considered; this should be appropriate to the degree of accuracy of the apparatus used. This is decided by determining which of the measurements is least accurate and to what number of significant figures it is accurate. The appropriate number of significant figures to be recorded is this number, or one more than this number.

In the very first experiment in Appendix 2, students are introduced to putting their titration results in a table. In Experiments 2 and 3, they are expected to produce similar tables for their data. Check on this as you go round to different students and ensure that their tables of

results are neat. This is important because neatly recording results saves time – it prevents students needlessly having to copy out data, which could result in them copying incorrectly.

An exercise that you may wish to develop is to give students a range of different tables that have errors in them or that are constructed in an inappropriate fashion. Ask them to work in groups and suggest ways in which the tables could be improved.

Graphs are often an effective way of presenting data and demonstrating relationships and trends. Again, getting students into the right habits from the outset will pay dividends for them later. Some of the key features of drawing a graph are:

- having a title that describes what the graph represents;
- labelling the axes and including the correct units;
- plotting the independent variable on the  $x$ -axis and the dependent variable on the  $y$ -axis;
- using a sharp pencil;
- choosing a sensible scale for axes – use most of the graph paper (at least half in both dimensions) but ensure the graph is still convenient to plot;
- where data varies continuously, drawing the line of best fit;
- identifying anomalous results and not giving these undue weight.

You can really emphasise this in the rate experiments suggested in Appendix 1: Experiments 14 to 16.

Many experiments involve presenting qualitative data. This also needs to be accurately recorded in such a way that makes it easy to understand the results. If a particular experiment has several stages, then any changes, or lack of them, should be clearly identified at each stage.

### Teaching students to analyse data and draw conclusions

Drawing conclusions is a skill that involves analysing the results of a practical and stating and explaining what they show.

Some conclusions are drawn from qualitative observations. In Experiment 21, the relative oxidising powers of the halogens are seen through their displacement reactions. The results are then drawn together to show a trend in oxidising power from chlorine to iodine.

Before drawing a conclusion, it may be necessary to do a calculation. It is essential to show the key steps in the working so that a competent scientist can follow the process and check the accuracy. In Experiment 1, titration readings are duplicated to ensure accuracy and to identify anomalous results. This means that an average must be calculated and the working should be shown. If there is an anomalous result, then this should not be included in the calculated average.

Processed results are often shown in graphical form. In Experiment 14 of Appendix 1, gradients can be calculated to give initial rates at time zero. These are then plotted on axes of rate ( $y$ -axis) versus concentration ( $x$ -axis). Explain to students that when calculating gradients, large triangles should be used to give a more accurate calculation.

Graphs are an excellent way of showing trends and relationships. A straight-line graph shows that there is a directly proportional relationship between the dependent and independent variables. A conclusion should always be supported by evidence from the data and in the case of the directly proportional relationship, the graph should be referred to as providing the evidence. Sometimes graphs are used to find unknown values by using co-ordinates or extrapolation. Students need to practise this skill to gain confidence in it.

Students should be encouraged to consider why data is analysed in the way that it is. For example, what is the advantage of drawing a graph over just presenting results in a table?

### Teaching students to evaluate procedures

Evaluation is a skill that students do find difficult to develop. They need to think critically about the reliability of their data and the validity of their conclusions. When developing students' skills in this area, a good place to begin is to consider errors.

There are two types of error that affect results. Random errors cause results to fluctuate around a mean value and data is made more reliable by averaging repeated readings. Systematic errors affect all measurements in the same way, producing lower or higher values than the true result. These cannot be averaged out. Sometimes they are due to the particular experimental procedure that has been adopted. For example, when one person performs a rate experiment it may take time to mix the reagents and start the stop clock. This error can be minimised, or even eliminated, by using two people, one to do the timing and one to mix the reagents. Another source of systematic error may be the measuring device itself. This can be checked by seeing if two different instruments give the same values. In Experiment 8, there will be unavoidable heat losses when trying to assess enthalpy change and this causes a systematic error.

Students should be looking at experiments and assessing the relative importance of errors in measurement, or in making observations, so that they can judge which sources of error are most important. They should be able to express these errors in a standard format. For example, the measurement of volume from a burette may be  $20.00 \text{ cm}^3 \pm 0.05 \text{ cm}^3$ , while that from an electronic balance may be  $\pm 0.01 \text{ g}$ .

Experiment 4 provides a good opportunity to compare values obtained for the formula of magnesium oxide by different groups of students. The loss of magnesium oxide during flare-ups is probably the most significant source of error. If students have only one value, how can they tell how accurate their results and conclusions are?

In evaluating experiments, students should be able to do the following:

- Suggest improvements to the procedures they adopt.
- Compare repeated results to consider their similarity and thus how reliable they are.
- Identify results that are clearly anomalous.
- Identify variables that they need to control. In some experiments, students need to keep variables constant. For example in Experiment 13, 'Determining the value of  $K_c$  for an equilibrium reaction', temperature changes have a significant effect on the results, yet it is very difficult to control temperature variation over a few days without the use of a constant temperature water bath.
- Estimate uncertainty in measurement.
- Distinguish between random and systematic errors.

The above points need to be discussed at the end of experiments. Get students to suggest a checklist they could use to evaluate experiments that incorporates these ideas. Also point out to them that perfect experiments make for poor evaluation.



## Designing a practical course for the AS year

We have already expounded the essential place of practical work in any chemistry course. Students develop their practical skills through being taught how to use them and then practising them.

The course we have suggested in Appendix 1 is simply that, a suggestion. There may be other experiments that you think work better or demonstrate a concept more effectively. In building our practical course we have gone through the theoretical and practical learning outcomes that need to be achieved and linked them to the syllabus. We have tried to provide a variety of approaches and to suggest practicals, where possible, with a 'real world' context. You will notice that certain skills are practised in several different experiments. For example, titration work occurs in three experiments at the outset of the course to build the necessary skills and these are reinforced in Experiments 13 and 23.

It is very tempting to drill students in the skills they need by endlessly practising past examination papers, but this provides an arid experience for them and does not relate the concepts they meet in theory to observations made through experiment. Yes, there is a place for doing past-paper work, but this should be limited to the very end of the course to reinforce the skills developed from all the varied practical work we recommend that students should carry out.

Of the 30 experiments in Appendix 1, 10 are fully worked up in Appendix 2 with Student Sheets and Teachers' Notes. The other 20 are presented in outline, in the hope that you will develop them to suit your own students and ways of working. Sometimes local circumstances mean that you cannot perform some of the experiments we suggest. In these instances, it may be possible to substitute other practicals that cover the same learning outcomes. There are several good practical textbooks that can support your course. We have featured some experiments from the Royal Society of Chemistry's books, *Classic Chemistry Experiments: One hundred tried and tested experiments* and *Classic Chemistry Demonstrations: One hundred tried and tested experiments*. What we hope comes across is how important we feel a well-constructed AS chemistry course is in developing a love of the subject and in furnishing students with the practical skills they will need to be successful both in the examination and in future practical work.

### Sources

Many of the experiments listed in Appendix 1 can be found in the following books:

*Classic Chemistry Experiments: One hundred tried and tested experiments*, compiled by Kevin Hutchings, published by the Royal Society of Chemistry, [www.rsc.org](http://www.rsc.org) (ISBN 0 85404 9193)

*Classic Chemistry Demonstrations: One hundred tried and tested experiments*, compiled by Ted Lister, published by the Royal Society of Chemistry, [www.rsc.org](http://www.rsc.org) (ISBN 1 870 343 38 7)

## Appendix 1

Syllabus section	Skills/Learning Outcomes	Notes	Sources
1g, 1h	<b>1. Making salt – an introduction to some basic techniques</b>		
	<ul style="list-style-type: none"> <li>Acquire skills in manipulating apparatus</li> <li>Acquire skills in reading a burette and using a pipette</li> <li>Revise use of Bunsen burner</li> <li>Introduction to titration</li> <li>Use and understand molecular and ionic equations</li> <li>Use the mole concept</li> </ul>	<p>Approximately <math>0.1 \text{ mol dm}^{-3}</math> solutions of hydrochloric acid (<b>Corrosive</b>) and sodium hydroxide (<b>Corrosive</b>) are used in a titration experiment to produce sodium chloride solution. The water is then evaporated to concentrate the salt solution and produce sodium chloride crystals.</p> <p><b>Timing:</b> 1.5 hours if salt solution is to be evaporated</p>	<b>Appendix 2</b>
1h	<b>2. Which is the best indigestion tablet?</b>		
	<ul style="list-style-type: none"> <li>Acquire skills in manipulating apparatus</li> <li>Acquire skills in reading a burette and using a pipette</li> <li>Make decisions relating to measurements and observations</li> <li>Draw conclusions</li> <li>Identify sources of error and suggest improvements</li> </ul>	<p>This experiment reinforces the techniques of titration and can be used to give students an opportunity to develop some of the skills they will need for the Practical Assessment.</p> <p>In addition to the apparatus listed in Practical 1, you will need different brands of indigestion tablet, mortars and pestles, <math>0.1 \text{ mol dm}^{-3} \text{ HCl}</math> and methyl orange indicator.</p> <p>If the cost of each packet of tablets is known, this experiment could be used to determine which tablet represents best value. If pestles and mortars are not available, indigestion powders can be made up in advance using <math>\text{NaHCO}_3(\text{s})</math> and <math>\text{NaCl}(\text{s})</math>.</p> <p><b>Timing:</b> 1.5 hours to plan, carry out the investigation, process results and draw conclusions. This could include homework time</p>	<i>Classic Chemistry Experiments</i> , The Royal Society of Chemistry – Experiment 60

## Appendix 1

Syllabus section	Skills/Learning Outcomes	Notes	Sources
1h	<b>3. Determining the mass of iron in iron tablets</b>		
	<ul style="list-style-type: none"> <li>Perform a titration involving potassium manganate(VII)</li> <li>Develop skills in reading a burette and using a pipette</li> <li>Record results appropriately</li> <li>Use and understand an ionic equation</li> <li>Use the mole concept to perform calculations</li> </ul>	<p>This volumetric analysis is intended to further develop skills of accurate titration. It introduces a potassium manganate(VII) (<b>Oxidising, Harmful, Dangerous to the environment</b>) titration in an interesting context.</p> <p><b>Timing:</b> One lesson for the practical and another lesson to explain the processing of the results. Approximately 1.5 hours</p>	<b>Appendix 2</b>
1f, 1h	<b>4. Finding the formula of magnesium in magnesium oxide</b>		
	<ul style="list-style-type: none"> <li>Acquire skills in manipulating apparatus</li> <li>Acquire skills in accurate measurement</li> <li>Calculate the empirical formula of magnesium oxide from reacting masses</li> </ul>	<p>This is a simple experiment to perform but there is much scope for experimental error. Do not worry about this, as there is a great deal of learning to be gained.</p> <p>Weigh a crucible and lid to at least two decimal places. Clean about 15 cm of magnesium with an emery cloth. Coil it round a pencil and place the loose coil in the crucible, then weigh this together with the lid. Place on a pipe-clay triangle on a tripod and heat. Lift the lid very slightly to let more oxygen in but immediately replace it to prevent magnesium oxide escaping. Do this until the magnesium no longer flares up. Remove the lid and heat strongly for 5 minutes. Allow to cool and re-weigh. The increase in mass of the magnesium is due to the oxygen that combines with it.</p> <p><b>Note:</b> A typical porcelain crucible will itself react with the magnesium, leaving black 'stains'. This can be used in the discussion of results. Magnesium nitride (<math>Mg_2N_3</math>) may also be formed.</p> <p><b>Timing:</b> 1 hour, which includes discussing the calculation</p>	<i>Classic Chemistry Experiments</i> , The Royal Society of Chemistry – Experiment 67

## Appendix 1

Syllabus section	Skills/Learning Outcomes	Notes	Sources
1g, 1h, 4c	<b>5. What is the volume of 1 mole of hydrogen gas?</b>		
	<ul style="list-style-type: none"> <li>Further develop skills in manipulating apparatus and accurate measurement</li> <li>Use the mole concept</li> <li>Calculate the molar volume at room temperature and pressure</li> </ul>	<p>This experiment allows students to perform a procedure to calculate the molar volume. It gives practice in calculations involving the mole concept.</p> <p><b>Timing:</b> 1 hour, which includes discussing the calculation</p>	<p><b>Appendix 2</b> Also in <i>Classic Chemistry Experiments</i>, The Royal Society of Chemistry – Experiment 68</p>
4c	<b>6. Determining the relative molecular masses of a gas</b>		
	<ul style="list-style-type: none"> <li>Use the general gas equation <math>PV=nRT</math> to determine <math>M_r</math></li> </ul>	<p>This experiment provides a simple, quick method for finding the relative molecular mass of butane. You will need a can of butane, used for re-filling cigarette lighters. Weigh the can before the experiment and then attach a length of flexible tubing to enable 1 dm<sup>3</sup> of the gas to be collected over water. Then dry and weigh the can again. Another possibility is to use a cigarette lighter, in which case you will not need the delivery tube – simply hold the lighter in the water trough below the measuring cylinder. This is slower and it is better to collect 250 cm<sup>3</sup> gas – which still gives a mass loss of approximately 0.4 g. <math>PV=nRT</math> can be used to calculate the number of moles in the known mass of gas. If you cannot measure the pressure accurately, it is worth making an educated guess.</p> <p><b>Timing:</b> 30 minutes for the practical</p>	<p><i>Classic Chemistry Demonstrations</i>, The Royal Society of Chemistry – Experiment 7</p>

## Appendix 1

Syllabus section	Skills/Learning Outcomes	Notes	Sources
4e	<b>7. The effect of heat on different substances</b>		
	<ul style="list-style-type: none"> <li>Relationship between lattice structure and melting points</li> <li>Sodium chloride and magnesium oxide are ionic lattices</li> <li>Silicon(IV) oxide and graphite are giant molecular</li> <li>Iodine and sulphur are simple molecular</li> <li>Copper is a metallic lattice</li> </ul>	<p>This is a very simple set of experiments. Heating one or two crystals of iodine, placed in a conical flask, should be an opening demonstration as iodine is harmful and will stain skin and clothing. The iodine sublimes to give a purple vapour that turns back to crystals on cooling. Students can perform the other experiments, noting down their observations. NaCl, MgO, graphite powder and sand (which is mainly SiO<sub>2</sub>) can be heated in hard glass test tubes. A small piece of copper can be heated with tongs and a small quantity of sulphur can be heated on a tin lid or bottle top.</p> <p><b>Timing:</b> 30 minutes. This practical could be arranged as a circus</p>	Most A level practical textbooks will cover something similar
5b, 5c, 1h	<b>8. Measuring the enthalpy changes of exothermic and endothermic reactions</b>		
	<ul style="list-style-type: none"> <li>Further develop skills in manipulating apparatus and accurate measurement of temperature</li> <li>Know that some chemical reactions are accompanied by energy changes in the form of heat energy</li> <li>Know that energy changes can be exothermic (<math>\Delta H</math>, negative) or endothermic (<math>\Delta H</math>, positive)</li> <li>Calculate enthalpy changes from your experimental results using enthalpy change = <math>mc\Delta T</math></li> </ul>	<p>This is a good experiment for introducing some of the main concepts of chemical energetics. Students do two experiments using polystyrene cups as calorimeters. Enthalpy change = <math>mc\Delta T</math> is used to calculate the enthalpy changes of two reactions.</p> <p><b>Timing:</b> 1 hour that includes discussing the calculation and a homework for completion</p>	<b>Appendix 2</b> Most A level practical textbooks will cover something similar

## Appendix 1

Syllabus section	Skills/Learning Outcomes	Notes	Sources
5b, 5c, 1h	<b>9. Measuring the enthalpy change of neutralisation</b>		
	<ul style="list-style-type: none"> <li>Determine the enthalpy change of neutralisation through experiment and calculation</li> <li>Explore the reason for similar values obtained for different neutralisation reactions per mole of water formed</li> </ul>	<p>25 cm<sup>3</sup> of 1 mol dm<sup>-3</sup> HCl is used to neutralise solutions of 25 cm<sup>3</sup> of 1 mol dm<sup>-3</sup> NaOH (<b>Corrosive</b>) and KOH (<b>Corrosive</b>) separately, using the apparatus described in Experiment 8 (Appendix 2). Following the calculation, similar values for enthalpy changes should be obtained (actual value is approximately 58 kJ mol<sup>-1</sup>). As an extension, 50 cm<sup>3</sup> of 1 mol dm<sup>-3</sup> H<sub>2</sub>SO<sub>4</sub> (<b>Corrosive</b>) could be used. This would give double the value of the above neutralisation reactions as there are 2 moles of H<sup>+</sup> for every mole of H<sub>2</sub>SO<sub>4</sub>.</p> <p><b>Timing:</b> 1 hour</p>	Most A level practical textbooks will cover something similar
6b	<b>10. Experiments to show which ions move to the anode and cathode</b>		
	<ul style="list-style-type: none"> <li>Greater awareness of the properties of ions as charged particles</li> <li>Introduce the terms anode and cathode</li> <li>Explain what is happening in the electrolysis of sodium chloride solution</li> </ul>	<p>This is a useful introduction to electrochemistry. Cut filter paper to fit a microscope slide or watch glass. Draw a faint pencil line in the middle of the paper. Moisten it with tap water and place a crystal of potassium manganate(VII) (<b>Oxidising, Harmful, Dangerous to the environment</b>) on the pencil line. Connect two wires to a 6 V DC supply and attach the crocodile clips at the end of the wires on either side of the pencil line, holding the filter paper to the glass. After 10 minutes, the purple-coloured band due to the MnO<sub>4</sub><sup>-</sup> ion moves to the anode. A similar experiment can now be done with a saturated solution of sodium chloride. This time use universal indicator paper soaked with the salt solution. The paper goes blue at the anode (due to OH<sup>-</sup>) and red at the cathode (due to H<sup>+</sup>).</p> <p><b>Timing:</b> 30 minutes</p>	A similar sort of experiment is found in <i>Classic Chemistry Experiments</i> , The Royal Society of Chemistry – Experiment 15

## Appendix 1

Syllabus section	Skills/Learning Outcomes	Notes	Sources
6b	<b>11. Electrolysing sodium chloride and copper(II) sulphate solution</b>		
	<ul style="list-style-type: none"> <li>Understand the electrode reactions occurring when brine (concentrated sodium chloride solution) and aqueous copper(II) sulphate are electrolysed</li> <li>Understand how the experiments relate to the industrial processes of the diaphragm cell and the electrolytic purification of copper</li> </ul>	<p>If you have access to low voltage DC sources, this is a worthwhile experiment for students to perform or for you to demonstrate. Use graphite electrodes to electrolyse a concentrated solution of sodium chloride and a copper(II) sulphate solution (<b>Harmful, Dangerous to the environment</b>). Also electrolyse Copper(II) sulphate using copper electrodes. The different gaseous products can be tested.</p> <p><b>Timing:</b> 40 minutes</p>	<p><i>Classic Chemistry Experiments</i>, The Royal Society of Chemistry – Experiments 82 and 92 Most A level practical textbooks will also include this experiment</p>
7a, 7b	<b>12. Introducing equilibria through two demonstrations</b>		
	<ul style="list-style-type: none"> <li>Understand what is meant by a reversible reaction and a dynamic equilibrium</li> <li>Introduce and use Le Chatelier's Principle</li> <li>Observe the effects of changes of concentration and temperature on the equilibrium position</li> </ul>	<p>Two experiments are suggested:</p> <ol style="list-style-type: none"> <li>The equilibrium between <math>\text{Co}(\text{H}_2\text{O})_6^{2+}</math> and <math>\text{CoCl}_4^{2-}</math></li> <li>The equilibrium between bismuth oxide chloride and bismuth trichloride</li> </ol> <p>Conditions are altered and are found to be as predicted by Le Chatelier's Principle.</p> <p><b>Timing:</b> Each demonstration takes about 5 minutes but securing the learning outcomes from the demonstrations will require 1 hour</p>	<p><b>Appendix 2</b> <i>Classic Chemistry Experiments</i>, The Royal Society of Chemistry – Experiments 8 and 87</p>
7d, 7e, 7f	<b>13. Determining the value of <math>K_c</math> for an equilibrium reaction</b>		
	<ul style="list-style-type: none"> <li>Deduce an expression for the equilibrium constant, <math>K_c</math></li> <li>Calculate a value for <math>K_c</math> from the concentrations of substances at equilibrium</li> <li>Further develop skills in titration techniques</li> </ul>	<p>This experiment allows students to use skills they have gained from volumetric analysis to measure equilibrium concentrations for</p> $\text{CH}_3\text{COOH} + \text{C}_2\text{H}_5\text{OH} \rightleftharpoons \text{CH}_3\text{COOC}_2\text{H}_5 + \text{H}_2\text{O}$ <p>They can then determine a value for the equilibrium constant.</p> <p><b>Timing:</b> 20 minutes to set up the equilibrium mixtures, which are left for a week, and 1 hour to analyse them</p>	<p><b>Appendix 2</b></p>

## Appendix 1

Syllabus section	Skills/Learning Outcomes	Notes	Sources
8a, 8b	<b>14. The effect of concentration on the rate of a chemical reaction</b>		
	<ul style="list-style-type: none"> <li>Explain and use the term <i>rate of reaction</i></li> <li>Follow the rate of reaction of calcium carbonate and hydrochloric acid using loss of mass of carbon dioxide</li> <li>Measure the effect of different concentrations on the reaction</li> <li>Explain the results obtained in terms of collisions</li> <li>Determine the gradient of a straight line graph</li> <li>Identify the most significant errors in this experiment</li> </ul>	<p>Measuring the rate of reaction using marble chips and dilute hydrochloric acid is a really good introduction to reaction kinetics. The rate can be followed using a top balance, weighing to 0.01 g. Weigh out about 10 g of large marble chips into a conical flask. Quickly add 20 cm<sup>3</sup> of 1 mol dm<sup>-3</sup> hydrochloric acid (<b>Corrosive</b>) and record the mass loss every 15 seconds. From this experiment, a rate curve can be drawn by plotting mass of carbon dioxide lost against time. The experiment can be repeated using other concentrations and these rate curves plotted on the same sheet of graph paper. The gradients of the graphs at time zero can be calculated. These are usually straight line graphs for the first 30 seconds at least. A graph of concentration against time can then be plotted, giving a straight line. This shows that for this reaction a straight line should be obtained.</p> <p><b>Timing:</b> 1 to 2 hours</p>	Most A level practical texts will have some reference to this or a similar experiment
8c, 8d	<b>15. The effect of temperature on reaction rate</b>		
	<ul style="list-style-type: none"> <li>Measure the effect of temperature on a reaction rate</li> <li>Represent results graphically and draw conclusions</li> <li>Explain, in terms of the collision theory, why temperature change affects the reaction rate</li> </ul>	<p>This experiment investigates the effect of temperature on the rate of reaction between sodium thiosulphate and dilute hydrochloric acid.</p> <p><b>Timing:</b> 1 to 1.5 hours</p>	<b>Appendix 2</b> <i>Classic Chemistry Experiments</i> , The Royal Society of Chemistry – Experiment 64



## Appendix 1

Syllabus section	Skills/Learning Outcomes	Notes	Sources
8e	<b>16. Effect of catalysts on the reaction rate</b>		
	<ul style="list-style-type: none"> <li>Catalysts alter the reaction rate</li> <li>Catalysts are unchanged chemically at the end of the reaction</li> <li>Catalysts work by providing a different mechanism for the reaction</li> </ul>	<p>This demonstration is an effective way to introduce the role of catalysts in speeding up reactions. It shows clearly that catalysts do take part in the reaction and are unchanged chemically at the end.</p> <p>Hydrogen peroxide oxidises potassium sodium tartrate (Rochelle salt) to carbon dioxide. The reaction is slow. Adding cobalt(II) chloride (<b>Toxic, Dangerous to the environment</b>) causes the reaction to froth. The colour of the cobalt(II) chloride changes from pink to green to pink, showing that the reaction proceeds by an alternative mechanism.</p> <p><b>Timing:</b> 5 minutes for the demonstration</p>	<p><i>Classic Chemistry Demonstrations</i>, The Royal Society of Chemistry – Demonstration 1</p>
9.1e, 9.1g	<b>17. The reaction of oxygen with some elements in the third period</b>		
	<ul style="list-style-type: none"> <li>Describe the reactions of third period elements with oxygen</li> </ul>	<p>This demonstration examines the reactions of sodium (<b>Corrosive, Highly flammable</b>), magnesium, (<b>Highly Flammable</b>) aluminium, phosphorus (red) (<b>Highly Flammable, Dangerous to the environment</b>) and sulphur. Fill gas jars or boiling tubes with oxygen. Use a combustion spoon to heat very small samples of the elements. Then plunge these into the oxygen. After cooling, add water and test the pH of resulting solutions using universal indicator.</p> <p>Oxygen can be prepared using hydrogen peroxide (<b>Caustic</b>) and manganese(IV) oxide (<b>Harmful</b>) and collecting the gas over water.</p> <p><b>Timing:</b> 30 minutes for the demonstration</p>	<p>Some A level practical texts will have reference to this or a similar experiment</p>

## Appendix 1

Syllabus section	Skills/Learning Outcomes	Notes	Sources
9.1e	<p><b>18. The reaction of sodium and magnesium with water</b></p> <ul style="list-style-type: none"> <li>Describe the reaction of sodium and magnesium with water</li> </ul>	<p>You should do these experiments as demonstrations. Place a very small piece of sodium (<b>Corrosive, Highly Flammable</b>), the size of a rice grain, in a glass trough that is a third filled with water. Cover the trough with a perspex sheet. Test the resulting solution with universal indicator. In a second experiment, trap the sodium on a piece of floating filter paper in the trough. This time the hydrogen produced catches fire. You can show the reaction of magnesium with cold water by trapping some pieces of cleaned magnesium under water in an upturned funnel feeding into a boiling tube full of water. Leave this set up for a week, which will produce 2 or 3 cm<sup>3</sup> of hydrogen.</p> <p>Show the reaction of magnesium with steam by soaking mineral wool with water at the bottom of a test tube. Then push a coil of magnesium into the centre of the tube. Attach a delivery tube and strongly heat the magnesium. The resulting gas, collected over water, is hydrogen, which can be tested with a lighted spill.</p> <p><b>Timing:</b> 30 minutes</p>	<p><i>Classic Chemistry Demonstrations</i>, The Royal Society of Chemistry – Demonstrations 72 and 75</p>

## Appendix 1

Syllabus section	Skills/Learning Outcomes	Notes	Sources
9.1e	<p><b>19. Reaction of sodium with chlorine</b></p> <ul style="list-style-type: none"> <li>Describe the reaction of sodium with chlorine</li> </ul>	<p>If you have access to a fume cupboard, this is a useful demonstration to show the formation of sodium chloride from its elements. Chlorine gas (<b>Toxic, Irritant</b>) can be generated from solid potassium manganate(VII) (<b>Oxidising, Harmful, Dangerous to the environment</b>), covered with water, onto which some concentrated hydrochloric acid (<b>Corrosive</b>) is added from a tap funnel in a typical gas generation apparatus. A gas jar is filled by downward displacement of air. Heat a very small piece of sodium (<b>Corrosive, Highly Flammable</b>) (the size of a rice grain) on a combustion spoon and plunge it into the gas jar of chlorine. Clouds of white smoke show that sodium chloride has formed.</p> <p><b>Timing:</b> 15 minutes</p>	<p><i>Classic Chemistry Demonstrations</i>, The Royal Society of Chemistry – Demonstration 72</p>

## Appendix 1

Syllabus section	Skills/Learning Outcomes	Notes	Sources
9.2a, 9.2b, 9.2c	<p><b>20. Group II practical work</b></p> <ul style="list-style-type: none"> <li>Describe the reactions of the elements with oxygen and water</li> <li>Describe the behaviour of the oxides with water</li> <li>Describe the thermal decomposition of the nitrates and carbonates</li> </ul>	<p>Remind students of the reaction of magnesium with oxygen and water/steam (Experiments 17 and 18).</p> <p><b>Experiment 1.</b> Students can perform an experiment with a small calcium (<b>Highly Flammable</b>) granule in a large beaker of water and devise a method for collecting and testing the hydrogen gas produced.</p> <p><b>Experiment 2.</b> Heat a lump of limestone, or marble chip, suspended from a tripod by nichrome wire, for 15 minutes. Allow to cool on a watch glass. Add one drop of cold water to the previously heated section using a thermometer and note the exothermic reaction. Add more water, drop by drop, from a dropping pipette until no further reaction occurs. Test the pH.</p> <p><b>Experiment 3.</b> Warm a little solid magnesium oxide with water, filter and test the pH.</p> <p><b>Experiment 4.</b> Investigate the relative stabilities to heat of magnesium carbonate, calcium carbonate and strontium carbonate. Test for carbon dioxide.</p> <p><b>Experiment 5.</b> Investigate the relative stabilities of the nitrates of magnesium, calcium and strontium – this must be carried out <b>in a fume cupboard</b> as one of the potential products is <b>poisonous</b>.</p> <p>In all cases, get students to write up equations for the reactions they observe.</p> <p><b>Timing:</b> 1 hour</p>	<p>Many practical texts contain references to these activities</p>

## Appendix 1

Syllabus section	Skills/Learning Outcomes	Notes	Sources
9.4f, 6a	<b>21. Some redox reactions of halogens and halides</b>		
	<ul style="list-style-type: none"> <li>Describe the relative reactivity of the elements as oxidising agents</li> <li>Describe and explain the reactions of halide ions with concentrated sulphuric acid</li> <li>Describe and explain redox processes in terms of electron transfer and/or changes of oxidation number</li> </ul>	<p>Students perform two experiments. The first looks at the displacement reactions of the halogens and the second involves the reactions of the halogens with concentrated sulphuric acid.</p> <p><b>Timing:</b> This depends on the approach taken. The actual experimental work takes 30 minutes for each experiment</p>	<p><b>Appendix 2</b>  <i>Classic Chemistry Experiments</i>, The Royal Society of Chemistry – Experiment 19 for the first experiment. Some practical texts contain references to these activities</p>
9.4f and Practical Assessment	<b>22. Reactions of the aqueous halide ions – testing for halides</b>		
	<ul style="list-style-type: none"> <li>Describe and explain the reactions of halide ions with aqueous silver ions followed by aqueous ammonia</li> <li>Have performed the test for silver halides detailed in the Practical Assessment</li> </ul>	<p>These test-tube experiments give qualitative tests for halide ions.</p> <p><b>Experiment 1.</b> Add five drops of silver nitrate solution (<b>Corrosive, Dangerous to the environment</b>) separately to solutions of sodium chloride, sodium bromide and sodium iodide. Note the appearance of the precipitates. Now add fairly concentrated ammonia solution (about 8 mol dm<sup>-3</sup>) (<b>Corrosive, Dangerous to the environment</b>). Note what happens to each precipitate.</p> <p><b>Experiment 2.</b> Repeat Experiment 1 to obtain a second set of silver halide precipitates. This time leave them to stand in the light and note their appearance.</p> <p><b>Experiment 3.</b> Add five drops of the three halide solutions used in Experiment 1 separately to lead nitrate solution (<b>Toxic, Dangerous to the environment</b>). Note the colours of the precipitates.</p> <p><b>Timing:</b> 45 minutes</p>	<p><i>Classic Chemistry Experiments</i>, The Royal Society of Chemistry – Experiment 89</p>

## Appendix 1

Syllabus section	Skills/Learning Outcomes	Notes	Sources
6a, 1h and Practical Assessment	<b>23. Reaction of iodine with sodium thiosulphate</b>		
	<ul style="list-style-type: none"> <li>Carry out a titration using iodine and sodium thiosulphate</li> <li>Use the results gained to verify the balanced equation for the reaction</li> <li>Work out the oxidation numbers of sulphur in the sodium compounds used and produced in the reaction</li> </ul>	<p>This is a good place to introduce this titration. In this experiment, 10 cm<sup>3</sup> samples of 0.010 mol dm<sup>-3</sup> iodine solution are titrated with 0.010 mol dm<sup>-3</sup> sodium thiosulphate solution, which is delivered from a burette. The end point can be made clearer by adding starch solution when the iodine is a pale straw colour.</p> <p>Students could be asked to see if their results are consistent with the equation for the reaction</p> $2\text{Na}_2\text{S}_2\text{O}_3(\text{aq}) + \text{I}_2(\text{aq}) \rightarrow 2\text{NaI}(\text{aq}) + \text{Na}_2\text{S}_4\text{O}_6(\text{aq})$ <p>It is also a useful exercise to ask students to work out the oxidation numbers of sulphur in the sodium compounds in the equation.</p> <p><b>Timing:</b> 1 hour</p>	<p>Most A level practical texts will contain reference to this volumetric analysis</p>
10.2a, 10.2b, 10.2c, 10.2h	<b>24. Experimenting with alkanes</b>		
	<ul style="list-style-type: none"> <li>Awareness of unreactivity of alkanes</li> <li>Combustion reaction of alkanes</li> <li>Substitution reactions of bromine</li> </ul>	<p>This is very useful as an introduction to organic compounds and it is worth spending time going through the safety aspects, such as what the various hazard-warning symbols mean. Small samples of hexane (<b>Highly Flammable, Harmful, Dangerous to the environment</b>) are used.</p> <p><b>Experiment 1.</b> Dip a combustion spoon into 2 cm<sup>3</sup> hexane in a boiling tube and stopper the tube. Burn this in a Bunsen flame, well away from the stoppered boiling tube.</p> <p><b>Experiments 2 to 6.</b> These investigate the reaction of hexane with (i) bromine water (<b>Highly Toxic, Corrosive, Dangerous to the environment</b>) in the dark (ii) bromine water in sunlight (iii) dilute acidified aqueous potassium manganate(VII) (<b>Oxidising, Harmful, Dangerous to the environment</b>) (iv) two drops of concentrated sulphuric acid (<b>Corrosive</b>) (v) 1 cm<sup>3</sup> dilute potassium hydroxide (<b>Corrosive</b>).</p> <p><b>Timing:</b> 45 minutes</p>	<p>Many A level practical books contain references to these experiments</p>

## Appendix 1

Syllabus section	Skills/Learning Outcomes	Notes	Sources
10.2g	<b>25. Cracking hydrocarbons</b>		
	<ul style="list-style-type: none"> <li>Understand the importance of cracking large hydrocarbon molecules to produce more useful alkanes and alkenes of smaller <math>M_r</math></li> <li>Have continued to develop manipulative and observational skills</li> </ul>	<p>In this experiment, the molecules to be cracked are vaporised over a heated catalyst. The gas produced is collected over water. The experiment is a good test of manipulation and observation.</p> <p><b>Timing:</b> 1 hour</p>	<p><b>Appendix 2</b></p> <p><i>Classic Chemistry Experiments</i>, The Royal Society of Chemistry – Experiment 96</p>
10.2d	<b>26. Experimenting with alkenes</b>		
	<ul style="list-style-type: none"> <li>Combustion reaction</li> <li>Addition of halogens</li> <li>Oxidation by cold, dilute manganate(VII) to form the diol</li> </ul>	<p>Cyclohexene (<b>Highly Flammable, Harmful, Dangerous to the environment</b>) is a convenient alkene to use. Experiments similar to the ones carried out with alkanes in Experiment 24 can be performed, omitting the experiment with potassium hydroxide solution.</p> <p>If desired, the potassium manganate(VII) can be made alkaline using aqueous sodium carbonate. In this case, the diol is still formed but a green coloration followed by a brown precipitate will be seen.</p> <p><b>Timing:</b> 45 minutes</p>	<p>Many A level practical books contain references to these experiments</p>

## Appendix 1

Syllabus section	Skills/Learning Outcomes	Notes	Sources
10.3a, 10.3b, 10.3c	<p><b>27. Some reactions of the halogenoalkanes</b></p> <ul style="list-style-type: none"> <li>Understand that the rate of hydrolysis depends on the strength of the C-Hal bond</li> <li>Understand that the rate of hydrolysis also depends on whether the halogenoalkane is primary, secondary or tertiary</li> <li>Describe the mechanism of nucleophilic substitution as S<sub>N</sub>1 or S<sub>N</sub>2</li> </ul>	<p>These experiments are designed to show the different rates of hydrolysis caused by different halogen atoms and different carbon structures. A further experiment shows that alcoholic alkali causes elimination.</p> <p><b>Experiment 1.</b> Add three drops each of 1-chlorobutane, (<b>Highly Flammable</b>) 1-bromobutane (<b>Irritant, Highly Flammable, Dangerous to the Environment</b>) and 1-iodobutane (<b>Harmful</b>) to 1 cm<sup>3</sup> ethanol (<b>Highly Flammable</b>) in three test tubes. Then react the solutions with 0.02 mol dm<sup>-3</sup> aqueous silver nitrate. Immediately put the test tubes in hot water. Note the rate of appearance of silver halide precipitates.</p> <p><b>Experiment 2.</b> Repeat the method used in Experiment 1, only this time change the carbon skeleton by using three drops each of 1-chlorobutane (primary), 2-chlorobutane (secondary) and 2-chloro-2-methylpropane (<b>Highly Flammable</b>) (tertiary). Note the rate of appearance of silver chloride precipitate. <b>These three halogenoalkanes are highly flammable.</b></p> <p><b>Experiment 3.</b> Show elimination by using 2 cm<sup>3</sup> 20% potassium hydroxide (<b>Corrosive</b>) in ethanol (<b>Highly Flammable</b>) soaked into mineral wool using the apparatus in Experiment 25 (without the aluminium oxide). Ethene gas is collected which can be tested using dilute (pale yellow) bromine water.</p> <p><b>Timing:</b> 1 hour</p>	<p>Many A level practical texts will contain references to these experiments</p>



## Appendix 1

Syllabus section	Skills/Learning Outcomes	Notes	Sources
10.4a, 10.4b	<b>28. Some reactions of alcohols</b>		
	<ul style="list-style-type: none"> <li>Combustion reaction of alcohols</li> <li>Reaction of alcohols with sodium</li> <li>Oxidation of ethanol to ethanal and ethanoic acid</li> <li>Dehydration of alcohols to alkenes</li> <li>Reaction of alcohols with carboxylic acids to form esters</li> </ul>	<p>These experiments introduce students to some reactions of the alcohol functional group.</p> <p><b>Timing:</b> At least 1 hour. This is likely to be spread over two 1-hour practical sessions</p>	<p><b>Appendix 2</b> <i>Classic Chemistry Experiments</i>, The Royal Society of Chemistry – Experiment 79 for Experiments 1 and 3 Most A level practical texts</p>
10.5c, 10.5d	<b>29. Testing for, and deducing the nature of, carbonyl compounds</b>		
	<ul style="list-style-type: none"> <li>Describe the use of 2,4-dinitrophenylhydrazine (2,4-DNPH) to detect the presence of carbonyl compounds</li> <li>Deduce the nature of an unknown carbonyl compound using Fehling's and Tollen's reagents</li> </ul>	<p><b>Experiment 1.</b> Test 3 drops of propanone (<b>Highly Flammable</b>) and 3 drops of propanal (<b>Highly Flammable Harmful</b>) separately with 5 cm<sup>3</sup> 2,4-DNPH (<b>Corrosive, Toxic and Highly Flammable</b>).</p> <p><b>Experiment 2.</b> Test 10 drops of propanone and 10 drops propanal separately with 3 cm<sup>3</sup> Fehling's solution (<b>Corrosive and Toxic</b>).</p> <p><b>Experiment 3.</b> Test 10 drops of the aldehyde and ketone with 3 cm<sup>3</sup> freshly prepared Tollen's reagent.</p> <p><b>Timing:</b> 45 minutes</p>	<p>Many A level practical books provide information about how to make up Tollen's solution and Fehling's solution</p>
10.6b	<b>30. Some reactions of ethanoic acid to form salts</b>		
	<ul style="list-style-type: none"> <li>Describe the reactions of carboxylic acids in the formation of salts</li> </ul>	<p>Show the reactions of the weak acid, ethanoic acid (<b>Corrosive</b>) (0.05 mol dm<sup>-3</sup>). Use universal indicator paper to show neutralisation with</p> <p>(i) sodium carbonate solution (0.4 mol dm<sup>-3</sup>) (ii) sodium hydroxide solution (0.4 mol dm<sup>-3</sup>) (<b>Corrosive</b>).</p> <p>Add a small piece of magnesium ribbon (<b>Highly Flammable</b>) to 2 cm<sup>3</sup> of the above acid and test the gas evolved for hydrogen.</p> <p><b>Timing:</b> 30 minutes</p>	<p><i>Classic Chemistry Experiments</i>, The Royal Society of Chemistry – Experiment 78</p>

## Appendix 2

## 1. Making salt – an introduction to some basic techniques – Student Sheet

This practical is intended to help you become confident in some of the skills you may have used in your previous chemistry course. It will also help you revise some concepts and learn new ones.

### Intended lesson outcomes

By the end of this practical you should be able to:

- manipulate apparatus successfully;
- read a burette and use a pipette;
- use a Bunsen burner;
- carry out a titration experiment;
- record your titration results in the tables provided;
- use and understand molecular and ionic equations;
- use the mole concept.

### Background information

An acid neutralises a base to form a salt and water. Hydrochloric acid and sodium hydroxide are completely ionised in water. We say they are a strong acid or base because they are completely ionised in solution. The ions present in hydrochloric acid are  $\text{H}^+(\text{aq})$  and  $\text{Cl}^-(\text{aq})$  and in sodium hydroxide are  $\text{Na}^+(\text{aq})$  and  $\text{OH}^-(\text{aq})$ .



You are going to use the technique of **titration** to produce a sodium chloride solution.

Titration is a very accurate way of investigating the reaction of two solutions. It can be used to analyse the amount of a particular substance in a solution. This is known as **quantitative analysis**. In a titration, one solution is placed in a burette and the other is placed in a conical flask using a pipette. The solution in the burette is then run into the conical flask until there is a complete reaction. In this case you will completely neutralise a solution of hydrochloric acid with sodium hydroxide solution. You will use an indicator to tell you when there is complete neutralisation. The indicator changes colour at the exact point of neutralisation. In this case you may use any acid-base indicator because you will be titrating a strong acid with a strong base.

### Questions

- Write the word and symbol equation for the reaction of hydrochloric acid with sodium hydroxide.
  - Write the equation again, this time using the ion symbols.
  - Only two of the ions you have written in 1(b) take part in the neutralisation reaction. Write the neutralisation equation without the **spectator ions**. The spectator ions are those that appear on both sides of the equation.
  - Sodium hydroxide is a soluble base. What is the name given to soluble bases?

### Safety

	You must wear eye protection throughout this experiment.
	Sodium hydroxide and hydrochloric acid are <b>corrosive</b> . (Although the solutions are very dilute, you should mop up any spillages and rinse any solution off your skin or clothing with water).

Always use a pipette filler, or other suitable safety device. Never be tempted to use your mouth to draw liquid into the pipette.

## Appendix 2

**Procedure**

1. Rinse two beakers with deionised water. Label one beaker *alkali* and wash this out with a little of the  $0.1 \text{ mol dm}^{-3}$  sodium hydroxide solution. Do this twice to ensure that any water used during the rinsing of the beaker will not dilute the sodium hydroxide solution you are about to put in the beaker. Fill the beaker about half full with the sodium hydroxide solution.

Now label the other beaker *acid* and after rinsing with water, wash it out twice using small volumes of hydrochloric acid before filling this half full with the acid solution. At the moment you do not know the exact concentration of the hydrochloric acid solution. The titration you do will allow you to calculate this.

2. Pipette exactly  $25.0 \text{ cm}^3$  sodium hydroxide solution into a clean conical flask (Fig. 1.1). The pipette can be cleaned in a similar way to the beakers, remembering to finish by washing it out with a little of the alkali solution twice to ensure no dilution will take place when using the pipette.

In this case it does not matter if there is some deionised water left in the flask after rinsing it. Now add one or two drops of acid-base indicator.

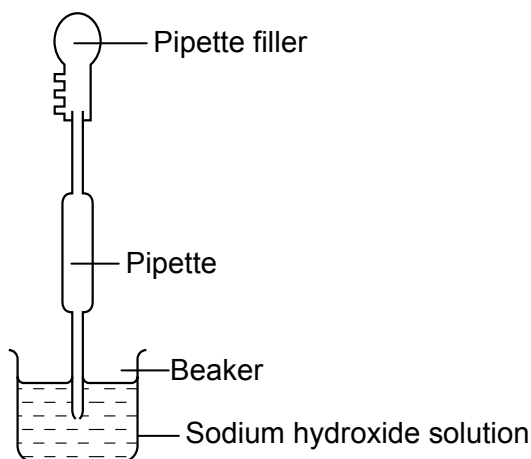

**Figure 1.1** A pipette safety filler is used to draw a measured volume of sodium hydroxide solution from the beaker into the pipette.

3. Once the burette has been rinsed and washed out with the acid solution, fill it nearly to the top (Fig. 1.2).

Clamp the burette carefully and run a little acid through into the beaker until the tip becomes full.

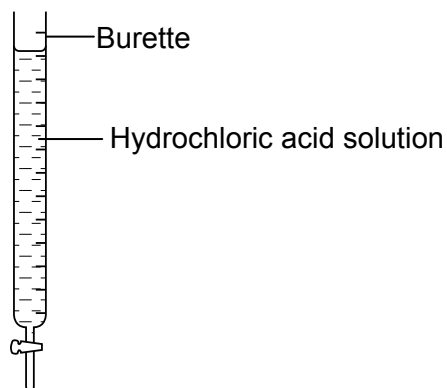

**Figure 1.2** Fill the burette with hydrochloric acid solution and ensure the tip is full.

## Appendix 2

4. Now read the burette and record the reading in the middle row of a table like the one below. Be careful that your eye is level with the bottom of the meniscus or your reading will not be accurate (Fig. 1.3).

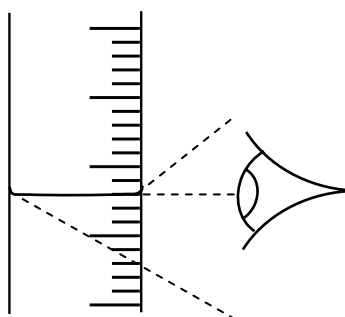

Figure 1.3

	<i>rough titration</i>	<i>1</i>	<i>2</i>
<i>final burette reading/cm<sup>3</sup></i>			
<i>initial burette reading/cm<sup>3</sup></i>			
<i>volume of acid added/cm<sup>3</sup></i>			

5. Place the conical flask below the burette on a piece of white paper. Run the acid into the flask fairly quickly, shaking it all the time. As soon as the colour of the indicator changes, close the tap and note the final burette reading. Record this result in your table above your initial reading. Subtract the initial reading from the final reading to give you the volume of acid added.
6. The first titration is a rough titration to give you an idea of the volume you need to add to exactly neutralise the acid. It is quite likely that you added a slight excess of acid as you were doing the titration quickly. Now repeat steps 2 to 5 but this time run in the acid quickly until you reach about 1 cm<sup>3</sup> less than the volume you added in the rough titration. Swirl the contents of the flask and add one drop of acid at a time from the burette until the indicator just changes colour. Record this volume. This should represent the exact volume you need to add to neutralise 25 cm<sup>3</sup> of 0.1 mol dm<sup>3</sup> of sodium hydroxide solution.
7. To ensure that you have a reliable volume of alkali, you should repeat the whole titration again until you get two readings that agree within 0.05 cm<sup>3</sup>.
8. Now you are sure of the volume of sodium hydroxide you require, repeat the titration without using the indicator. This should give you a pure sodium chloride solution, without any excess acid or alkali.
9. Evaporate all the water away from a small sample of your neutral solution using the apparatus in Fig. 1.4. Be sure to adjust your Bunsen burner to give a suitable flame. You will be left with small, white crystals of sodium chloride.

## Appendix 2

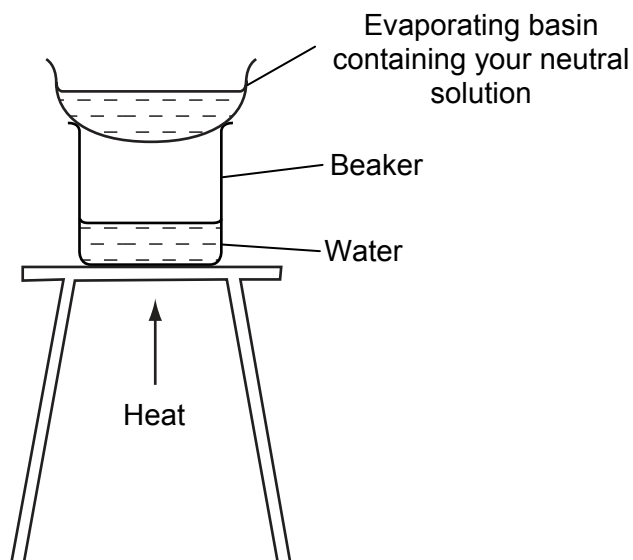

Figure 1.4

## Questions

- 2 (a) How many moles of NaOH were present in 25.0 cm<sup>3</sup> solution?
- (b) How many moles of HCl were present in the volume of acid you used to neutralise the NaOH solution? To calculate this you will need to refer to the equations you wrote in Question 1.
- (c) What was the exact concentration of the hydrochloric acid in mol dm<sup>-3</sup>?
- (d) How many moles of sodium chloride were produced in the solution in the conical flask?
- (e) What mass of salt was produced in the neutral solution?
- 3 Look back at the experimental procedure.
- (a) Why was the conical flask placed on a piece of white paper?
- (b) Why were the pipette and the burette washed with the solutions they were going to contain?
- (c) Why was the conical flask not washed with the alkali solution it was going to contain?
- (d) Explain why it does not matter if there is water already in the flask.
- (e) Explain why a conical flask was used and not a beaker.

## Appendix 2

## 1. Making salt – an introduction to some basic techniques – Teachers' Notes

This practical focuses on revising some basic techniques, such as the correct use of the Bunsen burner when heating. It gives students the opportunity to set up and manipulate apparatus and provides an introduction to a simple titration. Students will also record their results in a table.

### Learning outcomes

These are printed on the Student Sheet.

### A suggested approach

If students have not used a burette or pipette before, it would be sensible to spend a few minutes demonstrating the techniques involved in titration.

The Student Sheet gives full information about how to do the practical. Students could prepare for the practical session by reading the sheet in advance and answering Question 1. The students should finish the titration in a 1-hour session. The neutral sodium chloride solutions should be kept if you intend to evaporate off the water. It is motivating and fun for students to actually see the product that they have made and the second lesson could also be used to go through the mole calculations. It is also important to remind students about the correct use of the Bunsen burner.

### Technical information

Requirements per student/group:

#### ***For the titration***

Two 100 cm<sup>3</sup> beakers

25.0 cm<sup>3</sup> pipette

Pipette filler or equivalent safety device

50.0 cm<sup>3</sup> burette

Conical flask

Sheet of white paper or a white tile

Wash bottle and deionised water

0.10 mol dm<sup>-3</sup> NaOH(aq) – about 80 cm<sup>3</sup> (**corrosive**)

Approximately 0.1 mol dm<sup>-3</sup> HCl(aq) – about 80 cm<sup>3</sup> (**irritant**)

Stoppered flask to store a sample of the neutral solution prepared

#### ***For the evaporation of the neutral solution***

Evaporating basin

250 cm<sup>3</sup> beaker

Tripod and gauze

Heating mat

Bunsen burner

### Safety

The main points are included on the Student Sheet but it is the teacher's responsibility to ensure that a full risk assessment is carried out prior to the practical session(s). MSDS sheets should be consulted so that the correct action can be taken in event of a spillage and/or accident.

## Appendix 2

**Answers to questions on the Student Sheet**

- 1** (a) sodium hydroxide + hydrochloric acid → sodium chloride + water  
 $\text{NaOH(aq)} + \text{HCl(aq)} \rightarrow \text{NaCl(aq)} + \text{H}_2\text{O(l)}$
- (b)  $\text{Na}^+(\text{aq}) + \text{OH}^-(\text{aq}) + \text{H}^+(\text{aq}) + \text{Cl}^-(\text{aq}) \rightarrow \text{Na}^+(\text{aq}) + \text{Cl}^- + \text{H}_2\text{O(l)}$
- (c)  $\text{H}^+(\text{aq}) + \text{OH}^-(\text{aq}) \rightarrow \text{H}_2\text{O(l)}$
- (d) Alkalis.
- 2** (a) Moles of NaOH in  $25\text{cm}^3$   $0.1 \text{ mol dm}^{-3} = 0.1 \times 25/1000 = 2.5 \times 10^{-3} \text{ mol}$
- (b) This will be the same as **2(a)** above.
- (c) This is dependent on the volume of HCl used but it will be approximately  $0.1 \text{ mol dm}^{-3}$ .
- (d) This will be the same numerical answer as in **2(a)** and **2(b)**.
- (e) The moles given in **2(d)** are multiplied by  $M_r \text{ NaCl}$  (58.5).
- 3** (a) To see the end point more clearly.
- (b) To ensure there was no dilution when they were filled with the solutions to be titrated.
- (c) So that no extra moles of NaOH were present in the flask.
- (d) The amount of water present does not affect the moles of NaOH that were pipetted into the flask.
- (e) The sloping sides prevent splashes, which would lose moles of the acid or alkali and make the titration inaccurate.

## Appendix 2

**3. How much iron is there in an iron tablet? – Student Sheet**

In this practical you will have the opportunity to perform a quantitative analysis using the technique of titration. You are going to analyse an iron tablet to find out how much iron is actually present in it.

Titration involving potassium manganate(VII) may form part of your Practical Assessment.

**Intended lesson outcomes**

By the end of this practical you should be able to:

- perform a titration involving potassium manganate(VII);
- read a burette and use a pipette;
- use a volumetric flask;
- record your titration results appropriately in tables you have drawn yourself;
- use and understand an ionic equation;
- use the mole concept to perform calculations.

**Background information**

Iron performs a vital role in our bodies. It is present in red blood cells and forms part of the haemoglobin molecule, which combines with oxygen from the lungs. The oxygen is then transported all round the body. When young people are growing rapidly, the body may not have enough iron and this causes anaemia. This can be remedied by a course of 'ferrous sulphate' tablets, often known as iron tablets.

The iron in iron tablets is in the form of hydrated iron(II) sulphate (sometimes called ferrous sulphate). As the name iron(II) suggests, the  $\text{Fe}^{2+}$  ion is present. To determine just how much  $\text{Fe}^{2+}$  is in each tablet, we can react the  $\text{Fe}^{2+}$  ions with manganate(VII) ions, which have a formula  $\text{MnO}_4^-$ .

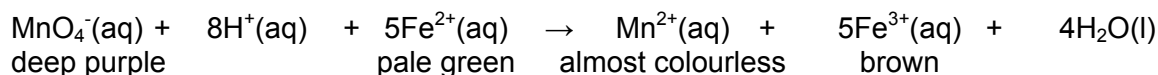



Although this ionic equation may appear complicated at this point in your course, you can see from the colours that the deep purple of the  $\text{MnO}_4^-(\text{aq})$  will disappear when the reaction is complete.

The end point is when the addition of one extra drop of potassium manganate(VII) solution turns the solution in the conical flask to a pale pink colour.

**Question**

- 1 Explain why this volumetric analysis does not require an indicator.

**Safety**

	You must wear eye protection throughout this experiment.
	1.0 mol dm <sup>-3</sup> sulphuric acid is <b>irritant</b> . Wash all spillages with plenty of water.

Always use a pipette filler, or other suitable safety device. Never be tempted to use your mouth to draw liquid into the pipette.



## Appendix 2

**Procedure**

1. Accurately weigh **two** iron tablets and record their mass.
2. Grind up the tablets with about 5 cm<sup>3</sup> of 1.0 mol dm<sup>-3</sup> sulphuric acid, using a pestle and mortar. Transfer this into a 100 cm<sup>3</sup> volumetric flask. Use further small volumes of the dilute sulphuric acid to rinse the ground-up tablets into the flask, until no traces of the iron tablets are left in the mortar.
3. Add more 1.0 mol dm<sup>-3</sup> sulphuric acid to make the volume in the volumetric flask exactly 100.0 cm<sup>3</sup>. Stopper the flask and shake it thoroughly to mix the solution. Not all of the outer coating of the tablets will dissolve. This does not matter as it does not contain any Fe<sup>2+</sup> ions.
4. Use a pipette and pipette filler to withdraw 10.0 cm<sup>3</sup> of the tablet solution and transfer it into a clean conical flask.
5. Wash a 100 cm<sup>3</sup> beaker with deionised water and then twice with small volumes of the 0.0050 mol dm<sup>-3</sup> potassium manganate(VII) solution you are going to use. Now half fill the beaker with the potassium manganate(VII) solution and use this to fill the burette. Remember that the burette does not have to be filled to the 0.00 cm<sup>3</sup> mark. Make sure that you run some of the solution back into the beaker to ensure that the tip of the burette is full. Read the volume of potassium manganate (VII) solution in the burette. In this case the colour of the potassium manganate(VII) solution is so intense that you cannot see the bottom of the meniscus so you must use the top of the meniscus to measure the volume.
6. Draw up a table in which you can record your titration results. Label the rows and columns, using the appropriate units. Think about which value you will need to subtract from which when deciding on the order of your rows.
7. Perform one rough titration, followed by two accurate titrations that agree within 0.05 cm<sup>3</sup> and record the results in your table.

**Questions**

- 2 (a) How many moles of MnO<sub>4</sub><sup>-</sup>(aq) were added from the burette?  
 (b) How many moles of Fe<sup>2+</sup>(aq) were present in 10.0 cm<sup>3</sup> of the iron tablet solution?  
 (c) How many moles of Fe<sup>2+</sup>(aq) were present in 100.0 cm<sup>3</sup> of the tablet solution?  
 (d) What is the mass of iron in the two tablets?  
 (e) Find out the mass of iron that the manufacturer states is in one tablet. How does your result compare?  
 Suggest why there are differences.  
 (f) If you were to repeat this experiment, how would you make sure that your result was as accurate as possible?
- 3 The reaction you have performed can be written as two half equations.  
 (a) Use only the ion symbols for iron(II) and iron(III) to write a half equation showing the oxidation reaction. Use e<sup>-</sup> for the electron that is lost.  
 (b) The other half equation is the reaction of the manganate(VII) ion. What type of reaction will this be?
- 4 In air, an aqueous solution of iron(II) ions will oxidise easily to iron(III) ions. The addition of dilute sulphuric acid prevents this. However, there is another reason for adding dilute sulphuric acid. What is the other reason?

## Appendix 2

**3. How much iron is there in an iron tablet? – Teachers' Notes**

If you have used Practicals 1 and 2 in Appendix 1 of this booklet, students should have developed good techniques in titration. This volumetric analysis introduces the potassium manganate(VII) titration. In the practical scheme in Appendix 1 this is placed very early in the course and is intended to cover mole calculations and further develop skills that will be tested in the practical examination. It is not, at this stage, appropriate to spend time on a detailed explanation of the redox reaction as this comes up in the A2 part of the course. However, Question 3 on the Student Sheet should be accessible to students with the knowledge they have gained from their pre-A level course.

**Learning outcomes**

These are printed on the Student Sheet.

**A suggested approach**

Set the scene by explaining the context. Iron deficiency, or anaemia, affects many people and particularly the young. 'Ferrous sulphate' tablets, often just called iron tablets, rectify this deficiency. Iron deficiency may be the result of not eating enough foods containing iron and a change in diet to include more iron-rich food is often recommended to patients.

When drug companies manufacture iron tablets they put a set amount of iron into each tablet. This is usually written on the packet. One way a drug company can check the iron content of its tablet is to analyse it using this titration.

The Student Sheet gives full information about how to do the practical. Students could prepare for the practical session by reading the sheet in advance and answering Question 1.

The students should finish the titration in a 1-hour session.

**Technical information**

Requirements per student/group:

100 cm<sup>3</sup> beaker

100.0 cm<sup>3</sup> volumetric flask

Filter funnel

10.0 cm<sup>3</sup> pipette

Pipette filler

50.0 cm<sup>3</sup> burette

100 cm<sup>3</sup> conical flask

Pestle and mortar

Sheet of white paper or a white tile

Wash bottle and deionised water

0.0050 mol dm<sup>-3</sup> KMnO<sub>4</sub>(aq) – about 100 cm<sup>3</sup> \* See notes 2 and 3 below

Approximately 1 mol dm<sup>-3</sup> H<sub>2</sub>SO<sub>4</sub>(aq) – about 120 cm<sup>3</sup>

Two 'ferrous sulphate' tablets

Access to the packet showing the mass of iron in each tablet

Access to a balance weighing to 0.01 g

**Notes**

1. If brown or red colours are seen during the titrations, this will produce inaccurate results. The remedy is to add more dilute sulphuric acid.
2. The packet of iron tablets often describes the iron tablets as '200 mg tablets'.
3. If two '200 mg tablets' are used, then the expected volume of 0.0050 mol dm<sup>-3</sup> KMnO<sub>4</sub>(aq) will be 28.60 cm<sup>3</sup> per titration. If the mass of iron is 200 mg, then the volume will be 14.30 cm<sup>3</sup>.

## Appendix 2

**Safety**

The main points are included on the Student Sheet but it is the teacher's responsibility to ensure that a full risk assessment is carried out prior to the practical session(s). MSDS sheets should be consulted so that the correct action can be taken in event of a spillage and/or accident.

**Answers to questions on the Student Sheet**

- 1 The reaction is self-indicating. The end point of the titration is shown when one extra drop of  $\text{KMnO}_4(\text{aq})$  does not go colourless but turns the reacting solution a pale pink colour.
  - 2 (a) Moles of  $\text{MnO}_4^-$  depend on the volume of solution run in from the burette.  
Moles  $\text{MnO}_4^- = \text{concentration } \text{MnO}_4^-(\text{aq}) \text{ (i.e. } 0.0050 \text{ mol dm}^{-3}\text{)} \times \text{volume delivered from burette}/1000$
  - (b) Moles of  $\text{Fe}^{2+}(\text{aq})$  in  $10.0 \text{ cm}^3 = 5 \times$  the answer given in **1(a)**.
  - (c) Since a  $100 \text{ cm}^3$  solution was made up from the two tablets: moles  $\text{Fe}^{2+}(\text{aq}) = 10 \times$  answer in **(b)**.
  - (d) The moles given in **2(c)** are multiplied by  $A_r \text{ Fe (56)}$ .
  - (e) Look for an appreciation of the limitations of the experiment. The reading of the burette is not likely to be the most significant error, as the scale can be read to  $\pm 0.05 \text{ cm}^3$ . However, it may be that some of the  $\text{Fe}^{2+}$  was oxidised by the air. Perhaps the crushing operation did not allow all of the contents of the tablet to dissolve. Look for sensible evaluations of technique.
  - (f) This may depend on what is said in **(e)** but also look for sensible comments about using more tablets in case there is a variation of mass between tablets, or to make the weighing more accurate. Students may suggest that a balance that reads to  $0.001 \text{ g}$  should be used. As the usual mass of iron in a tablet is  $200 \text{ mg}$ , this is a sensible suggestion.
- 3 (a)  $\text{Fe}^{2+}(\text{aq}) \rightarrow \text{Fe}^{3+}(\text{aq}) + \text{e}^-$
  - (b) Reduction.
- 4  $\text{H}^+(\text{aq})$  is an essential reactant as it appears in the reaction equation.

## Appendix 2

**5. What is the volume of 1 mole of hydrogen gas? – Student Sheet**

One mole of any gas occupies the same volume when measured under the same conditions of temperature and pressure. In this experiment you will calculate the volume of 1 mole of hydrogen at room temperature and pressure.

**Intended lesson outcomes**

By the end of this practical you should be able to:

- further develop skills in manipulating apparatus and accurate measurement;
- use the mole concept;
- calculate the molar volume at room temperature and pressure.

**Background information**



Magnesium reacts with acid to give a salt and water.

**Question**

- 1 Write the word and balanced equation for the reaction of magnesium with dilute hydrochloric acid.

If the mass of magnesium is measured, then the moles of magnesium can be calculated. Once this amount is known, you can use the equation you have written in Question 1 to calculate the moles of hydrogen that are produced. If the volume of this amount of hydrogen is measured, then you can calculate the volume of 1 mole, also known as the **molar volume**.

**Safety**

	You must wear eye protection throughout this experiment.
	Hydrochloric acid is <b>corrosive</b> . (Although the solution is very dilute, you should mop up any spillages and rinse any solution off your skin or clothing with water).
	Magnesium ribbon is <b>highly flammable</b>

**Procedure**

1. Clean a piece of magnesium ribbon about 3.5 cm long then weigh it accurately. This should weigh between 0.02 g and 0.04 g; if not, adjust the length of magnesium until it does.
2. Place about 30 cm<sup>3</sup> 1M hydrochloric acid in the burette and top this up to 50 cm<sup>3</sup> with water.
3. Push the magnesium into the top of the burette, above the liquid level, so that it is held by its own tension (see Fig. 5.1).
4. Add 50 cm<sup>3</sup> of water to a crystallising dish.
5. Quickly invert the burette into the water. Provided you do this quickly and carefully, you will lose very little of the liquid in the burette. The liquid level should be on the graduated scale. If it is not, open the tap for a moment to allow the level to drop. Record the burette reading.

## Appendix 2

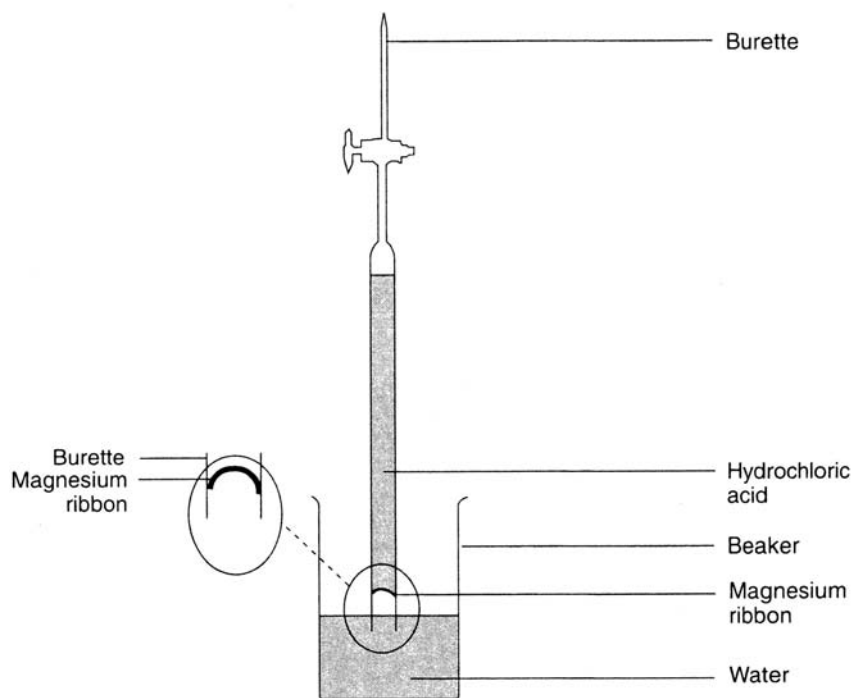

Figure 5.1

6. Clamp the burette and record the volume. Remember that the scale is now upside down.
7. Soon the acid will diffuse down to the magnesium and it will begin to react. When the magnesium has all reacted, note the new volume and calculate the volume of hydrogen produced.
8. Record the temperature of the laboratory.

**Questions**

- 2 (a) How many moles of magnesium did you use?
  - (b) How many moles of hydrogen are produced? To calculate this you will need to refer to the equation you wrote in Question 1.
  - (c) What is the volume of 1 mole of hydrogen gas at the temperature and pressure of the laboratory?
- 3 The general gas equation is  $pV = nRT$ , where  $p$  is the pressure,  $T$  is the temperature and  $R$  is the ideal gas constant. This can be used to calculate the volume of gas as standard temperature and pressure (s.t.p.). Since  $n$ ,  $R$  and  $p$  stay the same, the equation for calculating this is

$$\frac{V_1}{T_1} = \frac{V_2}{T_2}$$

Calculate the molar volume at s.t.p.

## Appendix 2

**5. What is the volume of 1 mole of hydrogen gas? – Teachers' Notes**

In this practical students react magnesium quantitatively with hydrochloric acid. They collect the hydrogen gas and calculate the molar volume.

**Learning outcomes**

These are printed on the Student Sheet.

**A suggested approach**

Begin by explaining to students that the molar volume of any gas is always the same at the same temperature and pressure. In this experiment they are going to calculate this volume under room conditions. Inverting the burette safely and with little loss of liquid is not difficult but you will need to demonstrate the procedure before they start. Bring the lip of the crystallising dish up to the top of the burette and rest it there. Now swing the tap end round and upright. If the liquid level is not on the scale, open the tap momentarily to allow the liquid level to drop down to the scale. The actual practical should take approximately 30 minutes. There will then be time for students to do the calculations. Question 3 uses the general equation. If this has not been covered in theory, you may wish to give a very brief explanation, while saving a more rigorous explanation until later. The main point is that the volume of a gas varies in direct proportion to the temperature.

**Technical information**

Requirements per student/group:

Crystallising dish

50.0 cm<sup>3</sup> burette

Clamp stand

1 mol dm<sup>-3</sup> hydrochloric acid

0.02 g – 0.04 g standard magnesium ribbon (this is about 3.5 cm)

Thermometer

**Safety**

The main points are included on the Student Sheet but it is the teacher's responsibility to ensure that a full risk assessment is carried out prior to the practical session. MSDS sheets should be consulted so that the correct action can be taken in event of a spillage and/or accident.

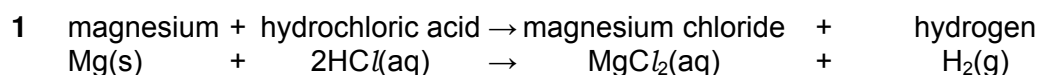
**Answers to questions on the Student Sheet**

2 (a) Moles of Mg used = mass of Mg/ $A_r(\text{Mg})$

It should be between  $8.33 \times 10^{-4}$  mol and  $1.67 \times 10^{-3}$  mol.

(b) This depends on the moles of Mg used. It will be the same value as calculated in (a).

(c) This will depend on the temperature and pressure of the room but students can expect an answer of approximately 24 dm<sup>3</sup>.

3 The volume at s.t.p. (0°C) will be approximately 22.4 dm<sup>3</sup>.

## Appendix 2

## 8. Measuring the enthalpy changes of exothermic and endothermic reactions – Student Sheet

Chemical reactions are often accompanied by energy changes. These experiments show you how energy changes can be measured.

### Intended lesson outcomes

By the end of this practical you should:

- have further developed skills in manipulating apparatus and accurate measurement of temperature;
- know that some chemical reactions are accompanied by energy changes in the form of heat energy;
- know that energy changes can be exothermic ( $\Delta H$ , negative) or endothermic ( $\Delta H$ , positive);
- be able to calculate enthalpy changes from your experimental results using enthalpy change =  $mc\Delta T$ .

### Background information

To make a chemical bond, another bond must first be broken. It is the sum of the energy changes in making and breaking bonds that results in the overall energy change in a reaction. **Enthalpy** is the stored energy in a compound. It has a symbol **H**. If some of this stored energy is released during a reaction, the surroundings heat up. This is an exothermic reaction and we say that the change of enthalpy,  $\Delta H$ , is negative. ( $\Delta$  means *change of*.) However, if energy is absorbed during a reaction, then  $\Delta H$  is positive and the surroundings cool down.

To measure enthalpy changes you are going to use a polystyrene cup as a calorimeter (Fig. 8.1). A calorimeter is any container that is used to measure energy changes from chemical reactions.

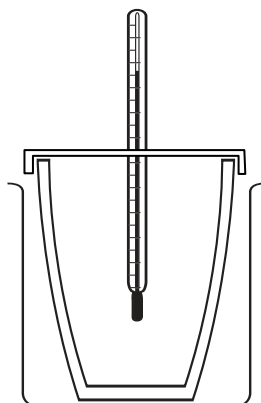

Figure 8.1





### Question

- 1 The simple apparatus in Fig. 8.1 is very effective in minimising energy losses and this is important if we are going to measure accurately any energy changes arising from reactions.

Explain three ways in which heat energy loss is minimised using this apparatus.

## Appendix 2

## Safety

	You must wear eye protection throughout this experiment.
 	Copper sulphate is <b>harmful</b> and <b>dangerous for the environment</b>
	Zinc powder is <b>highly flammable</b> .

## Procedure

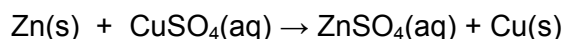
**Experiment 1: The displacement reaction between zinc and copper(II) sulphate**

Use a measuring cylinder to pour 50 cm<sup>3</sup> of 0.2 mol dm<sup>-3</sup> copper(II) sulphate into the polystyrene cup. Weigh out about 1 g of powdered zinc onto a piece of paper. This is an excess (more than is needed to react with the copper(II) sulphate) so it does not need to be measured accurately. Record the initial temperature of the solution in the cup and then add the powdered zinc. Stir the solution gently and constantly with the thermometer until the temperature stops changing. Record the final temperature reached. Rinse the cup with water ready for use in Experiment 2.

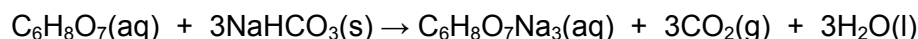
**Experiment 2: The reaction between citric acid and sodium hydrogen carbonate**

Use the same procedure as in Experiment 1 but this time use 25 cm<sup>3</sup> of 1 mol dm<sup>-3</sup> citric acid and weigh out 8 g sodium hydrogen carbonate. This reaction froths up, so add the powdered solid slowly enough to prevent it coming over the top of the cup. Keep stirring and record the maximum temperature change.

**Processing your results**

We assume that all the energy in these reactions is exchanged with the surrounding water and no energy is transferred to the air, the glass of the thermometer, or the polystyrene cup. We know that the specific heat capacity of water, *c*, is approximately 4.2 J g<sup>-1</sup> K<sup>-1</sup>. This means that 4.2 J of energy will raise the temperature of 1 g of water by 1 K. (This is the same as 1°C.) As the solution is dilute, we also assume it has the same specific heat capacity of water and the same mass. 1 cm<sup>3</sup> of water weighs 1 g.

We are going to use the relationship:

enthalpy change = mass x specific heat capacity of the solution x temperature change

enthalpy change =  $mc\Delta T$

For each experiment, calculate the enthalpy change that took place.

To complete the calculations, chemists express their results as enthalpy changes per mole of equation. In the first reaction, 1 mole of copper(II) sulphate appears in the balanced equation; in the second reaction there is 1 mole of citric acid.

Work out the enthalpy change per mole and indicate whether it is exothermic or endothermic by using '+' or '-' next to your enthalpy values.



## Appendix 2

**Questions**

- 2 (a) In Experiment 1, zinc was in excess. Calculate the moles of copper(II) sulphate used and the moles of zinc used. Now use the reacting moles in the balanced equation to show that zinc is indeed the reactant that is in excess.
- (b) Similarly, show that sodium hydrogen carbonate is the reagent in excess.
- 3 Write the ionic equations for the reactions in Experiments 1 and 2. Do not include any spectator ions.

## Appendix 2

## 8. Measuring the enthalpy changes of exothermic and endothermic reactions – Teachers' Notes

In these two experiments students have the opportunity to accurately measure a temperature change and calculate the enthalpy changes of the reactions.

### Learning outcomes

These are printed on the Student Sheet.

### A suggested approach

Students will already have some familiarity with exothermic and endothermic reactions but it will probably be worth reminding them about this before they start. The concept of bond breaking and bond making and how this contributes to the overall enthalpy change is mentioned in the 'Background information' section on the Student Sheet, as is the requirement to minimise heat losses. Under the 'Procedure', the concept of having one reactant in excess is described but the reason is explored in Question 2.

The practical will take about 40 minutes, leaving time for the 'Processing your results' section to be tackled. Students could finish off calculations and answer the questions for homework.

### Technical information

Requirements per student/group:

Polystyrene cup with lid

Glass beaker large enough to stand the polystyrene cup in but not much larger (see Fig. 8.1 on the Student Sheet)

Thermometer,  $-5^{\circ}\text{C}$  to  $50^{\circ}\text{C}$

$50\text{ cm}^3$  and  $25\text{ cm}^3$  measuring cylinders

$1\text{ mol dm}^{-3}$  citric acid, approximately  $30\text{ cm}^3$

$0.2\text{ mol dm}^{-3}$  copper(II) sulphate, approximately  $60\text{ cm}^3$  (**harmful**)

$1\text{ g}$  zinc powder (**highly flammable**)

$8\text{ g}$  sodium hydrogen carbonate

Access to a balance weighing  $0.01\text{ g}$

### Safety

The main points are included on the Student Sheet but it is the teacher's responsibility to ensure that a full risk assessment is carried out prior to the practical session. MSDS sheets should be consulted so that the correct action can be taken in event of a spillage and/or accident.

### Processing the results

Although this is described in the Student Sheet, students may need help in understanding the calculation per mole of reaction. The approximate values are given below.

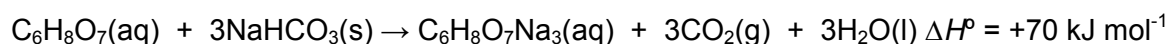
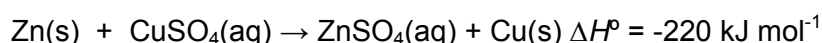

### Answers to questions on the Student Sheet

- Polystyrene is a good insulator, so heat loss from the sides is minimised. The lid prevents energy loss from the top and the glass beaker provides another layer of insulation for the sides, as the air trapped in the beaker is also a poor conductor.
- (a) If  $1\text{ g}$  of powdered zinc is used, then moles of  $\text{Zn} = 1/65 = 0.015\text{ mol}$ .

## Appendix 2

The moles of  $\text{CuSO}_4$  in solution =  $0.2 \times 50/1000 = 0.01$  mol.

Since the equation involves 1 mole of  $\text{CuSO}_4$  reacting with 1 mole of Zn, the zinc is in excess.

**(b)** If 8 g of sodium hydrogen carbonate is used, moles  $\text{NaHCO}_3 = 8/84 = 0.095$  mol.

Moles of citric acid =  $1 \times 25/1000 = 0.025$  mol.

From the equation, 3 moles of  $\text{NaHCO}_3$  exactly react with 1 mole citric acid.  $3 \times 0.025 = 0.075$  mol. This is 0.02 mol less than the actual moles added, so  $\text{NaHCO}_3$  is in excess.

**(c)** To ensure complete reaction:

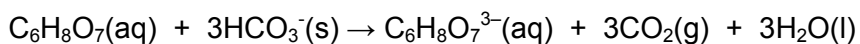
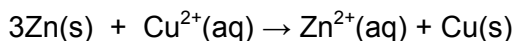

## Appendix 2

## 12. The effect of altering the concentration on an equilibrium reaction – Student Sheet

Your teacher has introduced you to Le Chatelier's Principle. You are now going to use this principle to predict the effect of changing the concentrations of the reactants on the equilibrium position.

### Background information

Le Chatelier's Principle applies to systems in dynamic equilibrium. One way of stating this is:

*The position of the equilibrium of a system changes to minimise the effect of any imposed change in conditions.*

### Question

1 What conditions, other than concentration, could affect the position of equilibrium?

Your teacher is going to demonstrate the effects of changing the concentration of substances in this dynamic equilibrium mixture:

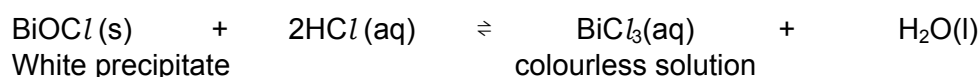

### Question

2 Explain what is meant by the terms 'reversible reaction' and 'dynamic equilibrium'.

Your teacher will prepare a solution of bismuth trichloride from bismuth oxide chloride.

### Question

3 How might your teacher prepare bismuth trichloride?

Your teacher will add water to the above equilibrium mixture.

### Questions

4 (a) Predict what you will observe when water is added.

(b) Use Le Chatelier's Principle to explain your prediction.

Following the addition of water, your teacher will add concentrated hydrochloric acid to the equilibrium mixture.

### Questions

5 What safety precautions should your teacher adopt?

6 (a) Predict what you will observe when concentrated hydrochloric acid is added.

(b) Use Le Chatelier's Principle to explain your prediction.

## Appendix 2

## 12. Introducing equilibria through two demonstrations – Teachers' Notes

This is an effective way of introducing the syllabus section on equilibria. It shows a reversible reaction and allows a dynamic equilibrium to be reached. The system at equilibrium is then subjected to changes in concentration and temperature, thus demonstrating Le Chatelier's Principle. The Student Sheet is intended to accompany the second demonstration.

### Learning outcomes

By the end of this lesson students should:

- understand what is meant by a reversible reaction and a dynamic equilibrium;
- have been introduced to Le Chatelier's Principle;
- have observed the effects of changes of concentration and pressure on the equilibrium position.

### A suggested approach

Begin the lesson with Demonstration 1. Use this to cover the intended learning outcomes. With discussion of the underlying theory, this could easily take 25 minutes. Now give out the Student Sheet, 'The effect of altering the concentration on an equilibrium reaction', and ask students to use it to predict what will happen in Demonstration 2. Test their predictions by doing the second demonstration.

### Demonstration 1: The equilibrium between $\text{Co}(\text{H}_2\text{O})_6^{2+}(\text{aq})$ and $\text{CoCl}_4^{2-}(\text{aq})$

#### Theory

The equilibrium is:





This experiment allows you to demonstrate the effect of concentration and temperature on the equilibrium position of this reaction. The changes seen are in accordance with Le Chatelier's Principle.

#### Technical information

Six boiling tubes and a rack  
 100 cm<sup>3</sup> measuring cylinder  
 Three 250 cm<sup>3</sup> beakers  
 Two dropping pipettes  
 Access to a balance  
 4 g cobalt chloride-6-water ( $\text{CoCl}_2 \cdot 6\text{H}_2\text{O}$ )  
 100 cm<sup>3</sup> of concentrated hydrochloric acid  
 200 cm<sup>3</sup> of crushed ice

#### Safety

	<b>You must wear eye protection throughout this experiment.</b>
	Hydrochloric acid is <b>corrosive</b> . (It has a highly exothermic reaction with water, so always add the concentrated acid to the aqueous solution, never do it the other way round).

It is the teacher's responsibility to ensure that a full risk assessment is carried out prior to the demonstration.



## Appendix 2

this slowly into another boiling tube containing about 12 cm<sup>3</sup> water. (Never do this the other way round!) A white precipitate of bismuth oxide chloride immediately appears. Transfer the mixture into a 100 cm<sup>3</sup> beaker and add another 2 cm<sup>3</sup> of concentrated hydrochloric acid and stir. The precipitate re-dissolves. Now add 25 cm<sup>3</sup> of water and the precipitate re-appears. Adding 3 cm<sup>3</sup> of concentrated hydrochloric acid will again shift the equilibrium to the colourless side. You can continue doing this by transferring the mixture to a 250 cm<sup>3</sup> beaker.

**Answers to questions on the Student Sheet**

- 1 Temperature and pressure.
- 2 Reversible reactions take place in either direction.  
Dynamic equilibrium is one where the rate of the forward reaction is equal to the rate of the reverse reaction.
- 3 By adding hydrochloric acid to bismuth oxide chloride.
- 4 (a) A white precipitate will form.  
(b) Water appears on the right-hand side of the equilibrium equation. Adding more water is an imposed change of condition. By Le Chatelier's Principle, the equilibrium will shift to the left to minimise the effect of the added water.
- 5 Expect 'Wear safety goggles'. You might wish to point out that the risk to the eyes really started at the beginning of the demonstration. You should also add that concentrated acids often have a highly exothermic reaction if water (or a dilute solution) is added to them. Concentrated acids should always be added slowly to the water and never the other way around.
- 6 (a) The white precipitate dissolves to leave a colourless solution.  
(b) Hydrochloric acid appears on the left-hand side of the equilibrium equation. The changed condition that is imposed is that the concentration of hydrochloric acid increases in the equilibrium mixture. This imposed condition is minimised by the equilibrium shifting to the right-hand side.

## Appendix 2

### 13. Determining the value of $K_c$ for an equilibrium reaction – Student Sheet

In this experiment you have the opportunity to use the skills you have developed by doing volumetric analysis to determine an equilibrium constant.

#### Intended lesson outcomes

By the end of this practical you should:

- be able to deduce an expression for the equilibrium constant,  $K_c$ ;
- be able to calculate a value for  $K_c$  from the concentrations of substances at equilibrium;
- be able to draw up a table for the results of your calculations;
- have further developed your skills in titration techniques;
- be aware of the use of a **control** in an experiment.

#### Background information

Ethyl ethanoate is an important solvent. One way of manufacturing it is shown by the following equation.

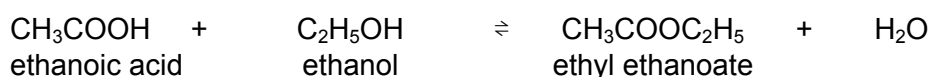



This is the equilibrium you are going to investigate. It takes a very long time for this reversible reaction to reach equilibrium. An acid catalyst, such as hydrochloric acid is used to speed up both the forward and reverse reactions. This enables the equilibrium to be reached in a much shorter time. The catalyst does not affect the value of  $K_c$ .

#### Question

- 1 What is the expression for  $K_c$  for this equilibrium?

#### Safety

	You must wear eye protection throughout this experiment.
	Glacial ethanoic acid is <b>corrosive</b> . (Mop up any spillages with plenty of water).
	Hydrochloric acid is <b>corrosive</b> .

#### Procedure

1. Your class is going to set up five boiling tubes with different starting concentrations of the various reactants. The volumes of each reactant you need to add are shown in the following table. Take great care with glacial ethanoic acid – it is pure ethanoic acid and is very corrosive.



## Appendix 2

boiling tube	volume of liquid/cm <sup>3</sup>				
	HCl (1 mol dm <sup>-3</sup> )	glacial ethanoic acid CH <sub>3</sub> COOH	ethanol C <sub>2</sub> H <sub>5</sub> OH	ethyl ethanoate CH <sub>3</sub> COOC <sub>2</sub> H <sub>5</sub>	H <sub>2</sub> O
A (control)	2	0	0	0	18
B	2	6	6	6	0
C	2	0	6	6	6
D	2	6	0	6	6
E	2	6	6	0	6

- Stopper the boiling tubes, label them and leave for a week, immersed in a bucket of water. This will keep the temperature reasonably constant and allow equilibrium to be achieved.
- After a week has passed, the reactions in tubes B, C and D need **quenching**. This prevents the position of equilibrium from changing any more. Adding water, which makes the reaction mixture very dilute, does this and stops the catalytic effect of the hydrochloric acid.

Take 10.0 cm<sup>3</sup> from each boiling tube using a pipette and pipette filler. Make each up to 100.0 cm<sup>3</sup> in a volumetric flask using deionised water. (Remember to wash the pipette with a little deionised water and then twice with a very small volume of the liquid in the boiling tube.)

Label these flasks B, C and D to correspond to the contents of the original boiling tubes.

- For tube A, pour the entire contents into a 100.0 cm<sup>3</sup> volumetric flask and make up to the 100.0 cm<sup>3</sup> mark. Wash the boiling tube twice with a little deionised water and transfer the washings. Label this flask A.
- From each volumetric flask except A, withdraw 10.0 cm<sup>3</sup> using a clean pipette and pipette filler. Transfer the liquid to a conical flask and add two or three drops of phenolphthalein indicator. Titrate this with 0.01 mol dm<sup>-3</sup> NaOH(aq). Do a rough titration followed by two accurate readings that agree within 0.1 cm<sup>3</sup>.
- Pour the entire contents of volumetric flask A, the solution made up from tube A, into a 250 cm<sup>3</sup> conical flask. Rinse the volumetric flask twice with a little deionised water and transfer the washings to the conical flask. Add phenolphthalein indicator. In this case you are not going to be able to do a rough titration, so add 0.5 cm<sup>3</sup> at a time until the indicator changes colour.

### Processing your results

Although this looks complicated, if you take it by stages it should be straightforward.

#### Stage 1

You need to know how many moles of each reactant you started with. You can calculate this if you know the density of each liquid as mass = volume x density.

	CH <sub>3</sub> COOH	C <sub>2</sub> H <sub>5</sub> OH	CH <sub>3</sub> COOC <sub>2</sub> H <sub>5</sub>	H <sub>2</sub> O
density/ g cm <sup>-3</sup>	1.05	0.79	0.92	1.0

**Worked example** – tube B, ethanoic acid:

If 6.0 cm<sup>3</sup> of ethanoic acid is added, the mass of CH<sub>3</sub>COOH = 6.0 cm<sup>3</sup> x 1.05 g cm<sup>-3</sup> = 6.3 g  
*M<sub>r</sub>* CH<sub>3</sub>COOH = 60, therefore mol CH<sub>3</sub>COOH = 6.3/60 = 0.105 mol

## Appendix 2

Now draw up a table to record the starting moles for the four liquids for each of the boiling tubes C, D and E and record the results of your calculations.

**Stage 2**

Calculate the number of moles of HCl in  $2.0 \text{ cm}^3$   $1 \text{ mol dm}^{-3}$  HCl. In this case you do not need to use density, as we already know its concentration.

For the contents of tube A, all these moles were titrated against  $0.1 \text{ mol dm}^{-3}$  NaOH. Calculate the volume of NaOH you would expect to add to neutralise the hydrochloric acid present. This should be the actual volume you used because there was only water and HCl in the mixture. This is your control and it is used to prove that the concentration of HCl is not changed by the conditions of the experiment.

**Stage 3**

There are two neutralisation reactions arising in the titrations from volumetric flasks B, C and D. The end point is when both acids are neutralised.

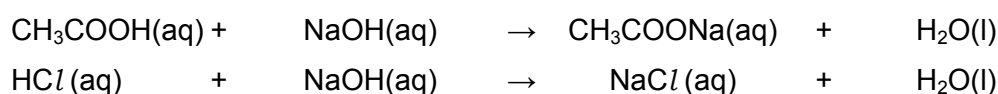

Remember, every neutralisation reaction can be expressed ionically as:

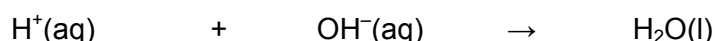

- For each titration result from flasks B, C, D and E, calculate the number of moles of  $\text{H}^+(\text{aq})$  present.
- Before doing the titrations, you diluted the solutions in the boiling tubes. This was to quench the equilibrium mixtures. First of all you only pipetted half the  $20.0 \text{ cm}^3$  of the equilibrium mixture from the boiling tube into the volumetric flask. Then you only transferred a tenth of these moles from the volumetric flask into the conical flask. The result of these two actions means that you must multiply each of your answers in (a) by 20 to give the number of moles  $\text{H}^+(\text{aq})$  in each original equilibrium mixture.
- We know from Stage 2 that the moles of  $\text{H}^+$  due to the catalyst HCl remained unchanged. Now subtract the number of moles of  $\text{H}^+$  in each tube from your answer in (b). You now have the equilibrium moles of ethanoic acid. This amount may be greater or less than the number of moles you started with.

**Stage 4**

At this stage you can calculate the moles of each substance present at equilibrium. We will show how to do this using your results for tube B.

- Moles of ethanoic acid present at equilibrium = x mol** (this is the value from Stage 3)  
These moles have not reacted because they were still in the boiling tube. You started with 0.105 moles of ethanoic acid. This means that  $0.105 - x$  moles have reacted.
- Moles of ethanol at equilibrium =  $0.103 - (0.105 - x)$**

The equation tells us that 1 mole of ethanoic acid reacts with 1 mole of ethanol. So  $0.105 - x$  moles ethanoic acid must have reacted with  $0.105 - x$  ethanol.

Look back at the table you drew up in Stage 1. For tube B you should have calculated a value of 0.103 for the starting moles of ethanol.

Therefore the number of moles of ethanol at equilibrium is the starting value 0.103 moles, minus the number of moles that have reacted,  $0.105 - x$  moles, i.e. moles of ethanol at equilibrium =  $0.103 - (0.105 - x)$

## Appendix 2

**(c) Moles of ethyl ethanoate at equilibrium = 0.0627 + (0.105 – x)**

We started with 0.0627 moles of ethyl ethanoate in tube B but because 0.105 – x moles ethanoic acid has reacted, 0.105 – x ethyl ethanoate must have been produced. The total ethyl ethanoate at equilibrium is the starting number of moles plus the number of moles produced.

**(d) Moles of water at equilibrium = 0 + (0.105 + x)**

This has increased by the same amount as ethyl ethanoate for the same reason. There was no water to start with in tube B.

In summary:

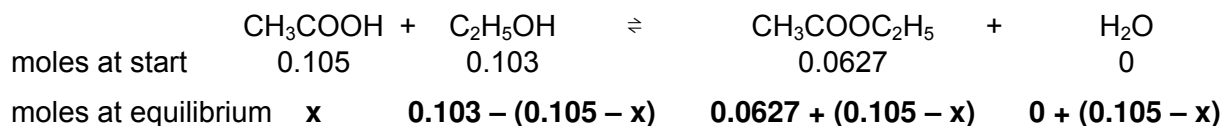
**Stage 5**

Using the number of moles of each substance at equilibrium in boiling tube B, we can calculate  $K_c$ .

The expression for  $K_c$  requires equilibrium *concentrations*. For the purposes of this calculation, all four substances are present in the same volume ( $20 \text{ cm}^3$ ), therefore these volumes cancel each other out when substituted into the equilibrium expression. So we can use the number of moles. This is not always the case.

Using your answer to Question 1 in the 'Background information' at the start of this sheet, calculate  $K_c$  for tube B.

Work through the stages again to calculate values for  $K_c$  for boiling tubes C, D and E and tabulate your results for equilibrium moles and  $K_c$  for each tube.

## Appendix 2

### 13. Determining the value of $K_c$ for an equilibrium reaction – Teachers' Notes

This experiment shows how an equilibrium constant can be measured using techniques students have already learned in their practical course to date.

#### Learning outcomes

These are printed on the Student Sheet.

#### A suggested approach

The Student Sheet gives full details of how to carry out the practical. Setting up the equilibrium mixtures can be done towards the end of a theory lesson about equilibrium constants. With careful preparation, it is safe and need not take too long. Before this lesson, fill burettes with each of the five liquids set out in Table 13.1 on the Student Sheet. This makes handling glacial ethanoic acid much safer for the students. Each student, or group of students, only needs to prepare one mixture, or two at the most. These are left in a bucket of water to try to keep the temperature reasonably constant. If you have access to a thermostatically controlled water bath, so much the better, but this is not essential.

After a week (although 3 days may well suffice), the boiling tube mixtures are at equilibrium, so the practical lesson is about titrating them to determine the equilibrium concentrations. It is only necessary for each group to titrate one of the boiling tube mixtures. As a suggestion, you could always tell students you have titrated tube A for them, since the concentration of hydrochloric acid remains the same in this *control* tube.

#### Technical information

##### Notes

1. We suggest that one student, or group, makes up one or two of the boiling tube mixtures.
2. The table on the Student Sheet gives the volumes for each boiling tube.

Requirements per student/group:

#### Setting up the mixtures

Bucket of water

Thermometer  $-5^{\circ}\text{C}$  to  $50^{\circ}\text{C}$  for putting in the bucket of water

Boiling tubes with bungs

Access to burettes containing:

- deionised water
- glacial ethanoic acid (**corrosive**)
- ethanol
- ethyl ethanoate
- $1\text{ mol dm}^{-3}$  hydrochloric acid (**irritant**)

#### Titration of the equilibrium mixtures

$10.0\text{ cm}^3$  pipette

Pipette filler

$0.01\text{ mol dm}^{-3}$  NaOH(aq)

Phenolphthalein

$100\text{ cm}^3$  conical flask

$100\text{ cm}^3$  volumetric flask

Sheet of white paper or a white tile

Wash bottle and deionised/distilled water

## Appendix 2

**Safety**

The main points are included on the Student Sheet but it is the teacher's responsibility to ensure that a full risk assessment is carried out prior to the practical session. MSDS sheets should be consulted so that the correct action can be taken in event of a spillage and/or accident.

You are strongly advised to set up the burette containing glacial ethanoic acid yourself.

**Processing the results**

Although the actual calculations look daunting, they are set out in a very logical way. However, students may still need help in understanding exactly what is happening at each stage. A sample calculation has been done in the case of boiling tube B. Students will be able to see the results of their calculations more clearly if they draw up suitable tables. These should have the appropriate row and column headings, including units. The  $K_c$  value expected is approximately 4.

The equilibrium concentrations of boiling tube mixtures C, D and E are as follows.

**Boiling tube C**

	CH <sub>3</sub> COOH	+	C <sub>2</sub> H <sub>5</sub> OH	⇌	CH <sub>3</sub> COOC <sub>2</sub> H <sub>5</sub>	+	H <sub>2</sub> O
moles at start	0		0.103		0.0627		0.333
moles at equilibrium	x		0.103 + x		0.0627 - x		0.333 - x

**Boiling tube D**

	CH <sub>3</sub> COOH	+	C <sub>2</sub> H <sub>5</sub> OH	⇌	CH <sub>3</sub> COOC <sub>2</sub> H <sub>5</sub>	+	H <sub>2</sub> O
moles at start	0.105		0		0.0627		0.333
moles at equilibrium	x		(0.105 - x)		0.0627 + (0.105 - x)		0.333 + (0.105 - x)

**Boiling tube E**

	CH <sub>3</sub> COOH	+	C <sub>2</sub> H <sub>5</sub> OH	⇌	CH <sub>3</sub> COOC <sub>2</sub> H <sub>5</sub>	+	H <sub>2</sub> O
moles at start	0.105		0.103		0		0.333
moles at equilibrium	x		0.103 - (0.105 - x)		(0.105 - x)		0.333 + (0.105 - x)

**Answer to question on the Student Sheet**

$$1 \quad K_c = \frac{[\text{CH}_3\text{COOC}_2\text{H}_5][\text{H}_2\text{O}]}{[\text{CH}_3\text{COOH}][\text{C}_2\text{H}_5\text{OH}]}$$

## Appendix 2

**15. The effect of temperature on reaction rate – Student Sheet**

This experiment investigates the effect of temperature on the rate of reaction between sodium thiosulphate and dilute hydrochloric acid.

**Intended lesson outcomes**

By the end of this practical you should be able to:

- measure the effect of temperature on a reaction rate;
- represent your results graphically and draw conclusions;
- explain, in terms of the collision theory, why temperature change affects the reaction rate.

**Background information**



When sodium thiosulphate reacts with hydrochloric acid, a precipitate of sulphur forms. The time taken for a certain amount of sulphur to form is used to measure the reaction rate. The sodium thiosulphate solution can be heated to different temperatures before hydrochloric acid is added, so the effect of increasing temperature can be measured.

The effect of temperature increase on this reaction can be predicted using the collision theory. This theory says that for a reaction to occur, particles must collide with a certain minimum energy called the **activation energy,  $E_A$** . When temperature is increased, particles have increased kinetic energy and move around faster. There is therefore an increase in the frequency of collisions.

**Question**

- 1 If sodium thiosulphate solution is heated, predict the effect of increasing the temperature on the rate of this reaction.

**Safety**

	You must wear eye protection throughout this experiment.
	Hydrochloric acid is <b>corrosive</b> .
	This reaction produces sulphur dioxide, which is <b>toxic</b> , so ensure good ventilation or use a fume cupboard. Take care not to inhale the fumes. Asthmatics need to be particularly careful.

## Appendix 2

**Procedure**

1. Measure 10 cm<sup>3</sup> of sodium thiosulphate solution and 40 cm<sup>3</sup> of water into a conical flask.
2. Measure 5 cm<sup>3</sup> of dilute hydrochloric acid in a 10 cm<sup>3</sup> measuring cylinder.
3. Warm the thiosulphate solution in the flask to the required temperature, as in Fig. 15.1.

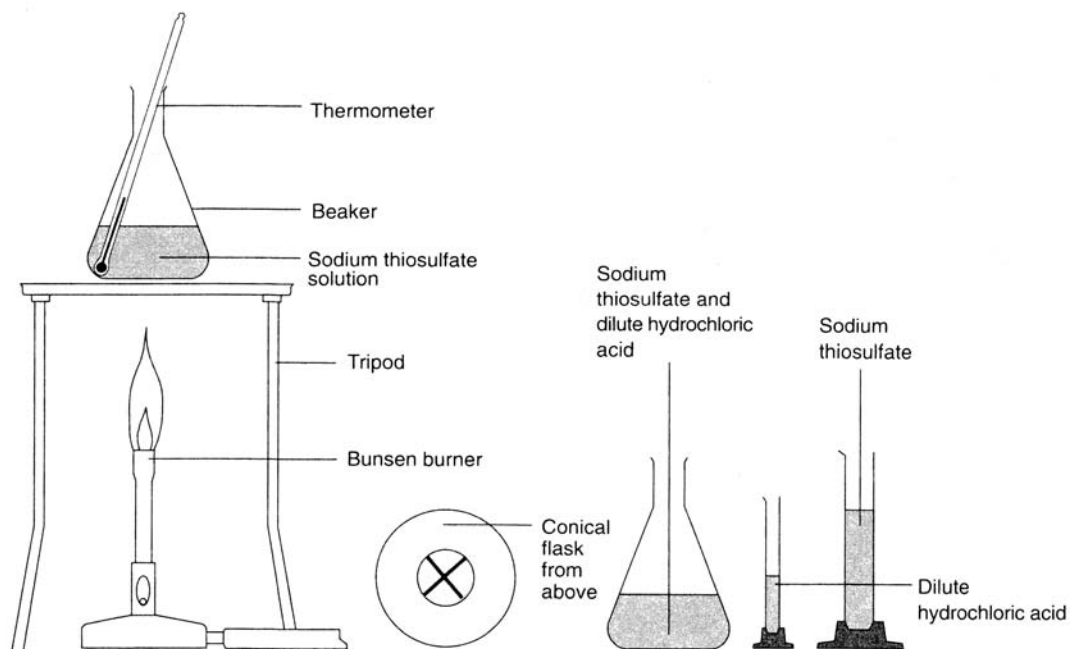
**Figure 15.1**

4. Put the conical flask over a piece of paper with a cross drawn on it.
5. Add the acid and start timing. Swirl the flask to mix the contents. Take the initial temperature of the mixture and record it in a table like the one below.
6. Repeat the experiment using different temperatures in the range 15°C to 65°C. Remember that one of your experiments can be carried out at room temperature and so will not require heating.

<i>initial temperature of the mixture in the flask/°C</i>	<i>final temperature of the mixture in the flask/°C</i>	<i>average temperature of the mixture in the flask/°C</i>	<i>time taken for the cross to disappear</i>	<i>1/time taken/s<sup>-1</sup></i>

7. Look down on the cross from above. When the cross disappears, stop timing and note the time taken. Record the final temperature of the mixture in the flask.
8. Immediately wash the solution down a sink with plenty of water.

## Appendix 2

**Processing your results**

For each set of results, calculate the average temperature and the value  $1/\text{time}$ .  $1/\text{time}$  can be taken as a measure of the rate for this reaction.

Plot a graph of  $1/\text{time}$  on the vertical ( $y$ ) axis and average temperature on the horizontal ( $x$ ) axis.

**Question**

2 What does the graph indicate about the effect of temperature on this chemical reaction?



## Appendix 2

**15. The effect of temperature on reaction rate – Teachers' Notes**

This experiment investigates the effect of temperature on the rate of the reaction between sodium thiosulphate and sulphur by using the time taken for the precipitate of sulphur that forms to blot out a cross drawn on a piece of paper.

**Learning outcomes**

These are printed on the Student Sheet.

**A suggested approach**

The effect of change of temperature on reaction rate is an everyday experience. Ask students to consider cooking ingredients to make a cake or the way that milk rapidly goes sour if it is not kept cold. When introducing this experiment, students will better understand the procedure if you demonstrate. The experiment can be used as an introduction to collision theory and there is a little about this in the 'Background information' on the Student Sheet. It can also lead to a discussion of the Boltzmann distribution.

The equation for the reaction is:

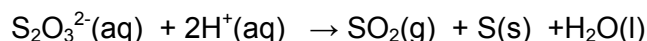

This is also a useful practical for emphasising graph-drawing skills such as choice of scale and line of best fit.

**Technical information**

Requirements per student/group:

Thermometer,  $-10^\circ\text{C}$  to  $110^\circ\text{C}$

250 cm<sup>3</sup> conical flask

2 x 10 cm<sup>3</sup> measuring cylinders

25 cm<sup>3</sup> or 50 cm<sup>3</sup> measuring cylinder

2 mol dm<sup>-3</sup> hydrochloric acid, approximately 25 cm<sup>3</sup> (**irritant**)

40 g dm<sup>-3</sup> sodium thiosulphate, approximately 50 cm<sup>3</sup>

Bunsen burner, tripod, gauze and heatproof mat

**Safety**

The main points are included on the Student Sheet but it is the teacher's responsibility to ensure that a full risk assessment is carried out prior to the practical session. Sulphur dioxide, which is toxic, is produced in this reaction. A well-ventilated laboratory is essential. You should also warn asthmatics, as it is preferable for them to use a fume cupboard. If there is access to a fume cupboard with a sink, use this to wash away the reaction mixture with plenty of water as soon as the reaction is finished. This is particularly important with solutions at higher temperatures.

**Processing the results**

A curve showing that increase in temperature increases reaction rate, as measured by 1/time, should be obtained.

**Answers to questions on the Student Sheet**

- 1 Expect a prediction that increasing the temperature should increase the rate of reaction, since energy is increased so more particles would have the activation energy and there would be an increase in frequency of collision. A discussion of the Boltzmann distribution curve may be appropriate here.

Appendix 2

- 2 Temperature increases the rate of reaction. It is not a directly proportional relationship. You may wish to inform students that, as a guide, for every 10°C rise in temperature, the rate doubles for reactions that work readily at room temperature.

## Appendix 2

**21. Some redox reactions of halogens and halides – Student Sheet**

In these two experiments you will investigate how the halogen elements react with the different halide ions, chloride, bromide and iodide. You will also observe and explain how concentrated sulphuric acid reacts with halide ions.

**Intended lesson outcomes**

By the end of this practical you should be able to:

- describe the relative reactivity of the halogen elements as oxidising agents;
- describe and explain the reactions of halide ions with concentrated sulphuric acid;
- describe and explain redox processes in terms of electron transfer and/or changes of oxidation number.



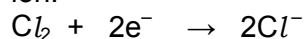

**Experiment 1. Reactions of halogens with halide solutions****Background information**

The Group VII elements are called halogens. They all accept one electron to form a halide ion.

**Questions**

- (a) Write similar half-equations to the one above for bromine and iodine.
- (b) Using ideas of electron gain and loss, explain whether these half-equations are oxidation or reduction reactions.
- (c) Using oxidation numbers, explain whether these are oxidation or reduction half-reactions.

**Safety**

	You must wear eye protection throughout this experiment.
 	Chlorine solution is <b>irritant</b> and <b>liberates a toxic gas</b> . Asthmatics need to be particularly careful. Use of a fume cupboard is advised.
 	Bromine solution is <b>harmful and irritant</b> (use of a fume cupboard is advised), and is <b>dangerous to the environment</b>

**Procedure**

You have three halogen solutions, chlorine water, bromine water and iodine water. You also have test tubes containing potassium chloride, potassium bromide and potassium iodide.

1. Place a piece of universal indicator paper on a white tile.

## Appendix 2

- Use a glass stirring rod to transfer a few drops of the first halogen solution in the table below onto the indicator paper and repeat with fresh paper for the other two solutions. Record your results in the table.
- Add some chlorine solution separately to test tubes containing solutions of potassium bromide and potassium iodide. Record your observations in the table below.
- Now mix solutions of bromine with potassium chloride and potassium iodide solutions and fill in the next row of the table.
- Repeat using mixtures of iodine solution and potassium chloride and potassium bromide. Record your results in the table.

	<i>effect on indicator paper</i>	<i>reaction with potassium chloride solution</i>	<i>reaction with potassium bromide solution</i>	<i>reaction with potassium iodide solution</i>
<i>chlorine water</i>				
<i>bromine water</i>				
<i>iodine water</i>				

**Questions**

- Which halogen solution has the greatest effect on the indicator paper?
- Write balanced ionic equations for the reactions that occurred between halogen solutions and halide solutions.
- Which halogen is the strongest oxidising agent and which halogen is the least oxidising?

**Experiment 2. Reactions of solid halides with concentrated sulphuric acid****Background information**

Concentrated sulphuric acid reacts with solid halides to form the corresponding hydrogen halide.

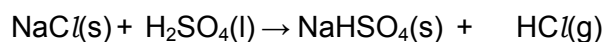

The reaction is complicated by the fact that concentrated sulphuric acid is an oxidising agent. Hydrogen chloride and chloride ions are the most difficult to oxidise and concentrated sulphuric acid is not a strong enough oxidising agent to oxidise them.

Hydrogen bromide and bromide ions are more easily oxidised.

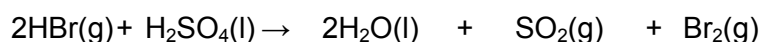
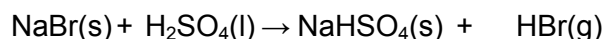



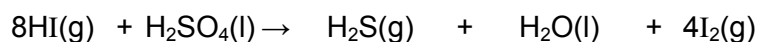



Hydrogen iodide and iodide ions are even more easily oxidised by concentrated sulphuric acid, and sulphur dioxide, iodine and hydrogen sulphide are all produced.



## Appendix 2

## Safety

	You must wear eye protection throughout this experiment.
	Concentrated sulphuric acid is <b>corrosive</b> .
 	Ammonia solution is <b>harmful</b> and <b>dangerous to the environment</b>
 	These reactions <b>liberate harmful and toxic gases</b> . Asthmatics need to be particularly careful. Everyone should use only the very small quantities suggested and avoid inhaling the vapours directly from the tubes.
	Potassium dichromate(VI) is <b>toxic</b> . Do not allow it to come in contact with your skin. Wear gloves when handling filter paper soaked with this solution.

## Procedure

- Put about five sodium chloride crystals in the bottom of a boiling tube and add five drops of concentrated sulphuric acid.
- Test the emerging gas with damp indicator paper and blow across the mouth of the tube. Record your observations.
- Using a glass rod, hold a drop of ammonia solution near the mouth of the tube. Again, record what happens.
- Repeat Step 1 using a few crystals of potassium bromide or potassium iodide. Test the gases coming off firstly with filter paper soaked with potassium dichromate(VI)(aq), which will turn from orange to green in the presence of sulphur dioxide. Write down all the observations you make about these reactions. Look carefully at the 'Background information' to help you identify some of the products.

## Questions

- Write the equation for the production of hydrogen iodide from sodium iodide before it is oxidised.
- What are the oxidation numbers of sulphur and chlorine in the first equation in the 'Background information' for this experiment?
- What changes of oxidation number occur for sulphur and bromine in the third equation in the 'Background information'?
- What changes of oxidation number occur in the last equation in the 'Background information'?
- A yellow solid may also be seen in the reaction with sodium iodide. What substance is this? What does this tell you about the reducing power of iodine?

## Appendix 2

## 21. Some redox reactions of halogens and halides – Teachers' Notes

These two experiments set the scene for understanding the relative oxidising and reducing powers of the halogens and their halide ions.

### Learning outcomes

These are printed on the Student Sheet.

### A suggested approach

This is a good opportunity to remind students about redox reactions, in terms of change of oxidation numbers. After the 'Background information' to Experiment 1, questions are provided to test their understanding. Following the necessary safety warnings, the students could then carry out the reactions. The first task is to consider the bleaching action of the halogens. This gives a clear indication that chlorine is the most reactive, easily bleaching the indicator paper. You could, as a summary, explain that the other reactions are called displacement reactions. As well as discussing the decrease in oxidising power as you descend Group VII, also mention that the reducing power of the halide ion increases as you go down the group.

Experiment 2 extends the ideas of redox reactions to the various reactions of halide ions with concentrated sulphuric acid, which is an oxidising agent. The 'Background information' to this experiment provides some of the theory behind the observations students will make. You will note that we suggest using very small quantities of the reagents and this should be reinforced prior to the practical work.

### Technical information

Requirements per student/group:

#### **Experiment 1**

Potassium chloride solution ( $0.1 \text{ mol dm}^{-3}$ )\*  
 Potassium bromide solution ( $0.1 \text{ mol dm}^{-3}$ )\*  
 Potassium iodide solution ( $0.1 \text{ mol dm}^{-3}$ )\*  
 Chlorine solution ( $0.05 \text{ mol dm}^{-3}$ )\* (**liberates toxic gas**)  
 Bromine solution ( $0.05 \text{ mol dm}^{-3}$ )\*  
 Iodine solution ( $0.01 \text{ mol dm}^{-3}$ )\*  
 Ammonia solution – e.g.  $2 \text{ mol dm}^{-3}$   
 White tile  
 Universal indicator paper  
 Test tubes  
 Test-tube rack

\*It is not necessary for the concentrations of the above solutions to be highly accurate.

#### **Experiment 2**

Concentrated sulphuric acid  
 A few crystals of sodium chloride, potassium bromide and potassium iodide  
 Filter paper soaked with potassium dichromate(VI) solution  
 Ammonia solution – e.g.  $2 \text{ mol dm}^{-3}$   
 Universal indicator paper  
 Boiling tubes  
 Test-tube rack, able to accommodate boiling tubes

## Appendix 2

**Safety**

The main points are included on the Student Sheet but it is the teacher's responsibility to ensure that a full risk assessment is carried out prior to the practical session. Sulphur dioxide and chlorine gas may be present in some of these reactions and asthmatics should be particularly careful not to inhale the vapours. A well-ventilated laboratory is essential. With iodine and concentrated sulphuric acid, some hydrogen sulphide is produced, which is toxic. Use of a fume cupboard is advisable.

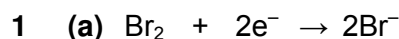
**Answers to questions on the Student Sheet**

(b) These are reduction half-reactions as electrons are gained.

(c) In both cases, the elements have an oxidation number of zero and this changes to  $-1$ . As there is a decrease in oxidation number, these are reduction half-reactions.

2 Chlorine.



4 Chlorine is the strongest oxidising agent as it oxidises bromide and iodide to their respective halogens.

Iodine is the least oxidising agent because it will not oxidise bromide or chloride.

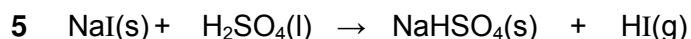

6 They do not change.

7 Bromine changes from  $-1$  to  $0$ .

Sulphur changes from  $+6$  to  $+4$ .

8 Iodine changes from  $-1$  to  $0$ .

Sulphur changes from  $+6$  in sulphuric acid to  $-2$  in hydrogen sulphide.

9 The yellow solid is sulphur.

Iodine is the most powerful reducing agent out of the three halogens used.

## Appendix 2

**25. Cracking hydrocarbons – Student Sheet**

This experiment introduces you to the industrially important cracking reactions. Without them we would not be able to produce many of the organic chemicals on which we rely. We would also not be able to use most of the larger hydrocarbon molecules in crude oil.

**Intended lesson outcomes**

By the end of this practical you should:





- understand the importance of cracking large hydrocarbon molecules to produce more useful alkanes and alkenes of smaller  $M_r$ ;
- have continued to develop manipulative and observational skills.

**Background information**

The demand for petrol is greater than the amount produced by distilling crude oil. Large hydrocarbon molecules do not have much commercial use and these can be cracked to produce smaller molecules that can be converted into petrol. The other molecules that are produced in this reaction are hydrocarbon molecules called alkenes. These are very important in the synthesis of thousands of organic chemicals on which the world relies. The smallest alkene molecule is ethene and this is likely to be one of the alkenes present following a cracking reaction.

The cracking reaction you are going to perform uses a catalyst. The catalyst is able to hold hydrocarbon molecules on its surface until they are literally shaken apart as the C-C bonds break.

**Safety**

	You must wear eye protection throughout this experiment.
	Bromine water is <b>harmful and irritant</b> .
	Dilute, acidified aqueous potassium manganate(VII) is <b>harmful</b>
	and <b>oxidising</b>
	and <b>dangerous to the environment</b> .

Do not allow the water to suck back or the hot test tube will shatter. Using a Bunsen valve makes suck-back less likely.

**Procedure**

1. Add a depth of 2 cm of liquid alkane to a test tube and gently push down some mineral fibre using a stirring rod, allowing the complete absorption of the alkane.
2. Set up the apparatus as shown in Fig. 25.1.



## Appendix 2

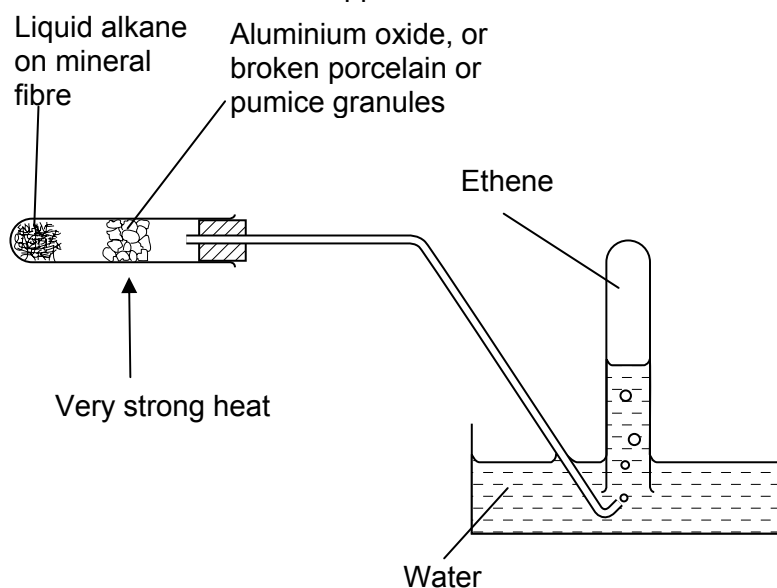

Figure 25.1

3. Heat the aluminium oxide (or broken porcelain/pumice granules) strongly for a few minutes, but be careful not to melt the rubber bung. Just flick the Bunsen flame onto the mineral fibre to ensure you collect a steady stream of bubbles.
4. Discard the first test tube of gas collected, then fill three test tubes with the gas coming off and stopper them.
5. As soon as the number of bubbles slows down, remove the apparatus from the water to avoid water being sucked up the delivery tube and cracking the hot test tube.
6. Carry out the following tests and record your results:
  - (a) What does the gas look like?
  - (b) What does the gas smell like?
  - (c) Use a lighted spill to see if the gas burns.
  - (d) Add two or three drops of dilute, aqueous bromine (the colour should be pale yellow) and shake. What do you observe?
  - (e) Add two drops of very dilute (pale pink), acidified potassium manganate(VII). Note the change of colour.

**Questions**

- 1 Why do you need to discard the first test tube of gas collected?
- 2 Does the gaseous alkene product have the same properties as alkanes?

## Appendix 2

**25. Cracking hydrocarbons – Teachers' Notes**

This experiment introduces students to the industrially important cracking of hydrocarbons to produce smaller alkanes and alkenes.

**Learning outcomes**

These are printed on the Student Sheet.

**A suggested approach**

Explain that crude oil is a mixture of many hydrocarbons. The gasoline fraction is used for petrol but the gasoline fraction on its own is not enough. Typically about 40% of the output of a distillation column may be required as petrol and this is why heavier fractions containing larger hydrocarbon molecules are cracked.

Students do not require foreknowledge of the properties of alkenes and this is a good linking experiment to the properties of alkanes.

**Technical information**

Requirements per student/group:

Liquid paraffin or decane

Bromine water ( $0.04 \text{ mol dm}^{-3}$ )\* **(harmful and irritant)**

Very dilute, acidified potassium manganate(VII) solution –  $\text{KMnO}_4(\text{aq})$   $0.001 \text{ mol dm}^{-3**}$   
**(harmful and oxidising)**

Aluminium oxide granules, or broken porcelain chips or pumice granules

Hard glass test tube or hard glass boiling tube

Delivery tube with bung, preferably fitted with a Bunsen valve (see below)

Three test tubes to collect the gas

Trough or bowl

\*The concentration does not have to be accurate but the solution should be a pale yellow colour.

\*\* The concentration does not have to be accurate but the solution should be a pale pink colour.

**Safety**

The main points are included on the Student Sheet but it is the teacher's responsibility to ensure that a full risk assessment is carried out prior to the practical session. MSDS sheets should be consulted so that the correct action can be taken in event of a spillage and/or accident.

A Bunsen valve can be fitted onto the end of the delivery tube (Fig. 25.2).

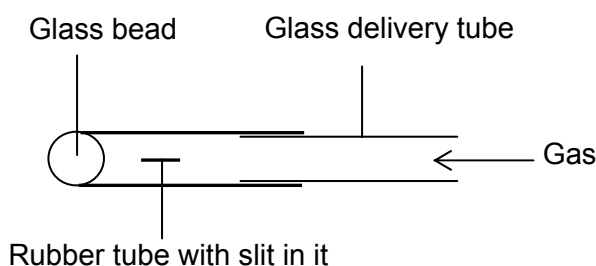

**Figure 25.2** A Bunsen valve

Appendix 2

Gas passes through the slit from the inside into the collection tube, but if the pressure drops inside the delivery tube, the sides of the slit are pushed together so water cannot enter. However, even with a Bunsen valve fitted, suck-back can still occur so always warn students to remove the delivery tube from the water if the rate of production of bubbles slows.

Keep checking that melted bungs do not block the delivery tube as an explosion could occur.

**Answers to questions on the Student Sheet**

- 1 The first test tube will contain mostly air.
- 2 The appearance is a colourless gas but the reaction with bromine water is an instant decolourisation due to the presence of the double bond.

## Appendix 2

**28. Some reactions of alcohols – Student Sheet**













In these experiments you will be introduced to some of the reactions of the alcohol functional group.

**Intended lesson outcomes**

By the end of this practical you should be able to recall the:

- combustion reaction of alcohols;
- reaction of alcohols with sodium;
- oxidation of ethanol to ethanal and ethanoic acid;
- dehydration of alcohols to alkenes;
- reaction of alcohols with carboxylic acids to form esters.

**Safety**

	<b>You must wear eye protection throughout these experiments.</b>
	Alcohols are <b>highly flammable</b> .
	Sodium is <b>corrosive</b> ,
	<b>highly flammable</b> , and undergoes a <b>violent reaction with water</b> .
	Fumes from burning sodium are <b>highly irritant</b> .
	Sodium dichromate(VI) is <b>highly toxic</b>
	<b>and irritant</b> .
	Dilute sulphuric acid ( $1 \text{ mol dm}^{-3}$ ) is <b>irritant</b> . Bromine water is <b>harmful</b> and <b>irritant</b> .
	Dilute, acidified aqueous potassium manganate(VII) is <b>harmful</b>
	and <b>oxidising</b>
	and <b>dangerous to the environment</b>
	Concentrated sulphuric acid and glacial ethanoic acid are <b>corrosive</b> .

## Appendix 2

**Experiment 1. Combustion**

Place about 1 cm<sup>3</sup> of ethanol on a watch glass and ignite with a lighted spill. Record your observations.

**Question**

- 1 Write an equation for this reaction.

**Experiment 2. Reaction with sodium**

Put 1 cm<sup>3</sup> of ethanol in an evaporating basin. Add to this a very small piece of sodium, the size of a rice grain. Record what you observe. Take great care not to allow sodium to come into contact with any water. Ensure all the sodium has reacted before you wash out the evaporating basin.

**Questions**

- 2 (a) The gas that comes off from this reaction is hydrogen and the other product is sodium ethoxide (C<sub>2</sub>H<sub>5</sub>O<sup>-</sup>Na<sup>+</sup>). Write a balanced equation for the reaction of sodium with ethanol.
- (b) Write an equation for the reaction of sodium with water.

**Experiment 3. Oxidation of ethanol**

Put 3 cm<sup>3</sup> of dilute sulphuric acid in a boiling tube and add a few drops of sodium dichromate(VI) solution. Add five drops of ethanol. Heat the mixture very gently until it just boils. Cautiously note the smell. Also record any colour change.

The experiment can be repeated with propan-2-ol and 2-methylpropan-2-ol.

**Questions**

- 3 (a) What does the colour of the solution suggest about what has happened to the dichromate(VI) ion?
- (b) The new organic compound produced by heating ethanol is ethanal. The ethanal can be oxidised further to ethanoic acid. In the experiment you have done, this did not happen because the ethanal boiled off as soon as it was produced. What apparatus could be used to ensure the ethanal stays in contact with the oxidising agent?

**Experiment 4. Dehydration of ethanol**

1. Put ethanol in a test tube to a depth of 2 cm.
2. Use a stirring rod to push in some ceramic fibre, so as to soak up the ethanol.
3. Add aluminium oxide granules to the middle of the tube.
4. Heat the aluminium oxide strongly. Very occasionally, flick the flame onto the ceramic fibre, but only enough to ensure a steady stream of bubbles (figure 28.2).

## Appendix 2

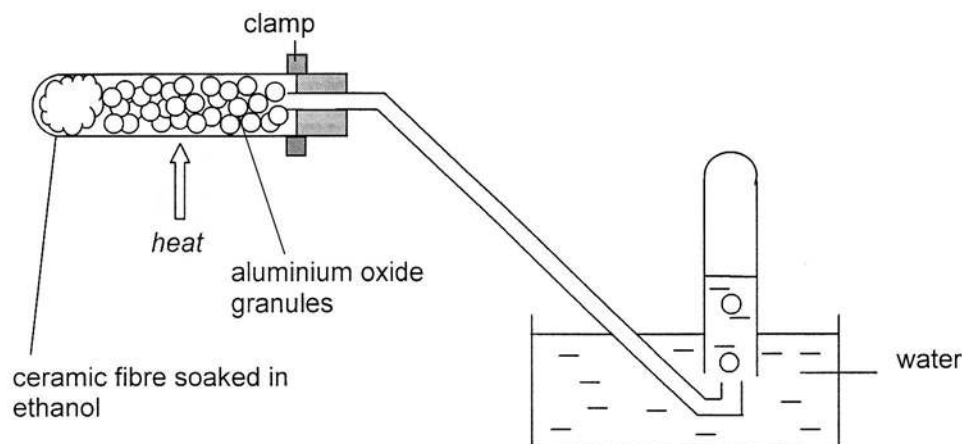

Figure 28.2

5. Discard the first test tube of gas collected and then collect three tubes of gas. Seal each with a bung.
6. Lift the whole apparatus out of the water to avoid suck-back as soon as you stop heating.
7. Light one tube of gas and record your observation.
8. Add two drops of dilute (pale yellow) bromine water to the second tube and shake gently. Record what you see.
9. Add two drops of very dilute (pale pink), acidified potassium manganate(VII). Note the change of colour.

**Questions**

- 4 (a) Why is the first test tube of gas discarded?
- (b) What is the identity of the gas tested?
- (c) Write an equation for the dehydration of ethanol.

**Experiment 5. Ester formation**

In a test tube, make a mixture of 10 drops of ethanol, 5 drops of glacial ethanoic acid and 3 drops of concentrated sulphuric acid. Put hot (recently boiled) water into a 250 cm<sup>3</sup> beaker and warm the mixture for 5 minutes. Pour the liquid into about 20 cm<sup>3</sup> of sodium carbonate solution. This will neutralise any remaining acid and allow you to smell the sweet aroma produced by the ester.

**Question**

- 5 The ester produced is ethyl ethanoate (CH<sub>3</sub>COOC<sub>2</sub>H<sub>5</sub>) and the formula for ethanoic acid is CH<sub>3</sub>COOH. Write a balanced equation for this esterification reaction.

## Appendix 2

**28. Some reactions of alcohols – Teachers' Notes**

These experiments introduce students to some reactions of the alcohol functional group.

**Learning outcomes**

These are printed on the Student Sheet.

**A suggested approach**

Ensure at the outset that students understand that they are going to do five experiments that are potentially hazardous. Take them through the various hazards associated with each of the compounds they are going to use. The experiments are perfectly safe if instructions are followed carefully and if students stick to the volumes suggested.

The questions on the Student Sheet are designed to make students consider the reactions that they observe. The practical session could be followed by a theory lesson explaining what they have observed.

**Technical information**

Requirements per student/group:

Ethanol

Sodium (the size of a rice grain)

Sodium dichromate(VI)  $0.1 \text{ mol dm}^{-3}$

Dilute sulphuric acid ( $1 \text{ mol dm}^{-3}$ )

If desired, propan-2-ol and 2-methylpropan-2-ol

Aluminium oxide granules – 10 g

Ceramic fibre

Bromine water ( $0.04 \text{ mol dm}^{-3}$ )\*

Very dilute, acidified potassium manganate(VII) solution –  $\text{KMnO}_4(\text{aq})$   $0.001 \text{ mol dm}^{-3**}$

**(harmful and oxidising)**

Concentrated sulphuric acid

Glacial ethanoic acid

Sodium carbonate solution – a spatula measure in  $20 \text{ cm}^3$  water

Supply of hot (recently boiled) water for water baths

Evaporating basin

Dropper pipettes

$250 \text{ cm}^3$  beaker

$100 \text{ cm}^3$  beaker

$10 \text{ cm}^3$  measuring cylinders

Hard glass test tubes

Hard glass boiling tubes

Test-tube rack

Delivery tube with bung, preferably fitted with a Bunsen valve (see below)

\*The concentration does not have to be accurate but the solution should be a pale yellow colour.

\*\* The concentration does not have to be accurate but the solution should be a pale pink colour.

**Safety**

The main points are included on the Student Sheet but it is the teacher's responsibility to ensure that a full risk assessment is carried out prior to the practical session. As for practical 25, using a Bunsen valve minimises the risk of suck-back. However, this can still occur, so always warn students to remove the delivery tube

## Appendix 2

from the water if the rate of production of bubbles slows. Keep checking that melted bungs do not block the delivery tube as an explosion could occur. MSDS sheets should be consulted so that the correct action can be taken in event of a spillage and/or accident.

**Answers to questions on the Student Sheet**

- 1  $\text{C}_2\text{H}_5\text{OH}(\text{l}) + 3\text{O}_2(\text{g}) \rightarrow 2\text{CO}_2(\text{g}) + 3\text{H}_2\text{O}(\text{l})$
- 2 (a)  $2\text{C}_2\text{H}_5\text{OH} + 2\text{Na} \rightarrow \text{C}_2\text{H}_5\text{O}^-\text{Na}^+ + \text{H}_2(\text{g})$   
(b)  $2\text{Na}(\text{s}) + 2\text{H}_2\text{O}(\text{l}) \rightarrow 2\text{NaOH}(\text{aq}) + \text{H}_2(\text{g})$
- 3 (a) The dichromate(VI) ion has been reduced from  $\text{Cr}_2\text{O}_7^{2-}(\text{aq})$  (orange) to  $\text{Cr}^{3+}(\text{aq})$  (green/blue).  
(b) Reflux apparatus, i.e. a condenser fitted to a pear-shaped flask, could be used.
- 4 (a) The first test-tube of gas contains mostly air.  
(b) Ethene.  
(c)  $\text{C}_2\text{H}_5\text{OH} \rightarrow \text{C}_2\text{H}_4 + \text{H}_2\text{O}$
- 5  $\text{CH}_3\text{COOH} + \text{C}_2\text{H}_5\text{OH} \rightarrow \text{CH}_3\text{COOC}_2\text{H}_5 + \text{H}_2\text{O}$



# Teaching A2 Chemistry Practical Skills

**Your attention is drawn to the Risk Assessment section on page 1 of this booklet, and to the hazards indicated in Appendices 1 and 2. While every effort has been made to ensure that appropriate safety indications are given, CIE accepts no responsibility for the safety of these experiments and it is the responsibility of the teacher to carry out a full risk assessment for each experiment undertaken, in accordance with local rules and regulations. Hazard data sheets should be available from your suppliers.**

**Acknowledgements**

Thanks are due to Brian Hildick for writing this booklet.

## Contents

Introduction	1
Risk assessment	1
A2 skills	3
Links to the AS syllabus	3
Extensions to the skills practised at AS level, and new skills to learn	3
Teaching students to plan experiments	4
Teaching students to analyse and evaluate experiments, and to draw conclusions	6
Designing a practical course for the A2 year	8
Appendix 1	10
Appendix 2 – Detailed practical lessons	50
1. Electrochemical cells and chemical change	50
2. Redox experiments	59
5. Determination of the dissociation constant for a weak acid	70
9. Determination of the solubility product of $KIO_4$ and an investigation of the common ion effect	75
13. Experiments with enzymes – the effect of enzyme concentration on reaction rate	82
14. Experiments with enzymes – planning an enzyme concentration vs. rate experiment	87
15. Determination of the order of the reaction between hydrogen peroxide and iodide ions in the presence of sulphuric acid	92
19. The preparation and purification of methyl-3-nitrobenzoate	97
21. Planning an experiment to identify a carbonyl compound	102
24. Making an azo dye	106
25. Planning the preparation and purification of <i>N</i> -phenylethanamide	111
26. The preparation and purification of <i>N</i> -phenylethanamide	115
29. Preparation of poly(pyrrole) (a conducting polymer)	121
31. Separation techniques	126

## Introduction

It is expected that this booklet will be used as a follow-on from, or in parallel to, “Teaching AS Practical Skills” and therefore a full introduction is not included. It is recommended that the introductory material in “Teaching AS Practical Skills” is read before starting a course based on this booklet.

This booklet aims to help you design a well-structured scheme of practical work in order to develop your students’ practical skills and their understanding of theory, as well as preparing them for the exam. The practical skills of planning, analysis and evaluation are assessed as A2 and this booklet is designed to show how these skills can be developed and honed through hands-on practical work much more effectively than through a theoretical treatment of the skills. The skills learned through the experiments suggested in this booklet will provide a good foundation for those wishing to pursue science further as well as for those entering employment.

## Risk assessment

All practical work should be carried out in accordance with the health and safety legislation of the country in which it is done. You should not attempt any activities that conflict with this legislation.

Hands-on practical work can be carried out safely in schools. However, to ensure that it is safe, you must identify the hazards and reduce any associated risks to insignificant levels by adopting suitable control measures. You should carry out these risk assessments for all the activities involved in running practical science classes, including storage of materials, preparatory work undertaken by the teacher and any technical support staff, and practical activities carried out in the classroom, whether demonstrations by the teacher or practical activities undertaken by the students. Such risk assessments should also be carried out in accordance with the health and safety legislation of the country in which you are working.

Risk assessment involves answering two basic questions:

- 1 How likely is it that something will go wrong?** For example, students using a double-sided razor blade to cut up carrots are quite likely to cut themselves.
- 2 How serious would it be if it did go wrong?** For example, the consequences of a spark from an experiment landing in an open bottle of magnesium powder are likely to be serious, and include spraying burning magnesium all over the laboratory, burning many students and setting the laboratory ceiling on fire (this scenario is based on a real accident).

Once you have the answers to these questions, it is possible to plan the practical activity to minimise the risk of an accident occurring and, if it does, to minimise its possible severity. In our first example, this could include cutting up the carrot before giving it to young students or providing older students with an appropriate sharp knife rather than a razor blade; in the second, it could include bringing only the amount of magnesium powder required for the activity into the laboratory.

The likelihood that something will go wrong depends on who is carrying out the activity and what sort of training and experience they have had. Obviously you would not ask 11-year-old students to heat concentrated sulphuric acid with sodium bromide or to transfer *Bacillus subtilis* cultures from one Petri dish to another, simply because their inexperience and lack of practical skills would make a serious accident all too likely. However, by the time they reach post-16, they should have acquired the skills and maturity to carry such activities out safely.

Decisions need to be made as to whether an activity should only be carried out as a teacher demonstration or whether it could be performed by students. Clearly, some experiments should normally only be done as a teacher demonstration or by older students. Well-motivated and able students may be able to carry out such an experiment at a younger age,

but any deviation from the model risk assessment needs to be discussed and a written justification must be prepared beforehand.

There are some activities that are intrinsically dangerous and, if included in the suggested procedure, should always be changed to include safer modes of practice. For example, there are **no** circumstances under which mouth pipetting is acceptable – pipette fillers of some sort should **always** be used.

Teachers tend to think of eye protection as the main control measure for preventing injury. In fact, personal protective equipment, such as goggles or safety spectacles, is meant to protect from the unexpected. If you expect a problem, more stringent controls are needed. A range of control measures may be adopted, the following being the most common. Use:

- a less hazardous (substitute) chemical;
- as small a quantity as possible;
- as low a concentration as possible;
- a fume cupboard; and
- safety screens (more than one is usually needed, to protect both teacher and students).

The importance of using the lowest possible concentrations is not always appreciated, but the following examples, showing the hazard classification of a range of common solutions, should make the point.

ammonia (aqueous)	irritant if $\geq 3 \text{ mol dm}^{-3}$	corrosive if $\geq 6 \text{ mol dm}^{-3}$
sodium hydroxide	irritant if $\geq 0.05 \text{ mol dm}^{-3}$	corrosive if $\geq 0.5 \text{ mol dm}^{-3}$
hydrochloric acid	irritant if $\geq 2 \text{ mol dm}^{-3}$	corrosive if $\geq 6.5 \text{ mol dm}^{-3}$
nitric acid	irritant if $\geq 0.1 \text{ mol dm}^{-3}$	corrosive if $\geq 0.5 \text{ mol dm}^{-3}$
sulphuric acid	irritant if $\geq 0.5 \text{ mol dm}^{-3}$	corrosive if $\geq 1.5 \text{ mol dm}^{-3}$
barium chloride	harmful if $\geq 0.02 \text{ mol dm}^{-3}$	toxic if $\geq 0.2 \text{ mol dm}^{-3}$ (or if solid)

Reference to the above table shows, therefore, that if sodium hydroxide is in common use, it should be more dilute than  $0.5 \text{ mol dm}^{-3}$ . Using more concentrated solutions requires measures to be taken to reduce the potential risk.

Your risk analysis should consider the hazards associated with the materials you propose to use.

### Eye protection

Clearly students will need to wear eye protection. Undoubtedly, chemical splash goggles give the best protection but students are often reluctant to wear goggles. Safety spectacles give less protection, but may be adequate if nothing classed as corrosive or toxic is in use.

Your risk assessment should not be restricted simply to the materials, procedures and equipment that will be used, but should have a wider remit that covers the time from when the students enter the room until they leave it.

Practical science can be – and should be – fun. It must also be safe. The two are not incompatible.

Further relevant information on health and safety can be obtained from the following publications:

- Safeguards in the School Laboratory*, 10th edition, ASE, 1996
- Topics in Safety*, 2nd edition, ASE, 1988
- Hazards*, CLEAPSS, 1998 (or 1995)
- Laboratory Handbook*, CLEAPSS, 1997
- Safety in Science Education*, DfEE, HMSO, 1996
- Hazardous Chemicals Manual*, SSERC2, 1997

## A2 skills

### Links to the AS syllabus

In many different activities, the skills learned by performing simple tasks are similar, if not identical, to those required for more complex tasks. Progress is made when basic skills and principles are applied to progressively more complex tasks. Without a firm grounding in the basics, however, this progression will be hindered, or may be stopped altogether. A simple story and a PhD thesis will involve quite different vocabularies and contents, and will be targeted at quite different audiences, but both rely on the same rules of grammar if they are to be clearly understood. In a similar manner, the experiments described in the A2 section of this booklet rely, in the main, on the same basic practical skills that were introduced and practised in the AS course. While it will be necessary to develop new skills for some of the A2 exercises, firm mastery of basic AS skills is crucial if the A2 practical course is to be successful. It would be fair to say that the skills learned and developed at AS level are fundamental to the success of the A2 practical course; none are redundant.

As the A2 practical assessment is made by written examination, some students may choose to ignore or deny the relevance of A2 practical work; as a consequence, they will not accept the need to hone and perfect their practical skills. This view must be **robustly opposed**, as a student without a thorough familiarity with practical chemistry will be in a very weak position to plan, analyse or evaluate an experiment. To be successful in the examination room, when sitting Paper 5, students will have to have been successful and hardworking in the laboratory.

### Extensions to the skills practised at AS level, and new skills to learn

There will be new manipulative skills to learn at A2 level and help is provided in the fully written-up exercises in Appendix 2. Before these new skills and techniques are introduced to the students in a lesson, it is important that the teacher practises the exercise. By doing this, the teacher should gain sufficient practical experience of the exercise to be able to offer constructive advice, and to identify likely problems areas.

Some of the solvents and reagents used in these exercises carry significant safety risks; however, this should not be used as an excuse for not performing a given experiment. Providing the teacher is well practised and familiar with the experiment, there is no reason why any of the experiments in Appendix 2 should not be performed safely. It may be decided, as a result of performing a risk analysis, that the experiment would be better performed as a demonstration. Providing all the students are in a position to see clearly, a demonstration can produce effective teaching and learning. However, where it is thought appropriate to do so, the hands-on experience gained by students as they perform an experiment for themselves does significantly enhance the learning process.

The main areas for extension in the A2 course are in Planning, Analysis and Evaluation. While some exercises may offer more opportunities than others to practise these skills formally, whenever possible and appropriate it is in these areas that the focus of an exercise should be directed. Casually asked questions such as 'How would you ....' or 'What would you do if .....' or 'What does this show us about.....', 'Why is this result anomalous?' or 'What would you change to make this work better/give more accurate results?' about a current experiment can generate a classroom discussion that very effectively drives a point home, as it is specific and relevant to the task in hand.

## Teaching students to plan experiments

Planning is arguably one of the most demanding and difficult skills to learn. In order for training in planning skills to be effective, students must develop confidence in their practical abilities. It is not sufficient that they simply learn to follow instructions; they must be able to apply the experience they have gained from earlier exercises in order to visualise the consequences of a given choice on the outcome of their plan. It is therefore essential that they understand the rationale for using particular approaches, pieces of equipment, recording and analysing techniques, rather than simply being trained to perform a given exercise in a particular prescribed way. An appreciation of precision and reliability is essential when choices of measuring equipment are made, and when experimental procedures are worked out. An understanding of the limits of reliability, frequently described as errors, associated with individual pieces of apparatus is fundamental to the successful choice of apparatus for a given task. A similar argument applies to the identification of variables that need to be controlled, and the proposing of suitable measures to control them.

The advantages and limitations of one type of measuring device, control measure or practical approach compared to other possibilities must be understood if the appropriate equipment, approach and quantities are to be used. It cannot be overstressed that students will only be in a position to plan such details successfully with speed and confidence if they have followed a comprehensive course of hands-on practical work in their A2 year.

The writing of a plan divided into clearly defined stages, each of which must be addressed when producing an effective plan. However, given that practical exercises vary widely in their nature and purpose, it would be unwise to assume that there is a standard 'formula', with predetermined stages, to follow when planning an exercise.

The requirements of a quantitative exercise, the purpose of which is to propose and test a hypothesis, or to measure a trend (such as is found in the  $K_a$  plan in Exercise 6, and the enzyme catalysis plan in Exercise 13, in Appendix 2) will be very different to the requirements of a quantitative organic preparation, where the student is required to prepare a plan for the preparation of a given mass of product (as in the preparation of *N*-phenylethanamide plan in Exercise 25 in Appendix 2). The plan for an analytical investigation (as in the identification of carbonyl compounds in Exercise 21 in Appendix 2) will be different again.

Thus, students need to develop a flexible approach to planning, which allows them to tackle a wide range of different types of exercise. To do this they will have to be able to identify and understand the specific requirements of a particular planning exercise and devise for it a tailor-made plan. To reinforce what has been said earlier, this takes time and practice.

### 1 Defining the problem

#### For a quantitative exercise

- Students should be able to use information provided about the aims of the investigation, or experiment, to identify both the independent and the dependent variables. Also, the other key variables must be identified and effective measures proposed to control them.
- They may be required to use their knowledge and understanding of the topic under consideration to make a quantitative prediction of the likely outcome of the experiment.
- The purpose of the plan would then be to test this hypothesis in a manner which is reliable, unambiguous and, above all, reproducible.
- Even if making a formal hypothesis is not a requirement of an exercise, students will still need to have a clear idea of what they expect the results to show if they are to analyse and evaluate their results effectively.

The data obtained in the exercise will then require processing in some way in order to allow for analysis and evaluation.

- The plan must contain details of how these processes are to be carried out.
- If the experiment is to generate quantitative data, then the recording, graphical and numerical processes involved in the data analysis must be clearly laid out.
- The steps by which the analysed data, and the experimental procedure, are to be evaluated should also be described.

### For a qualitative exercise

Examples of this type of planning exercise would be the preparation of a required mass of product in an organic synthesis (see exercise 25) or the devising of an analysis scheme to identify an unknown compound (see exercise 21). Clearly, a different approach is required for such examples to that used to plan a quantitative exercise but students are likely to find them to be just as demanding.

Whatever the type of planning exercise, the plan should be sufficiently robust that, when performed by competent chemists, the outcomes will not vary beyond anticipated limits. Without first-hand experience of the approach and procedures to be used, it is highly likely that the plan will be flawed.

## 2 Methods

The proposed experimental procedure should be workable. It should, given that the apparatus is assembled appropriately, allow data to be collected without undue difficulty. There should be a description, including diagrams, of how the experiment should be performed and how the key variables are to be controlled. Equipment, of a level of precision appropriate for the measurements to be made, and quantities to be used should be specified. The use of control experiments should be considered. Also, details of how the data are to be recorded, manipulated, analysed and evaluated should be given (see point 3 below).

Aspects of the planning process which students frequently find difficult are deciding on a suitable scale for the experiment and choosing suitable apparatus. It is suggested that the teacher frequently asks questions such as 'why do we use this amount of solid?' or why do we choose this volume of liquid?' when students are following an experiment from a worksheet, rather than allowing them to blindly follow a recipe. Similarly, the choice of apparatus should be questioned. By doing this, students will gain experience in these areas and so be better prepared when they have to make such decisions for themselves. In some cases, the choice of volume or apparatus will have a significant influence on the precision and reliability of an experiment. Exercise 9 requires students to consider the effect of the inherent error in a burette measurement on the overall reliability of a titration exercise as small and large volumes are measured from the burette. Such knowledge is of great value when choosing suitable volumes in a planning exercise.

It is often in the fine detail that students tend to let themselves down. Many students will be able to produce a broad overview of what is to be done but it is likely that far fewer will produce a plan sufficiently detailed for it to be successfully used by their peers.

Exercise 6 incorporates several different planning tasks. Firstly, students are required to plan how a pH curve for the titration might be obtained, and they are asked to predict the shape of this curve. Performing their planned titration exercise would then allow this hypothesis to be tested. To be effective, this part of the plan must contain sufficient detail, in terms of quantities, the number and range of measurements and the means by which the results will be used to draw the pH curve, to allow an experienced chemist to perform the task. Students must then plan how they are to deduce the  $pK_a$  value for the acid using their pH curve. Finally, the plan must describe how the required buffer solution is to be prepared, and how its effectiveness as a buffer is to be tested. This latter part of the plan provides a significant test of a student's understanding of buffer theory and so is likely to reveal problem areas.

In Exercise 25, students are provided with sufficient background information regarding the chemistry involved in the organic preparation so that no previous experience of this particular preparation is needed. What students do need, however, is experience of the various



processes involved in the preparation; together with experience in mole and percentage yield calculations. Students who have sound practical skills and who are experienced in measuring volumes, filtration, recrystallisation and melting point determination will find the exercise to be straightforward. Those students who lack familiarity with such processes will struggle.

The approach to planning required in Exercise 21 is very different to the approaches employed above. In this exercise, students must identify the different types of carbonyl compounds given in the question, decide how they differ in their chemical properties, select suitable chemical tests to allow them to be distinguished from each other and then produce a logical sequence for these tests. Finally, students must be able to demonstrate their understanding of the part played in the characterisation of a compound by the preparation of derivatives, and the use of spectroscopic analytical techniques. The exercise provides a sound test of the chemistry involved but it also effectively tests communication skills.

Whichever type of planning exercise a student undertakes it is important, both for the safety of the student and also for the safety of those around, that a realistic risk assessment is made as part of the plan. By requiring students to focus on the risks in advance of the practical class, they will gain experience in this area and so will be less likely to take risks in the practical class.

### **3 Analysis, conclusions and evaluation**

Consideration should be given in the plan of how the data obtained in an experiment are to be analysed, interpreted and evaluated. Valid and reliable conclusions can be drawn only if the strategies devised to address these points are effective. This may involve the generation of a results table and the use of graphical techniques, as in Exercise 6, the determination of yield and purity in a preparative experiment such as Exercise 25 or the devising of a logical framework for deciding on the identity of an unknown sample, such as in Exercise 21. Again, the wide range of possible planning topics requires students to show flexibility, and perhaps even ingenuity, in their response to planning tasks.

## **Teaching students to analyse and evaluate experiments, and to draw conclusions**

### **1 Analysing data**

This skill requires students to apply their understanding of underlying theory. Even when that understanding is present, however, many students still struggle. The presentation of a clear, lucid, watertight argument does not come naturally to most people and therefore much practice in this area is recommended.

Any conclusion made on the basis of data obtained from an experiment must be fully reasoned and justified. This justification may take the form of a written argument, for example in the interpretation of the results of a series of tests designed to determine the identity of an unknown compound, as in Exercise 21. It may take the form of an extended calculation, as would be required in the determination of the Avogadro constant in Exercise 3 or it may involve graphical steps, as in rate order determinations in Exercise 15.

The steps followed as an argument is developed, must be sequential, clear and easy to follow. In the examinations, students will have to convince a stranger that their reasoning is sound. The plea 'well you know what I meant' might convince a teacher who is familiar with that student's work, but will not convince an external examiner.

To confidently analyse numerical data, students must be both proficient in handling the mathematics involved and experienced in the calculation sequence involved. Similarly, students will struggle with, for example, inorganic or organic analysis experiments if their theoretical knowledge is weak. Therefore, it follows that success in the practical class will depend to an extent on success in the theory class.

Students should be aware that the number of significant figures to which the answer is expressed shows the precision of a measured quantity. Therefore, great care should be taken with regard to the number of significant figures quoted in an answer. The general rule is to use the same number of significant figures as are found in the least precisely measured quantity.

Another skill which many students find difficult to master is that of error analysis. Students need to be familiar with two types of 'error'. The first type of 'error' is that which is inherent in the use of a particular piece of equipment/apparatus. Although we refer to this as an apparatus error, we really mean that there is a 'range of uncertainty' associated with measurements made with that piece of apparatus. This uncertainty will be present no matter how skilled the operator might be.

The second type of error is appropriately called experimental error and is a direct consequence of the level of incompetence of the operator or of flaws in the experimental procedure. If the overall experimental error, as measured against a reliable benchmark, is greater than the combined apparatus errors, students should look for flaws in technique or experimental procedure.

One of the aims of exercise 9 is to help students to focus on this point by requiring them to compare the error in burette measurements when the same burette is used to measure volumes of  $100 \text{ cm}^3$  and  $5 \text{ cm}^3$ . Clearly, the error, or uncertainty, in measuring the  $5 \text{ cm}^3$  volume will be twenty times that when  $100 \text{ cm}^3$  is measured.

## 2 Evaluation

Arguably, this is one of the most important, and probably one of the most difficult, skills to acquire. In order for an evaluation to be effective, students must have a clear understanding of the aims, objectives and predicted outcomes of the exercise. Without such knowledge they will be in no position to judge the effectiveness of the procedures used.

The evaluation procedure may include:

- (i) the identification of anomalous values, deducing possible causes of these anomalies and suggesting appropriate means of avoiding them.
- (ii) the adequacy of the range of data obtained.
- (iii) the effectiveness of the measures taken to control variables.
- (iv) an informed judgement on the confidence with which conclusions may be drawn.

Anomalous results are those which do not fit in with the pattern formed by the other results of an experiment. If such results are to be identified, the expected pattern must be known. This pattern could be predicted as part of a hypothesis or deduced from the clear trend shown by the remaining results. However, when the anomalous value is identified, the selection of this value must be supported by evidence. Once an anomalous value has been identified, it is necessary for students to attempt to explain the origin of the anomaly and to propose strategies to deal with it. These strategies might include repeating the measurement or omitting it.

In experiments such as the  $K_a$  determination in Exercise 6, once the pH curve has been plotted, it may become clear that the experiment has not provided sufficient data in some parts of the curve. Thus, the number measurements taken and/or the range of measurements taken were not adequate. When evaluating such an experiment, it would be sensible to propose the inclusion of extra measurements to clarify and to specify where these extra measurements should be made.

When the results of a quantitative experiment are known to be clearly inaccurate, the results should be evaluated. Students must be able to deduce whether the errors in the data obtained in an experiment exceed those expected due to the apparatus used.

If the errors in the data do exceed the apparatus errors, then flaws in the procedure that have generated these excess errors must be identified. Having identified potential flaws, students must have sufficient knowledge of the process involved, that they are able to suggest changes to the procedure that will result in a more accurate or reliable outcome. If the perceived flaw lies, for example, with temperature fluctuation, it would be of little use to simply state that the temperature should be controlled. What is needed is a practical solution to this problem, such as the use of a thermostatically-controlled water bath.

If the errors in the data do not exceed those expected due to the apparatus used, then improvements to accuracy would be achieved by changing the apparatus used. If, for example, the perceived flaw lies with the precision of a mass measurement, rather than a vague reference to the use of a 'more precise balance', the precision of the replacement balance to be used should be specified, for example, 'a balance weighing to  $\pm 0.01$  g'.

For conclusions to be drawn on the basis of the results of an experiment, it is essential that the results of the experiment inspire confidence. Simple statements by students to the effect that they are happy with their results and that their experiments worked may well be true but they are of little value and will earn no credit. If an experiment worked well, it is necessary that this judgement be supported by evidence from the experimental results.

### 3 Drawing conclusions

This is also a higher-level skill, which will demand of the student a thorough understanding of the basic theory that underpins the chemistry involved.

The conclusions drawn from a set of data must be judged on the basis of the strength or weakness of any support for or against the original hypothesis or on the results of qualitative tests. Students should be able to use the detailed scientific knowledge and understanding they have gained in theory classes in order to make judgements about the validity of the conclusions they have drawn.

Without practice in this area, students are likely to struggle. In order to increase the confidence of students in drawing conclusions, it is recommended that exercises which are set within familiar contexts are used initially. Once confidence has started to grow, then is the time to move to less familiar territory.

## Designing a practical course for the A2 year

The course outlined in Appendix 1 is based simply on syllabus order. It is highly likely that the schemes of work used by different teachers will require topics to be taught in very different sequences. This is fine, as there is no preferred order for performing these practical exercises.

What is important, however, is that your students see the relevance of their practical lessons and that their skills are developed gradually, starting with simple exercises and moving on to more advanced activities. Most of the exercises are designed to provide practical support to the teaching which goes on in theory lessons. Careful scheduling of experiments so that they fit into the normal teaching programme will reinforce the essential nature of practical chemistry. The extra input to the learning process provided by a well-run and successful practical lesson is well worth the effort involved in preparing it.

As the Paper 5 examination approaches it will become necessary to increase the emphasis placed on planning, analysis and evaluation skills. However, it is vital that you introduce these skills right from the beginning of the A2 course, as this allows time for these skills to develop and mature.

Appendix 1 contains thirty-two exercises, fourteen of which have been fully worked up in Appendix 2. Of these fourteen, several contain suites of experiments. Apart from providing 'Student Sheets' and 'Teachers' Notes' the purpose of the fully written up exercises is to provide ideas as to how you may use the remaining exercises in Appendix 1. The intention is

not to be prescriptive. An approach or exercise that works well in one institution may well be less successful in another. What is important is that when you have used a practical exercise, you evaluate its effectiveness. On the basis of such evaluations, your practical programme will evolve.

## Appendix 1

## Appendix 1

Syllabus section	Skills/Learning Outcomes	Notes	Sources
6f, 6g, 6i	<b>1. Electrochemical cells</b>		
	<ul style="list-style-type: none"> <li>Set up an electrochemical cell</li> <li>Read a voltmeter</li> <li>Record observations from test tube experiments</li> <li>Compare results from different types of experiment</li> <li>Write cell descriptions and calculate <math>E_{\text{cell}}</math></li> </ul>	<p>Electrochemical cells are constructed and their e.m.f. values measured; these results are compared with the equivalent test-tube reactions. The effect on the cell e.m.f. of varying solution concentration is investigated. The outcome of a redox reaction is analysed and the feasibility of a reaction is deduced.</p> <p><b>Timing:</b> 1–1.5 hours</p>	<p><b>Appendix 2</b> A similar exercise is to be found in <i>Chemistry in Context</i> – third edition; Hill &amp; Holman</p> <p><b>Practical 11</b></p>
6g	<b>2. Redox experiments</b>		
	<ul style="list-style-type: none"> <li>Record colour changes accurately</li> <li>Decide when to use a control experiment</li> <li>Design tests to assess relative oxidising ability</li> <li>Analyse a set of tabulated results and draw conclusions</li> <li>Tabulate a set of conclusions</li> <li>Write overall ionic equations from redox half equations</li> <li>Deduce order of oxidising ability and the feasibility of reactions</li> </ul>	<p>The exercise is based on a series of test-tube reactions designed to investigate the reactions between various oxidising agents and reducing agents. Careful observations allow deductions to be made regarding the oxidising strengths of a number of different species. Ionic equations are written based on the redox half-equations provided. The feasibility of a reaction is deduced from the provided Standard Electrode Potential data.</p> <p><b>Note:</b> The layout used in this exercise could be adapted for use with other reactants.</p> <p><b>Timing:</b> 1 hour</p>	<p><b>Appendix 2</b></p>

## Appendix 1

Syllabus section	Skills/Learning Outcomes	Notes	Sources
6k, 6m, 6n	<p><b>3. Determining the value of the Avogadro constant by electrolysis</b></p> <ul style="list-style-type: none"> <li>• Consolidate manipulative skills</li> <li>• Make precise measurements of time, current and mass</li> <li>• Analyse data numerically</li> <li>• Compare outcome with data book value and hence determine experimental error</li> <li>• Evaluate experimental procedures and identify potential sources of error</li> <li>• Suggest procedural improvements to reduce/eliminate errors</li> </ul>	<p>The value of the Avogadro constant, <math>A_N</math>, may be determined using an electrolytic method. The apparatus needed, and the general approach is very similar to that used in Experiment 4. You may use your 'usual' electrolysis apparatus, or you may choose to place the two electrodes in separate beakers, joined by a salt bridge made from a glass tube filled with saturated potassium nitrate solution, as in an electrochemical cell. The latter option prevents <math>\text{Cu}^{2+}</math> ions from migrating to the cathode, where they would interfere with the release of hydrogen gas, and so reduce the accuracy of its volume measurement. In both cases, the electrolyte used is <math>0.50 \text{ mol dm}^{-3}</math> sulphuric acid.</p> <p>The electrodes are cleaned by briefly dipping (for 2–3 s) into <math>6 \text{ mol dm}^{-3} \text{ HNO}_3</math>, (<b>care – corrosive</b>) followed by washing (as in Exercise experiment 4). Very precise measurement is needed, so weighing the <b>anode</b> to 4 d.p., or a similarly precise measurement of the volume of hydrogen produced, would be best. The total charge (Coulombs) required to release one mole of copper, or hydrogen, is then calculated. From this, the number of copper atoms in one mole may be deduced (see example below). Evaluate procedure by comparison of result with data book value.</p>	Modified Experiment 4

## Appendix 1

Syllabus section	Skills/Learning Outcomes	Notes	Sources
		Calculation Total charge = current (A) $\times$ time (s) / Coulombs <i>e.g.</i> = $0.601 \times 1802 = 1083$ Coulombs $N^{\circ} e^{-}$ = total charge $\div$ charge per $e^{-}$ <i>e.g.</i> = $1083 \div 1.6022 \times 10^{-19} = 6.759 \times 10^{21} e^{-}$ $N^{\circ} Cu^{2+}$ = $N^{\circ} e^{-} \div 2$ <i>e.g.</i> = $6.759 \times 10^{21} \div 2 = 3.380 \times 10^{21} (Cu^{2+})$ Mass $Cu^{2+}$ ions formed = mass Cu lost <i>e.g.</i> = $0.3554$ g Moles $Cu^{2+}$ = mass $Cu^{2+} \div A_r(Cu)$ <i>e.g.</i> = $0.3554 \div 63.546 = 5.593 \times 10^{-3}$ mol $N^{\circ} Cu^{2+}/mol$ = $N^{\circ} Cu^{2+}$ ions $\div$ moles $Cu^{2+}$ ions <i>e.g.</i> $A_N$ = $3.380 \times 10^{21} \div 5.593 \times 10^{-3}$ = $6.044 \times 10^{23}$ The Avogadro constant = $6.04 \times 10^{23}$ $\% \text{ error}$ = $\frac{6.04 \times 10^{23} - 6.02 \times 10^{23}}{6.02 \times 10^{23}} \times 100$ = $0.332\%$ Timing: 1 hour	

## Appendix 1

Syllabus section	Skills/Learning Outcomes	Notes	Sources
6m	<p><b>4. Quantitative electrolysis</b></p> <ul style="list-style-type: none"> <li>• Consolidate manipulative skills</li> <li>• Make measurements of time, current and mass</li> <li>• Analyse data numerically</li> <li>• Compare outcome with data book value and hence determine experimental error</li> <li>• Evaluate experimental procedures and identify potential sources of error</li> <li>• Suggest procedural improvements to reduce/eliminate errors</li> </ul>	<p>Set up the circuit as for an electrolysis experiment, using a 6 V d.c. supply, a milliammeter (range 0–1 A), a variable resistor, two copper electrodes and an electrolysis cell (containing 0.10 mol dm<sup>-3</sup> aqueous copper(II) sulphate). <b>(Harmful, Harmful to the environment)</b></p> <p>Clean the electrodes with emery paper, wash the <b>anode</b> with water and then with methanol, <b>(Toxic, Highly flammable)</b> dry and weigh it accurately (to at least 3 d.p.). Partially immerse the electrodes in the copper sulphate solution and pass a current of about 0.4 A for about 30 min. Measure both the time and the current with <b>precision</b>. Remove the <b>anode</b>, wash it with water and then with methanol, dry it and reweigh it.</p> <ol style="list-style-type: none"> <li>1. From the loss in mass of the anode, deduce the mass and moles of copper lost.</li> <li>2. From the current and time, calculate the charge which flowed though the circuit using: charge (Coulombs) = current (A) × time (s).</li> </ol> <p>Using the answers to <b>1</b> and <b>2</b>, calculate the number of Coulombs needed to remove one mole of copper.</p> <p>A charge of 193000 (2 × 96500) Coulombs is required to remove one mole of copper. The difference between this and the value above is a measure of experimental error. Calculate this error as a percentage of the accurate value (193000 Coulombs). Sources of error should be identified and suggestions made to limit/eradicate them.</p> <p><b>Timing:</b> 1 hour</p>	<p><i>Classic Chemistry Experiments</i>, The Royal Society of Chemistry – Experiment 81</p>



## Appendix 1

Syllabus section	Skills/Learning Outcomes	Notes	Sources
7j, 7k	<p><b>5. Determination of the dissociation constant for a weak acid without pH meter</b></p> <ul style="list-style-type: none"> <li>• Use a pipette and a burette to produce solutions of different concentration</li> <li>• Prepare a buffer solution</li> <li>• Use and understand indicator theory</li> <li>• Calculate dissociation constants</li> </ul>	<p>This experiment allows the colour of a bromocresol solution at different pH values to be investigated by viewing the combined colour of two solutions, one solution having the [HIn] at a given pH and the other solution having the [In<sup>-</sup>] present at that pH. A number of combinations of solutions, covering a range of pH values, are prepared and the pH of a solution of a weak acid (containing bromocresol) is to be established by colour comparison. From this, the <math>K_a</math> value of the acid may be calculated</p> <p><b>Timing:</b> 1 hour</p> <p><b>Note:</b> More interesting than using universal indicator. Explores indicator theory.</p>	<b>Appendix 2</b>

Syllabus section	Skills/Learning Outcomes	Notes	Sources
7j, 7k, 7l, 7m	<p><b>6. Measuring the <math>K_a</math> value of a weak acid (PLANNING)</b></p> <ul style="list-style-type: none"> <li>Plan a quantitative exercise, considering approach, quantities, precision, apparatus and data analysis</li> <li>Calculate quantities needed to make a buffer solution</li> <li>Devise a system to test the effectiveness of the buffer solution</li> </ul> <p><b>Suggested assessment points</b></p> <ol style="list-style-type: none"> <li><b>Setting up</b> and buffering pH meter/electrode</li> <li><b>Titration:</b> Rinsing pipette and burette; HA in pipette; measures volumes NaOH and pH; records volume – smaller intervals near pH 7; continues adding excess NaOH.</li> <li><b>pH curve:</b> axis/scales/shape correct, fits scales, shows working to get <math>pK_a</math> from <math>V/2</math>.</li> <li><b>Buffer:</b> quotes volumes NaOH/HA to use, volume NaOH = <math>V/2</math>; adds small volume of <b>named</b> strong acid/base to test buffer; uses water as control; measures pH before/after each addition; compares pH change of buffer/control</li> </ol>	<p>In this exercise students plan experiments to find the <math>pK_a</math> value of a weak acid, to prepare a buffer solution using that acid and to test the buffering capacity of their buffer solution.</p> <p><b>Background Information</b></p> <ul style="list-style-type: none"> <li>The weak acid is monobasic and may be represented as HA.</li> <li>When a weak acid is titrated with a strong base then at the half-neutralisation point <math>pK_a = \text{pH}</math> (the pH when half the volume of base required to exactly neutralise the acid has been added to the acid).</li> <li>Start with exactly <math>0.100 \text{ mol dm}^{-3}</math> aqueous sodium hydroxide (<b>Corrosive</b>) and approximately <math>0.100 \text{ mol dm}^{-3}</math> aqueous HA.</li> <li>A buffer solution resists large changes in pH when small amounts of acid or base are added.</li> </ul> <p><b>Plan</b></p> <p>The plans should include the following-</p> <ol style="list-style-type: none"> <li>Full practical detail of the experiments, including the apparatus they would use, and the measurements they would make, from which they could draw a <b>pH curve</b> for the reaction.</li> <li>A sketch of the expected pH curve, which clearly shows how the values of the neutralisation volume, <math>V \text{ cm}^3</math>, and the <math>pK_a</math> values are obtained.</li> <li>A description of how they would prepare a buffer solution by mixing accurately measured volumes of HA and sodium hydroxide. The buffer solution should have a <b>pH equal to the <math>pK_a</math> value</b> of HA.</li> </ol>	<p>Details of similar experiments can be found in many A level practical books.</p>

## Appendix 1

Syllabus section	Skills/Learning Outcomes	Notes	Sources
		<p>Explanation of choice of volumes by making reference to the expressions:</p> $K_a = \frac{[H^+][A^-]}{[HA]} \quad pK_a = \text{pH (at half-neutralisation point)}$ <p>4. A description of the experiments they will carry out to check the buffering capacity of the solution you have prepared. You must compare the changes in pH of your buffer with that of a control.</p> <p><b>Time:</b> 1 hour  <b>Note:</b> Some suggestions for assessment points are given but they may need to be amended or adjusted depending on the experience of the class.</p>	

## Appendix 1

Syllabus section	Skills/Learning Outcomes	Notes	Sources
7j	<p><b>7. Finding <math>K_a</math> for two weak acids</b></p> <ul style="list-style-type: none"> <li>• Use a pipette and a burette with confidence and precision</li> <li>• Calibrate and use a pH meter</li> <li>• Deduce the <math>K_a</math> value of a weak acid from concentration and pH data</li> <li>• Deduce the <math>K_a</math> of a weak acid by graphical means</li> <li>• Evaluate and suggest improvements to the experiments used in the exercise</li> </ul>	<p>In this exercise, students determine the <math>K_a</math> values of two different weak acids. It is not critical which weak acids are used but 0.100 mol dm<sup>-3</sup> solutions of ethanoic acid (<b>Corrosive</b>) and chloroethanoic acid (<b>Toxic, Harmful to the environment</b>) work well. The aqueous sodium hydroxide used in the experiments should have an accurately known concentration of about 0.100 mol dm<sup>-3</sup>.</p> <p>The <math>K_a</math> value of the first acid (HA1) is deduced, in Experiment 1, by first determining the pH and the concentration of the weak acid solution.</p> <p>The <math>K_a</math> value of the second acid (HA2) is deduced, in Experiment 2, by reading the pH value at the <i>half-neutralisation</i> (half-equivalence) point from a pH graph.</p> <p><b>Experiment 1</b> <b>Procedure</b></p> <ol style="list-style-type: none"> <li>1. Set up, buffer and calibrate a pH meter and use it to measure the pH of the weak acid solution, HA1.</li> <li>2. Titrate the weak acid solution against 0.100 mol dm<sup>-3</sup> aqueous sodium hydroxide using phenolphthalein as indicator.</li> </ol> <p>Calculate the <math>K_a</math> value for the weak acid HA1 using the formula: <math>K_a = \frac{[H^+]^2}{[HA]}</math></p> <p><b>Experiment 2</b> <b>Procedure</b></p> <ol style="list-style-type: none"> <li>1. Construct a table to show the volume of aqueous sodium hydroxide added and the pH of the solution. Record the volume and pH data, obtained in the steps which follow, in this table.</li> </ol>	<p>Details of similar experiments can be found in many A level practical books.</p>

## Appendix 1

Syllabus section	Skills/Learning Outcomes	Notes	Sources
		<ol style="list-style-type: none"> <li>2. Transfer 25.00 cm<sup>3</sup> of the solution of the weak acid, HA<sub>2</sub>, to a conical flask. Measure the pH of this solution using a pH meter.</li> <li>3. From a burette, add 5.00 cm<sup>3</sup> of aqueous sodium hydroxide. Stir the mixture and measure its pH.</li> <li>4. Repeat step 3 until the neutralisation point is close. Now add the aqueous sodium hydroxide in smaller quantities as the pH changes rapidly.</li> <li>5. Once the neutralisation point is passed, and the pH is no longer changing rapidly, add 5.00 portions of aqueous sodium hydroxide until a total of about 40.0 cm<sup>3</sup> has been added.</li> <li>6. Plot a graph of pH vs. volume of sodium hydroxide added.</li> <li>7. From your graph read off the volume, <math>V</math> cm<sup>3</sup>, at the neutralisation (equivalence) point.</li> <li>8. Calculate the volume of aqueous sodium hydroxide, <math>V/2</math> cm<sup>3</sup>, required to half neutralise the weak acid solution.</li> <li>9. The <math>pK_a</math> value of HA<sub>2</sub> is equal to the pH value at <math>V/2</math> cm<sup>3</sup>. Read off this value from your graph and from it deduce the <math>K_a</math> value of HA<sub>2</sub>.</li> </ol> <p>Evaluate both experiments and suggest changes which would improve their accuracy.</p> <p><b>Timing:</b> about 1 hour for each experiment</p> <p><b>Note:</b> If a pH meter is not available, the pH values may be determined using Universal Indicator paper. It is strongly suggested that a series of 'narrow range' papers are used, rather than papers which are designed to cover almost the whole of the pH range.</p>	

## Appendix 1

Syllabus section	Skills/Learning Outcomes	Notes	Sources
71	<p><b>8. Making a pH indicator</b></p> <ul style="list-style-type: none"> <li>• Prepare extracts of a variety of coloured plant material</li> <li>• Test the response of these extracts to pH change</li> <li>• In conjunction with the buffer solutions produced in experiment 10, determine the effective range of the indicators present in your extracts</li> </ul>	<p>A pH indicator is a substance that has a different colour when added to acid or alkali. Litmus is an extract of lichens (e.g. <i>Rocella</i>). In this experiment a pH indicator is made from red cabbage or from fresh beetroot, green cabbage or coloured flower petals such as roses or hydrangeas. A number of different extracts should be prepared and their end-point characteristics compared.</p> <p>If this experiment is performed just prior to Exercise 10 (pH Buffers and Indicators), the effective range, as well as the colour change, of each indicator may be found. The indicator extracted from red cabbage is an anthocyanin dye. A literature/internet search for the identities of the indicators present in the other natural materials used might prove to be of interest to some students.</p> <p><b>Procedure</b></p> <ol style="list-style-type: none"> <li>1. Boil 20–30 g of red cabbage in about 100 cm<sup>3</sup> of tap water for about 5 min. The water should have developed a noticeable colour.</li> <li>2. Allow the mixture to cool for a few minutes and filter it.</li> <li>3. Place three test tubes in a rack. Half fill one with alkali, one with acid and one with deionised water.</li> <li>4. To each test tube add approximately 2–3 cm<sup>3</sup> the filtrate.</li> <li>5. What colour is the indicator when neutral, when alkaline and when acidic?</li> <li>6. Repeat steps 1–5 for each of the samples you have been given.</li> </ol> <p><b>Timing:</b> 1 hour</p> <p><b>Note:</b> This is a fun experiment with a message. Many students are unaware of the major role played by natural products in our lives.</p>	<p><i>Classic Chemistry Experiments</i>. The Royal Society of Chemistry – Experiment 38</p>

## Appendix 1

Syllabus section	Skills/Learning Outcomes	Notes	Sources
7p, 7q, 7r	<p><b>9. <math>K_{sp}</math> and the 'common ion effect'</b></p> <ul style="list-style-type: none"> <li>• Make up standard solutions and prepare equilibrium mixtures</li> <li>• Plot a graph</li> <li>• Calculate concentrations and deduce <math>K_{sp}</math> values</li> <li>• Calculate experimental errors and apparatus errors and use these to evaluate experimental accuracy</li> <li>• Consider the implications of apparatus errors when undertaking a planning exercise</li> <li>• Understand the common ion effect</li> </ul>	<p>This experiment explores the common ion effect by measuring the changes in solubility of <math>KIO_4</math> as the concentration of <math>K^+</math> ions is varied. A value for <math>K_{sp}(KIO_4)</math> is obtained. There is a detailed error analysis that compares the inherent apparatus errors when applied to large and small volumes. The exercise invites discussion of the implications of this when choosing equipment and quantities in a planning exercise.</p> <p><b>Timing:</b> 1.5–2 hours</p>	<p><b>Appendix 2</b></p>

## Appendix 1

Syllabus section	Skills/Learning Outcomes	Notes	Sources																																																																								
7l, 7n	<p><b>10. pH Buffers and Indicators</b></p> <ul style="list-style-type: none"> <li>Prepare buffer solutions of known pH values.</li> <li>Determine the effective range and colour changes for a variety of indicators</li> <li>Prepare a universal indicator and investigate its colour changes over a wide pH range</li> <li>Deduce the composition of, and prepare, a buffer solution of given pH value</li> <li>Understand the buffering effect</li> </ul> <table border="1"> <thead> <tr> <th>pH</th> <th>A</th> <th>B</th> <th>pH</th> <th>A</th> <th>B</th> </tr> </thead> <tbody> <tr><td>2.0</td><td>195</td><td>5</td><td>7.5</td><td>92</td><td>108</td></tr> <tr><td>2.5</td><td>184</td><td>16</td><td>8.0</td><td>85</td><td>115</td></tr> <tr><td>3.0</td><td>176</td><td>24</td><td>8.5</td><td>78</td><td>122</td></tr> <tr><td>3.5</td><td>166</td><td>34</td><td>9.0</td><td>69</td><td>131</td></tr> <tr><td>4.0</td><td>155</td><td>45</td><td>9.5</td><td>60</td><td>140</td></tr> <tr><td>4.5</td><td>144</td><td>56</td><td>10.0</td><td>54</td><td>146</td></tr> <tr><td>5.0</td><td>134</td><td>66</td><td>10.5</td><td>49</td><td>151</td></tr> <tr><td>5.5</td><td>126</td><td>74</td><td>11.0</td><td>44</td><td>156</td></tr> <tr><td>6.0</td><td>118</td><td>82</td><td>11.5</td><td>33</td><td>167</td></tr> <tr><td>6.5</td><td>109</td><td>91</td><td>12.0</td><td>17</td><td>183</td></tr> <tr><td>7.0</td><td>99</td><td>101</td><td></td><td></td><td></td></tr> </tbody> </table> <p style="text-align: center;"><b>Table 1</b></p>	pH	A	B	pH	A	B	2.0	195	5	7.5	92	108	2.5	184	16	8.0	85	115	3.0	176	24	8.5	78	122	3.5	166	34	9.0	69	131	4.0	155	45	9.5	60	140	4.5	144	56	10.0	54	146	5.0	134	66	10.5	49	151	5.5	126	74	11.0	44	156	6.0	118	82	11.5	33	167	6.5	109	91	12.0	17	183	7.0	99	101				<p>Buffer solutions covering a wide pH range can be prepared by mixing solutions of boric acid, citric acid (<b>Irritant</b>) and sodium phosphate in different proportions.</p> <ul style="list-style-type: none"> <li>Solution <b>A</b> is a mixture containing <b>0.200 mol dm<sup>-3</sup> boric acid</b> and <b>0.0500 mol dm<sup>-3</sup> citric acid</b></li> <li>Solution <b>B</b> is <b>0.100 mol dm<sup>-3</sup> sodium phosphate (Na<sub>3</sub>PO<sub>4</sub>)</b></li> </ul> <p>Table 1 shows the volumes needed to make 200 cm<sup>3</sup> of a given buffer. These buffer solutions can be used to investigate the <b>effective ranges</b>, and <b>colour changes</b>, of acid–base indicators and to demonstrate the ‘buffering effect’. Table 2, which gives these data, should be used to check students’ results.</p> <p>It is unlikely that all of the indicators in Table 2 will be used, but the indicators chosen should cover as much of the pH range as possible. An individual student, or a small group could tackle the exercise but it would be just as effective, and less time-consuming, if it were undertaken as a class practical.</p> <p>A simple universal indicator (pH range of 1–13) may be prepared by dissolving thymol blue, methyl red, methyl orange, phenolphthalein and bromothymol blue in 95% ethanol (<b>Highly Flammable</b>). As the pH increases, the indicator changes colour from red to orange to yellow to green to blue and finally to purple.</p> <p>Students should prepare buffer solutions with pH values of 2, 3, 4 etc. and use them to investigate the colours of the individual indicators, and of the universal indicator.</p>	<p><b>Note:</b> This exercise provides students with experience in preparing and using buffer solutions and indicators – both traditionally difficult topics. The chemistry involved in this buffering system is complex but the working of the universal indicator, particularly if students are able to use each of the component indicators separately, will appeal to the artist among them!</p>
pH	A	B	pH	A	B																																																																						
2.0	195	5	7.5	92	108																																																																						
2.5	184	16	8.0	85	115																																																																						
3.0	176	24	8.5	78	122																																																																						
3.5	166	34	9.0	69	131																																																																						
4.0	155	45	9.5	60	140																																																																						
4.5	144	56	10.0	54	146																																																																						
5.0	134	66	10.5	49	151																																																																						
5.5	126	74	11.0	44	156																																																																						
6.0	118	82	11.5	33	167																																																																						
6.5	109	91	12.0	17	183																																																																						
7.0	99	101																																																																									



## Appendix 1

Syllabus section	Skills/Learning Outcomes	Notes	Sources																																										
	<table border="1"> <thead> <tr> <th><i>Indicator</i></th> <th><i>pH range</i></th> <th><i>Colour change</i></th> </tr> </thead> <tbody> <tr> <td>methyl violet</td> <td>0.0–1.6</td> <td>yellow to blue-violet</td> </tr> <tr> <td>thymol blue</td> <td>1.2–2.8</td> <td>red to yellow</td> </tr> <tr> <td>bromophenol blue</td> <td>3.0–4.6</td> <td>yellow to blue-violet</td> </tr> <tr> <td>methyl orange</td> <td>3.2–4.4</td> <td>red to yellow-orange</td> </tr> <tr> <td>methyl red</td> <td>4.4–6.2</td> <td>red to yellow</td> </tr> <tr> <td>litmus</td> <td>5–8</td> <td>pink to blue</td> </tr> <tr> <td>bromocresol purple</td> <td>5.2–6.8</td> <td>yellow to purple</td> </tr> <tr> <td>bromophenol red</td> <td>5.2–6.8</td> <td>yellow to red</td> </tr> <tr> <td>bromothymol blue</td> <td>6.2–7.6</td> <td>yellow to blue</td> </tr> <tr> <td>cresol red</td> <td>7.2–8.8</td> <td>yellow to red</td> </tr> <tr> <td>thymol blue</td> <td>8.0–9.6</td> <td>yellow to blue</td> </tr> <tr> <td>phenolphthalein</td> <td>8.0–10.0</td> <td>colourless to pink</td> </tr> <tr> <td>alizarin yellow</td> <td>10.0–12.0</td> <td>yellow to red-violet</td> </tr> </tbody> </table> <p style="text-align: center;"><b>Table 2</b></p>	<i>Indicator</i>	<i>pH range</i>	<i>Colour change</i>	methyl violet	0.0–1.6	yellow to blue-violet	thymol blue	1.2–2.8	red to yellow	bromophenol blue	3.0–4.6	yellow to blue-violet	methyl orange	3.2–4.4	red to yellow-orange	methyl red	4.4–6.2	red to yellow	litmus	5–8	pink to blue	bromocresol purple	5.2–6.8	yellow to purple	bromophenol red	5.2–6.8	yellow to red	bromothymol blue	6.2–7.6	yellow to blue	cresol red	7.2–8.8	yellow to red	thymol blue	8.0–9.6	yellow to blue	phenolphthalein	8.0–10.0	colourless to pink	alizarin yellow	10.0–12.0	yellow to red-violet	<p>They could then be asked to create a buffer solution having one of the intermediate pH values (3.5, 4.5, etc.); a different value for each student/group. The universal indicator could then be used to judge the accuracy of the buffers created. The buffering effect is demonstrated in point 7 below.</p> <p><b>Procedure</b></p> <ol style="list-style-type: none"> <li>Using the volumes of solutions <b>A</b> and <b>B</b> from Table 1, prepare buffer solutions for pH 2.0 to pH 12.0.</li> <li>Measure their pH using a pH meter (if available).</li> <li>Use these buffers to investigate the <b>effective range</b> and the <b>colour change</b> of the indicators provided.</li> <li>Prepare a 'Universal Indicator' by dissolving methyl red (0.04 g), methyl orange (0.02 g), phenolphthalein (0.02 g), thymol blue (0.10 g), and bromothymol blue (0.08 g) in 100 cm<sup>3</sup> of 95% ethanol.</li> <li>Use the buffers prepared in part 1 to investigate the colour of the UI solution across the pH range 2–12.</li> <li>Obtain a pH value from your teacher; deduce the volumes of <b>A</b> and <b>B</b> required and then prepare it. Use the universal indicator or a pH meter to find its pH.</li> <li>Add a few drops of 1.0 mol dm<sup>-3</sup> sodium hydroxide to a test tube containing 3 cm<sup>3</sup> of the pH 7 buffer, and also to a control tube containing 3 cm<sup>3</sup> of deionised water. Add a few drops of 1.0 mol dm<sup>-3</sup> hydrochloric acid (<b>Corrosive</b>) to a test tube containing 3 cm<sup>3</sup> of the pH 7 buffer, and also to a control tube containing 3 cm<sup>3</sup> of deionised water.</li> <li>To all four tubes, add a few drops of bromothymol blue indicator. Record and explain your results.</li> </ol> <p><b>Timing:</b> 1–1.5 hours</p>	
<i>Indicator</i>	<i>pH range</i>	<i>Colour change</i>																																											
methyl violet	0.0–1.6	yellow to blue-violet																																											
thymol blue	1.2–2.8	red to yellow																																											
bromophenol blue	3.0–4.6	yellow to blue-violet																																											
methyl orange	3.2–4.4	red to yellow-orange																																											
methyl red	4.4–6.2	red to yellow																																											
litmus	5–8	pink to blue																																											
bromocresol purple	5.2–6.8	yellow to purple																																											
bromophenol red	5.2–6.8	yellow to red																																											
bromothymol blue	6.2–7.6	yellow to blue																																											
cresol red	7.2–8.8	yellow to red																																											
thymol blue	8.0–9.6	yellow to blue																																											
phenolphthalein	8.0–10.0	colourless to pink																																											
alizarin yellow	10.0–12.0	yellow to red-violet																																											

## Appendix 1

Syllabus section	Skills/Learning Outcomes	Notes	Sources
8e, 8k, 9.5g, 9.5n	<p><b>11. Catalysis – use of Fe<sup>3+</sup> in I<sup>-</sup>/S<sub>2</sub>O<sub>8</sub><sup>2-</sup> reaction</b></p> <ul style="list-style-type: none"> <li>Perform a 'rates' experiment with accuracy and precision</li> <li>Understand the use of transition metal ions as homogeneous catalysts in terms of the variability of their oxidation states</li> </ul>	<p>The oxidation of iodide ions by peroxodisulphate ions, S<sub>2</sub>O<sub>8</sub><sup>2-</sup>, may be represented by the equation below.</p> $2\text{I}^{-}(\text{aq}) + \text{S}_2\text{O}_8^{2-}(\text{aq}) \rightleftharpoons 2\text{SO}_4^{2-}(\text{aq}) + \text{I}_2(\text{aq})$ <p>As the reaction is between two negatively charged ions, repulsion between these ions causes it to have a high activation energy and so it is relatively slow at room temperature. Transition metals ions can act as <b>homogeneous</b> catalysts in this reaction; being positive, they are attracted to the appropriate negative ion. When Fe<sup>3+</sup>(aq) ions are present, iodide ions reduce them to Fe<sup>2+</sup>(aq) ions which are then oxidised back to Fe<sup>3+</sup>(aq) ions by S<sub>2</sub>O<sub>8</sub><sup>2-</sup>(aq) ions.</p> <p>This exercise is essentially an 'iodine clock' reaction. A convenient way to measure the rate of this reaction is to add a fixed volume of aqueous sodium thiosulphate to the reaction mixture. This reacts with the free iodine formed in the reaction. When the sodium thiosulphate has been used up, free iodine is produced. As starch solution has also been added, a deep blue colour will be produced.</p> <p><b>Procedure</b></p> <ol style="list-style-type: none"> <li>Mix, in a conical flask, 10 cm<sup>3</sup> of 0.1 mol dm<sup>-3</sup> aqueous sodium thiosulphate, 10 cm<sup>3</sup> of 0.2 mol dm<sup>-3</sup> aqueous potassium iodide and 5 cm<sup>3</sup> of starch solution.</li> <li>Add 20 cm<sup>-3</sup> of saturated aqueous potassium peroxodisulphate (<b>Oxidising, Harmful</b>) (about 75 g dm<sup>-3</sup>). Start the stop clock and swirl the flask.</li> <li>Note and record the time when the solution turns blue.</li> <li>Repeat steps 1 to 3 but, in step 1, add 0.5 cm<sup>3</sup> of aqueous iron(III) chloride (about 0.1 mol dm<sup>-3</sup>).</li> <li>Repeat steps 1 to 3 several times, adding gradually increasing volumes of aqueous iron(III) chloride.</li> </ol>	<p>This exercise is an extension of the 'rates' exercises described in <i>Teaching AS Chemistry Practical Skills</i>, Appendix 1.</p>

## Appendix 1

Syllabus section	Skills/Learning Outcomes	Notes	Sources
		<p>If time allows, repeat the experiment but use solutions containing <math>\text{Cr}^{3+}(\text{aq})</math>, <math>\text{Cu}^{2+}(\text{aq})</math> or <math>\text{Co}^{2+}(\text{aq})</math> ions in place of the aqueous iron(III) chloride.</p> <p><b>Timing:</b> at least 1 hour</p> <p><b>Note:</b> This exercise could be used as a test of planning skills. Students would be given the equation for the reaction and the concentration of each solution. They would then be required to write a detailed plan, including quantities and full practical details. <b>Timing:</b> up to 1 hour</p>	

## Appendix 1

Syllabus section	Skills/Learning Outcomes	Notes	Sources
8e, 8k, 9.5g	<p><b>12. Titration of <math>\text{MnO}_4^-/\text{H}^+</math> against <math>\text{C}_2\text{O}_4^{2-}</math> to show autocatalysis</b></p> <ul style="list-style-type: none"> <li>Perform a 'rates' experiment with accuracy and precision</li> <li>Calculate concentrations from titration data</li> <li>Analyse data graphically</li> <li>Understand autocatalysis and 'quenching'/'stopping' a reaction</li> </ul>	<p>Potassium manganate(VII) (<b>Oxidising, Harmful, Dangerous to the environment</b>) can oxidise ethanedioic acid (<b>Harmful</b>) as shown in the equation below.</p> $2\text{MnO}_4^-(\text{aq}) + 6\text{H}^+(\text{aq}) + 5\text{C}_2\text{O}_4^{2-}(\text{aq}) \rightarrow 2\text{Mn}^{2+}(\text{aq}) + 8\text{H}_2\text{O}(\text{l}) + 10\text{CO}_2(\text{g})$ <p>The reaction is performed without the use of a catalyst in Experiment 1 but a catalyst is added to Experiment 2. The graph for Experiment 1 will show the reaction rate increasing with time before the graph eventually moves towards a more 'normal' shape. If time permits, it might be useful for students to take gradients from this graph and to plot the rates obtained from this against time. Comparison of the graphs for the two experiments will allow the term <i>autocatalysis</i> to be introduced and explained.</p> <p>Students can investigate the catalytic action of <math>\text{Mn}^{2+}(\text{aq})</math> ions in this reaction by repeating Experiment 1 but adding 1, 2, 4 or 6 drops of the manganese(II) sulphate solution. They will find that the addition of <math>\text{Mn}^{2+}(\text{aq})</math> ions moves the <math>[\text{MnO}_4^-]</math> vs. time graph to the left and also that, if sufficient <math>\text{Mn}^{2+}(\text{aq})</math> ions are added, the increase in rate will not occur at all.</p> <p><b>Procedure</b> Prepare the reaction mixtures given below using measuring cylinders. Some members of the class should do Experiment 1 and some Experiment 2 (8 steps each). The results should then be shared.</p> <p><b>Experiment 1</b></p> <ol style="list-style-type: none"> <li>Mix <math>100 \text{ cm}^3</math> of <math>0.200 \text{ mol dm}^{-3}</math> aqueous ethanedioic acid, <math>5 \text{ cm}^3</math> of <math>2 \text{ mol dm}^{-3}</math> sulphuric acid (<b>Corrosive</b>) and <math>95 \text{ cm}^3</math> of water in a <math>500 \text{ cm}^3</math> flask.</li> </ol>	<p>Details of similar experiments can be found in many A level practical books.</p>

## Appendix 1

Syllabus section	Skills/Learning Outcomes	Notes	Sources
		<p><b>Experiment 2</b></p> <ol style="list-style-type: none"> <li>Mix 100 cm<sup>3</sup> of 0.200 mol dm<sup>-3</sup> aqueous ethanedioic acid, 15 cm<sup>3</sup> of 0.200 mol dm<sup>-3</sup> aqueous manganese(II) sulphate, 5 cm<sup>3</sup> of 2 mol dm<sup>-3</sup> sulphuric acid and 95 cm<sup>3</sup> of water in a 500 cm<sup>3</sup> flask.</li> <li>Add 50 cm<sup>3</sup> of 0.020 mol dm<sup>-3</sup> aqueous potassium manganate(VII) and start timing. Shake the mixture for about half a minute to mix it well.</li> <li>After about a minute use a pipette and safety pipette filler to withdraw a 10 cm<sup>3</sup> portion of the reaction mixture and run it into a conical flask.</li> <li>Note the time and add about 10 cm<sup>3</sup> of 0.1 mol dm<sup>-3</sup> aqueous potassium iodide. This stops the reaction and releases iodine equivalent to the residual manganate(VII) ions.</li> <li>Titrate the liberated iodine with 0.010 mol dm<sup>-3</sup> sodium thiosulphate, adding a little starch solution near the end point. Record the titre of sodium thiosulphate.</li> <li>Remove further portions at least every 3 or 4 minutes. Treat each portion as described in steps 4 and 5. Continue until the titre is less than 3 cm<sup>3</sup>.</li> <li>Deduce, from the titre values, the concentration of MnO<sub>4</sub><sup>-</sup> (aq) ions present in each portion.</li> <li>Plot a graph of [MnO<sub>4</sub><sup>-</sup>] vs. time for each experiment.</li> </ol> <p>Compare the shapes of the two graphs. Explain any differences you see.</p> <p><b>Timing:</b> 1 hour</p> <p><b>Note:</b> Alternatively, the change in concentration of MnO<sub>4</sub><sup>-</sup>(aq) ions could be followed using a colorimeter. Coupling this to a computer or 'data-logger' would allow the concentration vs. time graph to be generated automatically.</p>	

## Appendix 1

Syllabus section	Skills/Learning Outcomes	Notes	Sources
8f, 11.1	<b>13. Experiments with enzymes – the effect of enzyme concentration on rate</b>		
	<ul style="list-style-type: none"> <li>Handle small volumes of liquid</li> <li>Deduce organic structures</li> <li>Practice mole calculations</li> <li>Analyse and evaluate results</li> </ul>	<p>This experiment requires students to investigate the effect of lipase concentration on the rate of hydrolysis of a lipid. This exercise could be used to provide practical experience prior to the students tackling the planning exercise in Experiment 14.</p> <p><b>Timing:</b> 1–1.5 hours</p>	<p><b>Appendix 4</b> This experiment is based on material from the syllabus support booklet <i>Applications of Chemistry</i>.</p>
8f, 11.1	<b>14. Experiments with enzymes – planning an enzyme concentration vs. rate experiment</b>		
	<ul style="list-style-type: none"> <li>Produce a detailed plan of how the experiments will be performed</li> <li>Deduce the quantities of solutions to be used</li> <li>Identify the apparatus needed</li> <li>Decide on how the results will be analysed and evaluated</li> <li>Assess the risks involved and suggest appropriate safety precautions</li> </ul>	<p>The first part of this exercise requires students to <b>plan</b> an experiment to investigate the effect of an enzyme (urease) concentration on the rate of hydrolysis of urea. A fully written-up plan is provided to allow students to perform the experiment (if their own plan proves to be not feasible).</p> <p><b>Timing:</b> planning – about 1 hour, experiment – about 1 hour</p>	<p><b>Appendix 4</b> This experiment is based on material from the syllabus support booklet <i>Applications of Chemistry</i>.</p>

## Appendix 1

Syllabus section	Skills/Learning Outcomes	Notes	Sources
8g, 8h, 8j	<p><b>15. Rate order for hydrogen peroxide/potassium iodide reaction (includes some planning)</b></p> <ul style="list-style-type: none"> <li>• Measure liquid volumes using a burette</li> <li>• Use a stopclock</li> <li>• Adapt an experiment to measure the effect of a different variable</li> <li>• Analyse data graphically</li> <li>• Deduce rate orders, write a rate equation and calculate a value for the rate constant</li> </ul>	<p>In this exercise, the effects on the initial rate of reaction of changing the concentrations of hydrogen peroxide (<b>Corrosive</b>), potassium iodide and acid are investigated. The data obtained are graphically analysed and the rate order with respect to each component is deduced. Full details are provided for the rate order with respect to the concentration of potassium iodide; the remaining two experiments involve some planning. Finally, students are required to evaluate their experiments and to suggest possible improvements.</p> <p>As an extension, students can be set a challenge which will develop their planning skills.</p> <p><b>Timing:</b> about 1 hour per experiment. It may be better to work in groups of 3 students, with each student performing one experiment.</p>	<p><b>Appendix 2</b></p>

## Appendix 1

Syllabus section	Skills/Learning Outcomes	Notes	Sources																																																
8g	<p><b>16. Rate orders for the propanone / iodine reaction</b></p> <ul style="list-style-type: none"> <li>Perform a 'rates' experiment with accuracy and precision</li> <li>Learn about 'quenching' a reaction</li> <li>Calculate concentrations from titration data</li> <li>Analyse data graphically</li> <li>Deduce rate orders</li> <li>Write a rate equation based on the deduced rate orders</li> <li>Calculate the rate constant</li> </ul> <table border="1"> <thead> <tr> <th>Mixture</th> <th colspan="5">Volume / cm<sup>3</sup></th> </tr> <tr> <th></th> <th>1</th> <th></th> <th></th> <th></th> <th></th> </tr> </thead> <tbody> <tr> <td>I<sub>2</sub> solution</td> <td>30.0</td> <td>30.0</td> <td>30.0</td> <td>60.0</td> <td>30.0</td> </tr> <tr> <td>CH<sub>3</sub>COCH<sub>3</sub> solution</td> <td>30.0</td> <td>60.0</td> <td>30.0</td> <td>30.0</td> <td>30.0</td> </tr> <tr> <td>HCl dilute</td> <td>30.0</td> <td>30.0</td> <td>90.0</td> <td>30.0</td> <td>60.0</td> </tr> <tr> <td>H<sub>2</sub>O</td> <td>60.0</td> <td>30.0</td> <td>0.0</td> <td>30.0</td> <td>30.0</td> </tr> <tr> <td>Total</td> <td>150</td> <td>150</td> <td>150</td> <td>150</td> <td>150</td> </tr> <tr> <td>Initial rate / mol dm<sup>-3</sup>s<sup>-1</sup></td> <td></td> <td></td> <td></td> <td></td> <td></td> </tr> </tbody> </table>	Mixture	Volume / cm <sup>3</sup>						1					I <sub>2</sub> solution	30.0	30.0	30.0	60.0	30.0	CH <sub>3</sub> COCH <sub>3</sub> solution	30.0	60.0	30.0	30.0	30.0	HCl dilute	30.0	30.0	90.0	30.0	60.0	H <sub>2</sub> O	60.0	30.0	0.0	30.0	30.0	Total	150	150	150	150	150	Initial rate / mol dm <sup>-3</sup> s <sup>-1</sup>						<p>In this exercise, students determine the rate equation for:  <math>I_2(aq) + CH_3COCH_3(aq) \rightarrow CH_2ICOCH_3(aq) + HI(aq)</math></p> <p><b>Note:</b> The reaction is catalysed by H<sup>+</sup> ions from HCl(aq), therefore, [HCl] appears in the rate equation.  The rate equation for this reaction may be written as:  <math>R = k[CH_3COCH_3]^a[I_2]^b[HCl]^c</math></p> <p><b>Materials:</b></p> <ul style="list-style-type: none"> <li>0.0100 mol dm<sup>-3</sup> I<sub>2</sub>(aq) (2.54 g of I<sub>2</sub> + 8.0 g of KI in 1.0 dm<sup>3</sup> of solution)</li> <li>1.0 mol dm<sup>-3</sup> CH<sub>3</sub>COCH<sub>3</sub>(aq) (71.0 cm<sup>3</sup> CH<sub>3</sub>COCH<sub>3</sub> in 1.0 dm<sup>3</sup> of solution)</li> <li>2.0 mol dm<sup>-3</sup> HCl(aq)</li> <li><b>saturated</b> NaHCO<sub>3</sub>(aq)</li> <li>1% starch solution</li> <li>distilled/deionised water</li> </ul> <p>Assign one of the mixtures, 1–5 in the table, to each of five groups. Each group will need five 250 cm<sup>3</sup> conical flasks, labelled <b>A</b> to <b>E</b>. In each flask, they put about 60 cm<sup>3</sup> of <b>saturated</b> NaHCO<sub>3</sub>(aq) (to quench the reaction). In a separate 250 cm<sup>3</sup> conical flask, the assigned mixture, without the propanone (<b>Highly Flammable</b>), is prepared. The propanone is then added, with swirling and the clock is started. Immediately, a 25.0 cm<sup>3</sup> portion is removed using a pipette (+ filler), and added to flask <b>A</b>. the time is noted when the pipette is <b>half empty</b> (but the clock is <b>NOT</b> stopped).</p>	<p>Details of similar experiments can be found in many A level practical books.</p>
Mixture	Volume / cm <sup>3</sup>																																																		
	1																																																		
I <sub>2</sub> solution	30.0	30.0	30.0	60.0	30.0																																														
CH <sub>3</sub> COCH <sub>3</sub> solution	30.0	60.0	30.0	30.0	30.0																																														
HCl dilute	30.0	30.0	90.0	30.0	60.0																																														
H <sub>2</sub> O	60.0	30.0	0.0	30.0	30.0																																														
Total	150	150	150	150	150																																														
Initial rate / mol dm <sup>-3</sup> s <sup>-1</sup>																																																			



## Appendix 1

Syllabus section	Skills/Learning Outcomes	Notes	Sources
		<p>Swirl flask <b>A</b>. This sample is now quenched and the reaction has stopped. Immediately, repeat this process by taking a second 25.0 cm<sup>3</sup> sample of the reaction mixture, and adding it to flask <b>B</b>, again noting the time when the pipette is half empty. Repeat the process three more times, at about 1 minute intervals, adding the reaction solutions to flasks <b>C</b>, <b>D</b> and <b>E</b>, each time noting the time when the pipette is half empty. The mixtures in the flasks <b>A</b> to <b>E</b> are each titrated with 0.010 mol dm<sup>-3</sup> Na<sub>2</sub>S<sub>2</sub>O<sub>3</sub>(aq). From these titres the [I<sub>2</sub>(aq)] value in each flask is calculated. A graph of time (in seconds) vs. [I<sub>2</sub>(aq)] is drawn for each mixture. The gradient of the tangent at t = 0, is the initial rate for the reaction. The initial rates for each mixture are entered into the table. Students use this data to deduce values for the three rate orders; for example, the relationship between the initial rates in mixtures 1 and 2, gives rate order 'a'.</p> <p><b>Timing:</b> 1 hour</p> <p><b>Note:</b> Alternatively, the change in iodine concentration could be followed using a colorimeter. Coupling this to a computer or 'data-logger' would allow the concentration vs. time graph to be generated automatically.</p>	

## Appendix 1

Syllabus section	Skills/Learning Outcomes	Notes	Sources																														
9.5i, 9.5j, 9.5m, 9.5n	<p><b>17. Determination of the formula of complex ions</b></p> <ul style="list-style-type: none"> <li>Work with care and precision</li> <li>Make clear and careful observations</li> <li>Record observations appropriately</li> <li>Plan a volumetric analysis exercise</li> <li>Deduce the formula of the complex ions formed</li> </ul> <table border="1"> <thead> <tr> <th>tube</th> <th>vol. of 0.050 mol dm<sup>-3</sup> CuSO<sub>4</sub> / cm</th> <th>vol. of 0.050 mol dm<sup>-3</sup> 1,2-diaminoethane / cm</th> </tr> </thead> <tbody> <tr><td>1</td><td>0.0</td><td>12.0</td></tr> <tr><td>2</td><td>2.0</td><td>10.0</td></tr> <tr><td>3</td><td>3.0</td><td>9.0</td></tr> <tr><td>4</td><td>4.0</td><td>8.0</td></tr> <tr><td>5</td><td>6.0</td><td>6.0</td></tr> <tr><td>6</td><td>8.0</td><td>4.0</td></tr> <tr><td>7</td><td>9.0</td><td>3.0</td></tr> <tr><td>8</td><td>10.0</td><td>2.0</td></tr> <tr><td>9</td><td>12.0</td><td>0.0</td></tr> </tbody> </table>	tube	vol. of 0.050 mol dm <sup>-3</sup> CuSO <sub>4</sub> / cm	vol. of 0.050 mol dm <sup>-3</sup> 1,2-diaminoethane / cm	1	0.0	12.0	2	2.0	10.0	3	3.0	9.0	4	4.0	8.0	5	6.0	6.0	6	8.0	4.0	7	9.0	3.0	8	10.0	2.0	9	12.0	0.0	<p>The source describes two experiments by which the formulae of complex ions may be deduced.</p> <p>Experiment 1 works best if the intensity of colour of the complex ion is measured using a colorimeter but it could be followed using the naked eye.</p> <p>Experiment 2 involves the displacement of one ligand (murexide) by a stronger ligand (EDTA<sup>2-</sup>) in an aqueous Ni<sup>2+</sup> complex. The colour of the Ni<sup>2+</sup>/murexide complex is predominant and so the colour of the Ni<sup>2+</sup>/EDTA complex is only seen when all the murexide has been displaced. Murexide can therefore act as an indicator in Ni<sup>2+</sup>/EDTA<sup>2-</sup> titrations.</p> <p><b>Experiment 1</b></p> <p>Copper(II) ions complex with 1,2-diaminoethane as shown in the equation below.</p> $\text{Cu}^{2+}(\text{aq}) + x\text{H}_2\text{NCH}_2\text{CH}_2\text{NH}_2 \rightarrow [\text{Cu}(\text{H}_2\text{NCH}_2\text{CH}_2\text{NH}_2)_x]^{2+}$ <p><b>Procedure</b></p> <ol style="list-style-type: none"> <li>Prepare the nine mixtures given in the table provided.</li> <li>Measure the absorption of each mixture using a colorimeter.</li> <li>Plot a graph of absorption against the volume of CuSO<sub>4</sub>(aq) added.</li> <li>Identify the mixture which gives the maximum colour intensity.</li> </ol> <p>Determine the molar proportions of Cu<sup>2+</sup> and H<sub>2</sub>NCH<sub>2</sub>CH<sub>2</sub>NH<sub>2</sub> present in this mixture and hence deduce the value of 'x' in the formula of the complex.</p>	See <i>Chemistry in Context</i> – third edition; Hill & Holman Practical 13 for full details of these experiments
tube	vol. of 0.050 mol dm <sup>-3</sup> CuSO <sub>4</sub> / cm	vol. of 0.050 mol dm <sup>-3</sup> 1,2-diaminoethane / cm																															
1	0.0	12.0																															
2	2.0	10.0																															
3	3.0	9.0																															
4	4.0	8.0																															
5	6.0	6.0																															
6	8.0	4.0																															
7	9.0	3.0																															
8	10.0	2.0																															
9	12.0	0.0																															

## Appendix 1

Syllabus section	Skills/Learning Outcomes	Notes	Sources
		<p><b>Experiment 2</b></p> <p><b>Procedure</b></p> <ol style="list-style-type: none"> <li>1. Add 5 drops of aqueous murexide (0.5 g in 100 cm<sup>3</sup> of water) to 5.0 cm<sup>3</sup> of 0.1 mol dm<sup>-3</sup> aqueous nickel(II) sulphate. (<b>Harmful, Harmful to environment</b>)</li> <li>2. Using a teat pipette, add 0.1 mol dm<sup>-3</sup> aqueous EDTA (disodium salt) slowly until no further changes occur.</li> <li>3. Write a plan for a titration to determine the volume of aqueous EDTA with a known volume of the nickel(II) sulphate solution.</li> <li>4. Discuss your plan with your teacher and then perform the titration.</li> <li>5. Deduce the molar proportions of Ni<sup>2+</sup> and EDTA<sup>2-</sup> present at the end-point of your titration and hence deduce the formula of the Ni<sup>2+</sup>/EDTA<sup>2-</sup> complex.</li> </ol> <p><b>Timing:</b> 1 hour per experiment</p>	

## Appendix 1

Syllabus section	Skills/Learning Outcomes	Notes	Sources
9.5j	<p><b>18. Ligand Exchange (Cu<sup>2+</sup> complexes)</b></p> <ul style="list-style-type: none"> <li>• Work with care and precision</li> <li>• Make clear and careful observations</li> <li>• Record observations appropriately</li> <li>• Deduce the identity and structures of the complex ions formed</li> <li>• Write equations for any reactions occurring</li> </ul>	<p>In this exercise, students investigate the changes which occur when water is replaced as the ligand in the [Cu(H<sub>2</sub>O)<sub>6</sub>]<sup>2+</sup> complex ion. Deprotonation is demonstrated by the use of hydroxide ions, and ligand replacement by the use of ammonia and chloride ions. The reversible nature of many ligand exchange processes is shown by the hydrochloric acid reaction.</p> <p>Use a stock solution of copper(II) sulphate (<b>Harmful, Harmful to environment</b>) (about 0.25 mol dm<sup>-3</sup>).</p> <ol style="list-style-type: none"> <li>To separate samples of CuSO<sub>4</sub>(aq):             <ol style="list-style-type: none"> <li>add dilute NaOH(aq) <b>drop by drop</b>, with shaking until no further changes occur</li> <li>add dilute NH<sub>3</sub>(aq) drop by drop, with shaking until no further changes occur</li> <li>add concentrated hydrochloric acid (<b>Corrosive</b>) drop by drop, with shaking until no further changes occur. Then add water gradually, again until no further change is observed</li> </ol> </li> <li>Describe your observations and write equations for any reactions occurring.</li> <li>Draw the structures, and give the name, of each complex ion present in your equations.</li> </ol> <p><b>Note:</b> The [Cu(NH<sub>3</sub>)<sub>4</sub>(H<sub>2</sub>O)<sub>2</sub>]<sup>2+</sup> ion is octahedral in shape but the H<sub>2</sub>O ligands are further away than the NH<sub>3</sub> ligands from the central copper ion and they are on opposite sides of the complex.</p> <p><b>Timing:</b> 30 minutes</p>	<p><i>Chemistry in Context</i> – third edition, Hill &amp; Holman Practical 23</p> <p>This covers a wide range of copper chemistry, of which this exercise is but a small part</p>

## Appendix 1

Syllabus section	Skills/Learning Outcomes	Notes	Sources
10.2j, 10.2k, 10.4d, 10.7(a)	<p><b>19. The preparation and purification of methyl 3-nitrobenzoate (plus possible reduction to the aryl amine)</b></p> <ul style="list-style-type: none"> <li>• Determine the weight of a material using the <b>weighing by difference</b> method</li> <li>• Handle hazardous materials safely</li> <li>• Purify by recrystallisation</li> <li>• Determine the yield and melting point of a reaction product</li> <li>• Estimate the purity of a reaction product</li> <li>• Write a mechanism for the electrophilic substitution reaction involved in nitration</li> </ul>	<p>This experiment is a fairly straightforward organic synthesis; however, the reagents used must be handled with care. The nitrated product is purified by recrystallisation and its purity is estimated by measuring its melting point. Overall, the exercise requires students to practice a wide range of organic preparative skills.</p> <p><b>Timing:</b> 1.5–2 hours over two sessions</p> <p><b>Note:</b> The extension of the exercise to reduce the nitro product to an aryl amine requires considerable practical experience but does offer a natural conclusion to the synthesis.</p>	<p><b>Appendix 2</b></p> <p>For details of the reduction to the aryl amine see <i>Advanced Practical Chemistry</i>, J S Clarke &amp; S Clynes (4.53) (English University Press)</p>

## Appendix 1

Syllabus section	Skills/Learning Outcomes	Notes	Sources
10.4c, 10.5e	<p><b>20. Triiodomethane (iodoform) test for <math>\beta</math>-hydroxy and <math>\beta</math>-keto groups</b></p> <ul style="list-style-type: none"> <li>Use the 'iodoform' test to detect the presence of <math>\beta</math>-hydroxy and <math>\beta</math>-keto groups</li> <li>Isolate, purify and determine melting point</li> <li>Plan the preparation and the estimation of purity of a sample of triiodomethane</li> </ul>	<p>This test could form a useful addition to the AS exercises on alcohols and carbonyl compounds, although it would only be assessed at A2 level. The test detects the presence of the <math>\beta</math>-keto group, <math>\text{CH}_3\text{CO}-</math>, in a compound. This group may be present either in the original compound, or because it is formed in the reaction mixture from a <math>\beta</math>-hydroxy, <math>\text{CH}_3\text{CH}(\text{OH})-</math> group in the original compound.</p> <p>Isolating the product, recrystallising it and determining its melting point could extend the exercise. This sequence could be used as the basis of an assessment of planning skills.</p> <p><b>Test 1</b></p> <ol style="list-style-type: none"> <li>To <math>0.2 \text{ cm}^3</math> of the test sample add <math>2 \text{ cm}^3</math> of <math>0.5 \text{ mol dm}^{-3}</math> aqueous potassium iodide and <math>4 \text{ cm}^3</math> of <math>1.0 \text{ mol dm}^{-3}</math> aqueous sodium chlorate(I) (<b>Oxidising, Harmful</b>).</li> <li>Warm the mixture to <b>50 °C</b> (323 K), using a water bath, for two minutes.</li> <li>Cool the mixture; fine yellow crystals separate out.</li> </ol> <p><b>Note:</b></p> <p>Instead of using the above reagents, you may use a <math>4 \text{ cm}^3</math> portion of <math>0.2 \text{ mol dm}^{-3}</math> aqueous iodine, to which has been added <b>just sufficient</b> aqueous sodium hydroxide (<b>Corrosive</b>) to decolourise the solution.</p> <p><b>Timing:</b> 30 minutes to 1 hour</p>	<p>Details of this test can be found in many A level practical books.</p> <p>It could be combined with AS exercises 28 and 29 in Appendix 1</p>

## Appendix 1

Syllabus section	Skills/Learning Outcomes	Notes	Sources
10.5c, 10.5d, 10.5e, 11.2d, 11.2h	<p><b>21. Planning an experiment to identify a carbonyl compound</b></p> <ul style="list-style-type: none"> <li>Identify the relevant structural features of carbonyl compounds</li> <li>Select suitable tests to use to identify an unknown carbonyl compound</li> <li>Give outline details of each test, including possible observations</li> <li>Outline the preparation and purification of a solid derivative</li> <li>Discuss the use of spectroscopic data in confirming identity</li> <li>Assess the risks involved and suggest appropriate safety precautions</li> </ul>	<p>In this exercise, students will be assessed on their ability to plan experiments to identify a carbonyl compound. They are presented with a group of five aldehydes and ketones and they will have to use their knowledge of the chemistry of carbonyl compounds to plan the experiments. They will also be required to explain how they would use spectroscopic data to confirm their identification.</p> <p>Guidance is given regarding the approach to be adopted, and a possible mark scheme is outlined.</p> <p><b>Timing:</b> up to 1 hour</p> <p><b>Note:</b> This planning exercise is based on AS carbonyl chemistry, the A2 triiodomethane/iodoform test and spectroscopic analysis.</p>	<p><b>Appendix 2</b></p>

## Appendix 1

Syllabus section	Skills/Learning Outcomes	Notes	Sources
10.6e, 10.6d, 10.7k, 10.8c, 11.3c	<p><b>22. Nylon rope trick</b></p> <ul style="list-style-type: none"> <li>Recall that polyamides are prepared by reaction between a diamine and a diacid or diol (diacid) dichloride</li> <li>Understand that varying the reactants alters the characteristics of a polymer</li> <li>Understand the relative reactivity of acid chlorides and carboxylic acids</li> <li>Handle hazardous materials safely</li> </ul>	<p>The polymerisation method is termed <b>interfacial polycondensation</b>. This exercise produces nylon 6,10; to prepare nylon 6,6 use adipoyl chloride in place of sebacoyl chloride.</p> <p>A film of nylon forms at the interface between two immiscible liquids. When the film is lifted, it is continuously replaced, resulting in the formation of a hollow thread of nylon. This thread or 'rope' can be steadily wound onto a stirring rod, wooden spill or roller until one of the reactants is exhausted. Preparing the solutions (wear gloves and safety goggles).</p> <p><b>Solution A</b> Mix 6.0 g of 1,6-diaminohexane (<b>Corrosive, Harmful by inhalation, ingestion and skin absorption</b>), 2.0 g of sodium hydroxide (<b>Corrosive</b>) and 100 cm<sup>3</sup> of deionised water in a bottle; cork and shake to dissolve.</p> <p><b>Solution B</b> Add 2.0 g (1.6 cm<sup>3</sup>) of sebacoyl chloride (<b>Corrosive, Lachrymatory, Irritant</b>) to 100 cm<sup>3</sup> of hexane in a bottle; cork and shake to mix.</p> <p><b>Procedure</b></p> <ol style="list-style-type: none"> <li>Transfer solution <b>A</b> to a 250 cm<sup>3</sup> beaker and <b>carefully</b> pour solution <b>B</b>, down a glass rod, into the same beaker.</li> <li><b>Gently</b>, using tweezers/forceps, lift the polymer film that forms at the interface and wind it onto a stirring rod/wooden spill.</li> <li>Wind up the nylon strand at a steady pace.</li> </ol>	<p>A number of Internet websites show details of this reaction; some have video clips of the process.</p> <p>Also see <i>Classic Chemistry Demonstrations</i>, The Royal Society of Chemistry – Experiment 64</p>



## Appendix 1

Syllabus section	Skills/Learning Outcomes	Notes	Sources
		<p>4. Wash the polymer <b>very thoroughly</b> with water, ethanol or ethanol/propanone (1:1) before handling, as traces of the reactant solutions will be trapped in the polymer tube as it is lifted up.</p> <p><b>Timing:</b> as a demonstration, about 10 minutes</p>	

## Appendix 1

Syllabus section	Skills/Learning Outcomes	Notes	Sources
10.6d, 10.6e, 10.7f	<p><b>23. Preparation of benzamide by the reaction of benzoyl chloride with ammonia</b></p> <ul style="list-style-type: none"> <li>Isolate, purify and determine melting point</li> <li>Handle hazardous materials safely</li> </ul>	<p>This preparation is relatively straightforward and does demonstrate just how reactive acid chlorides are. It produces a benzamide, which is a solid that is easily purified by recrystallisation. However, the reactants are <b>very harmful</b> and must be handled with great care. The reaction produced <math>\text{HCl}</math> fumes, which create pressure in the flask and so must be periodically released. Also, any benzoyl chloride spillage must be washed <b>immediately</b> with water. The fumes from both reactants cause severe breathing difficulties. This experiment – up to the point of recrystallisation – <b>must be performed in a fume cupboard</b>.</p> <p><b>Procedure (Use a fume cupboard)</b></p> <ol style="list-style-type: none"> <li><b>Wear gloves.</b> Using a measuring cylinder, transfer <math>25 \text{ cm}^3</math> of '<b>0.880</b>' ammonia (<b>Corrosive, Harmful to environment</b>) and <b><math>25 \text{ cm}^3</math> of water</b> to a <math>250 \text{ cm}^3</math> conical flask.</li> <li>Gradually add <b><math>10 \text{ cm}^3</math> of benzoyl chloride (Corrosive)</b> stopper the flask and shake well for 15 minutes (hold on to the stopper). The mixture will become warm; occasionally remove the stopper to relieve the pressure. <b>Do not spill</b> any of the contents.</li> <li>Filter off the white flakes of benzamide, wash with <b>cold</b> water (about <b><math>10 \text{ cm}^3</math></b>), and recrystallise from the minimum volume of hot water. Dry the crystals.</li> <li>Record your yield; determine the percentage yield, and the m.p. of the dry sample.</li> <li>Write a balanced equation for the reaction.</li> </ol> <p><b>Timing:</b> 1 hour (perhaps over two sessions)</p>	<p>Details of this preparation can be found in many A level practical books.</p>

## Appendix 1

Syllabus section	Skills/Learning Outcomes	Notes	Sources
10.7d, 10.7e	<p><b>24. Making an azo dye</b></p> <ul style="list-style-type: none"> <li>Perform a reaction under low temperature conditions</li> <li>Appreciate the need to work with care and precision</li> <li>Recall the chemistry of diazotisation and coupling</li> </ul>	<p>In the exercise, an azo dye is made using simple techniques. However, great care is required in ensuring temperature control and the safe handling of materials.</p> <p>This exercise provides an attractive practical experience and coverage of the chemistry of diazotisation/coupling. It could be extended to cover: the electrophilic substitution mechanism involved, the origin of colour in extended delocalised systems, the position of substitution in a substituted arene and making other azo dyestuffs.</p> <p><b>Timing:</b> 30 minutes to 1 hour</p>	<p><b>Appendix 4</b> See also <i>Chemistry in Context</i> – third edition, Hill &amp; Holman Practical 34 and <i>Advanced Physical Chemistry</i> – J S Clarke &amp; S Clynes (4.58)</p>

## Appendix 1

Syllabus section	Skills/Learning Outcomes	Notes	Sources
10.7f	<b>25. Planning the preparation and purification of <i>N</i>-phenylethanamide</b>		<b>Appendix 2</b>
	<p><b>Planning</b></p> <ul style="list-style-type: none"> <li>Produce a detailed plan whereby a specified quantity of purified product may be prepared</li> <li>Decide how the yield of product will be calculated</li> <li>Decide how the purity of the product will be assessed</li> <li>Assess the risks involved and suggest appropriate safety precautions</li> </ul>	<p>This exercise is primarily intended to give students practice in planning an organic preparation. Their plans should cover method, apparatus, and purification of the product. The quantities proposed must take account of the percentage yield of the reaction. The plan should also include details of how the purity of the product will be estimated.</p> <p><b>Timing:</b> up to 1 hour</p> <p><b>Note:</b> The syllabus requires students to show an understanding of the chemistry of acyl chlorides. Given the hazards associated with this class of compound, the use of ethanoic anhydride (<b>Corrosive</b>) provides a safer alternate to the use of ethanoyl chloride (<b>Flammable, Corrosive</b>) in ethanoylation reactions.</p>	
10.7f	<b>26. The preparation and purification of <i>N</i>-phenylethanamide</b>		<b>Appendix 2</b>
	<p><b>Practical</b></p> <ul style="list-style-type: none"> <li>Determine the weight of a material using the weighing by difference method</li> <li>Handle hazardous materials safely</li> <li>Purify by recrystallisation</li> <li>Determine yield and melting point</li> <li>Estimate the purity of a product</li> </ul>	<p>This exercise contains instructions for the preparation and purification of the product. It could be used independently, or as a follow-up experiment after the plan has been written (Experiment 25).</p> <p><b>Timing:</b> 1–1.5 hours</p> <p><b>Note:</b> The syllabus requires students to show an understanding of the chemistry of acyl chlorides. Given the hazards associated with this class of compound, the use of ethanoic anhydride (<b>Corrosive</b>) provides a safer alternate to the use of ethanoyl chloride (<b>Flammable, Corrosive</b>) in ethanoylation reactions.</p>	

## Appendix 1

Syllabus section	Skills/Learning Outcomes	Notes	Sources
10.8a, 10.8d, 10.8e, 10.8f, 11.3c, 11.3d	<p><b>27. Addition polymerisation – preparation of polystyrene / poly(phenylethene)</b></p> <ul style="list-style-type: none"> <li>• Handling hazardous materials safely</li> <li>• Compare the properties of materials and suggest reasons for the differences</li> <li>• Understand the polymerisation process</li> </ul>	<p>Alkenes (carbon compounds containing double bonds) undergo addition reactions. In this experiment, molecules of phenylethene (styrene), the monomer, add on to each other to form poly(phenylethene) (polystyrene), the polymer.</p> <p>This experiment is only suitable for <b>extremely able</b> students; it may be better to demonstrate it.</p> <p>Generally, addition polymerisation is difficult to demonstrate, so it is <b>essential</b> to trial this experiment before showing it to the class. The quality of the product will be poor compared to commercially produced material; this could provide a useful discussion point.</p> <p><b>Note:</b> Most styrene samples contain an inhibitor that <b>must</b> be removed by washing with 1 mol dm<sup>-3</sup> sodium hydroxide solution (<b>Corrosive</b>), then water, in a separating funnel. The styrene is dried for 10 min. using anhydrous sodium sulphate.</p> <p><b>Procedure</b></p> <p>Wear eye protection. Work in a <b>fume cupboard</b> or ensure good ventilation, as styrene vapour is <b>narcotic</b> in high concentrations.</p> <ol style="list-style-type: none"> <li>1. Add 0.1 g of di(dodecanoyl) peroxide (<b>Irritant</b>) to 5 cm<sup>3</sup> of phenylethene (<b>Highly flammable</b>) in a boiling tube.</li> <li>2. Put a bung, containing a 20 cm length of glass tubing, in the boiling tube and clamp the boiling tube in a <b>boiling</b> water-bath. The bottom of this tube, which serves as an air condenser, should be positioned well away from the surface of the reaction mixture.</li> </ol>	<p><i>Classic Chemistry Experiments</i>, The Royal Society of Chemistry – Experiment 95</p>

## Appendix 1

Syllabus section	Skills/Learning Outcomes	Notes	Sources
		<p>3. Heat for about 30 min and leave to cool. <b>Extinguish all flames.</b></p> <p>4. Pour the contents of the tube into 50 cm<sup>3</sup> of ethanol (<b>Flammable</b>).</p> <p>5. Use a glass rod to push the poly(phenylethene) into a lump and pour off the ethanol.</p> <p>Dry the solid on a filter paper and compare the appearance of the product with that of the starting material.</p> <p><b>Timing:</b> 1 hour</p>	

## Appendix 1

Syllabus section	Skills/Learning Outcomes	Notes	Sources
10.8a, 11.3c, 11.3d	<p><b>28. Polymer slime</b></p> <ul style="list-style-type: none"> <li>• Test chemical and physical characteristics</li> <li>• Revise the formation of addition polymers</li> <li>• Understand cross-linking by hydrogen bonding</li> <li>• Understand the effect that the addition of acid or alkali has on the cross-linked system</li> </ul>	<p>This exercise involves the formation, physical and chemical testing of a cross-linked polymer. It is also good fun to do!</p> <p>Polyvinyl alcohol (PVA) is a linear polymer. Its chains contain many hydroxy (OH) groups, which make it soluble in water. Borax, <math>B(OH)_3</math>, reacts reversibly with water to form <math>B(OH)_4^-</math>, which is able to react with PVA forming cross-links between two PVA chains. Mixing solutions of PVA and borax produces a cross-linked polymeric material called 'Polymer Slime' which has some novel properties.</p> <p><b>Process</b></p> <ol style="list-style-type: none"> <li>1. <b>PVA solution:</b> Add hydrated polyvinyl alcohol (40 g) to 1 dm<sup>3</sup> of water at 50 °C and heat, with stirring to 90 °C; or use a commercial PVA adhesive.</li> <li>2. <b>Borax solution:</b> Add borax (40 g) to 1 dm<sup>3</sup> of water.</li> <li>3. Add 40 cm<sup>3</sup> of PVA solution to 10 cm<sup>3</sup> of aqueous borax. Stir vigorously until gelling is complete.</li> </ol> <p>If wished, one drop of food colouring or fluorescein could be added to the PVA prior to mixing.</p> <p><b>Testing</b></p> <ol style="list-style-type: none"> <li>1. Test the slime under tension by first pulling it apart slowly, and then sharply/quickly. Also, form it into a ball and test its bouncing properties, and strike a small piece with the hand to test its response under impact.</li> </ol>	<p><i>Classic Chemistry Experiments,</i> The Royal Society of Chemistry – Experiment 77</p>

## Appendix 1

Syllabus section	Skills/Learning Outcomes	Notes	Sources
		2. Press a piece of the slime onto a sample of handwriting. 3. Add 0.4 mol dm <sup>-3</sup> hydrochloric acid ( <b>Corrosive</b> ) dropwise, while stirring. When a change is noticed, note the number of drops added and record your observations. 4. Add 0.4 mol dm <sup>-3</sup> sodium hydroxide ( <b>Corrosive</b> ) dropwise to the same sample used in 3 while stirring. When a change is noticed, record your observations. 5. Using the same sample, repeat parts 3 and 4 several times. 6. Suggest, in terms of acid/base equilibria, an explanation for the changes you observe. <b>Timing:</b> 1 hour <b>Note:</b> A fun experiment with some serious points to make about the dependence of polymeric properties on structure, on acid–base equilibria and on the pH dependence of hydrogen bonding.	
10.8, 11.3c	<b>29. Conducting polymers</b> <ul style="list-style-type: none"> <li>Handle hazardous materials safely</li> <li>Work with delicacy and precision</li> <li>Measure the conductivity of a polymer</li> <li>Understand the polymerisation process and the concept of a conducting polymer</li> </ul>	The exercise provides a novel way of preparing a polymer which, once formed, has unusual electrical properties. This is a relatively simple practical exercise but it does require great care and patience if it is to work properly. The chemicals used must be handled with care but the exercise is not beyond the capabilities of A level students. The polymer is formed at the anode of an electrolytic cell, with hydrogen gas being evolved at the cathode. <b>Timing:</b> at least 1 hour	<b>Appendix 2</b> This exercise is based on an experiment found in <i>Salter's Advance Chemistry</i> . PR4



## Appendix 1

Syllabus section	Skills/Learning Outcomes	Notes	Sources
11.1	<p><b>30. Extraction of DNA from frozen peas</b></p> <ul style="list-style-type: none"> <li>Extract DNA from a biological sample</li> </ul>	<p>This is a simple but effective method of isolating DNA from peas. First the tissue is broken up mechanically. Household detergent is then used to degrade the cell and nuclear membranes, causing the membrane phospholipids and proteins to precipitate. Sodium ions from table salt cause the DNA molecules to coalesce. Heating the mixture at 60 °C partially denatures enzymes that would otherwise start to degrade the DNA into fragments. Cell fragments are separated by filtration leaving a solution containing nucleic acids and soluble protein, which is cooled in order to slow down the breakdown of DNA. A protease is then used to partially break down the soluble proteins; the nucleic acids are then precipitated into <b>ice-cold ethanol</b>. Keep the ethanol in a plastic bottle in a freezer overnight or stand it in an ice bath for several hours before use.</p> <p><b>Procedure</b></p> <ol style="list-style-type: none"> <li>Dissolve 3 g of table salt in 90 cm<sup>3</sup> of distilled water in a 250 cm<sup>3</sup> beaker; add 10 cm<sup>3</sup> of washing-up liquid ('watery' not concentrated type) and mix gently.</li> <li>Mash the peas (fresh or from frozen) using a glass rod; add the pulp to the beaker.</li> <li>Heat the beaker in a water-bath at 60 °C for exactly 15 minutes.</li> <li>Cool the mixture in an iced water bath for 5 minutes, stirring frequently, and then filter it into a second beaker; the filtrate contains DNA.</li> <li>Add 2–3 drops of <i>novozyme neutralse</i> (a protease) to about 10 cm<sup>3</sup> of the pea extract in a boiling tube and mix well.</li> </ol>	<p>The National Centre for Biotechnology Education (NCBE) publishes protocols in investigating plant DNA available from their website: <a href="http://www.ncbe.reading.ac.uk/">http://www.ncbe.reading.ac.uk/</a></p>

## Appendix 1

Syllabus section	Skills/Learning Outcomes	Notes	Sources
		<p>6. Very carefully pour 10 cm<sup>3</sup> of <b>ice-cold ethanol (Highly flammable)</b> down the side of the tube so that it forms a layer on top of the pea extract.</p> <p>7. Allow the tube to stand for several minutes. The DNA forms as a white precipitate in the clear alcohol layer.</p> <p><b>Timing:</b> Isolating the DNA takes about 35 minutes.</p>	
11.2a, 11.2c, 11.2f, 11.2g	<p><b>31. Separation techniques</b></p> <ul style="list-style-type: none"> <li>• Use solvent extraction techniques and purify by recrystallising</li> <li>• Perform a titration and use a separating funnel</li> <li>• Determine a partition coefficient</li> <li>• Use and understand paper chromatography</li> <li>• Use and understand <b>two-way</b> chromatography</li> <li>• Use and understand electrophoresis</li> <li>• Understand amino acid structure and zwitterions</li> </ul>	<p>This exercise contains a suite of four experiments designed to give practice in a range of separation techniques. The basic techniques involved are relatively straightforward but great emphasis must be placed on safety, as there are hazards associated with several of the solvents used. In some cases, the use of a fume cupboard is necessary.</p> <p>The experiments may be performed as a circus, perhaps over several weeks. If fume cupboard facilities are limited, it may be better to perform the experiments separately, so that attention can be focussed on one process at a time. The use of demonstrations might be considered; however, a hands-on approach will make the techniques more memorable to the students.</p> <p><b>Timing:</b> a suite of exercises better done as a circus – allow 1 hour (at least) for each exercise.</p>	<b>Appendix 2</b>

## Appendix 1

Syllabus section	Skills/Learning Outcomes	Notes	Sources
11.3f, 11.3g	<p><b>32. Making 'Biodiesel' from rape seed oil</b></p> <ul style="list-style-type: none"> <li>Compare the combustion properties of materials and their implications for large scale use</li> <li>Appreciate the scale of the problem of replacing conventional fuels</li> <li>Handle hazardous materials safely</li> </ul>	<p>Biodiesel, a mixture of methyl esters of fatty acids, can be made very easily from a cooking oil made from rape seed, though other cooking oils may be tried. Enough biodiesel can be produced in an hour to burn, but it would not be pure enough to use in an engine. This experiment could be a starting point for further student investigations.</p> <p>A cooking oil, methanol and potassium hydroxide (a catalyst) are mixed. The resulting reaction (transesterification) produces biodiesel and glycerol as two layers. The biodiesel (top layer) is removed and washed with water to remove potassium hydroxide.</p> <p>The combustion characteristics of biodiesel can be compared with those of fossil diesel by drawing the gaseous reaction products through mineral wool (to trap particulates and test for 'sootiness') and a solution of universal indicator (to test for acidity) using a water pump.</p> <p><b>Procedure</b></p> <p><b>Stage 1</b></p> <ol style="list-style-type: none"> <li>Weigh about 100 g of rapeseed oil into a conical flask.</li> <li>Carefully add 15 g of methanol (<b>Toxic, Highly Flammable</b>).</li> <li>Slowly add 1 g of a 50% (50 g per 100 cm<sup>3</sup> of solution) potassium hydroxide solution (<b>Corrosive</b>).</li> </ol> <p><b>Note:</b> The chemicals can be added directly into a conical flask on a top pan balance (zero the balance after each addition).</p> <ol style="list-style-type: none"> <li>Stir or swirl for 10 min.</li> </ol>	<p><i>Materials</i>, The Royal Society of Chemistry – Pages 21–36 plus worksheets</p> <p>The booklet <i>Introducing Biodiesel</i> provides the background to the process</p>

## Appendix 1

Syllabus section	Skills/Learning Outcomes	Notes	Sources
		<p><b>Stage 2</b></p> <ol style="list-style-type: none"> <li>1. Centrifuge the mixture for one minute (you will need several centrifuge tubes to deal with the quantity). If a centrifuge is not available, you should leave the mixture to settle until layers form; this will take some time.</li> <li>2. Decant the top layers into a boiling tube and discard the lower layers.</li> <li>3. Wash the product by adding 10 cm<sup>3</sup> of distilled water to this top layer, with gentle mixing. (<b>Do not shake</b> the mixture).</li> <li>4. Repeat steps 1 and 2 once more.</li> <li>5. Keep your product for further investigation.</li> </ol> <p><b>Timing:</b> 1 hour</p>	

## Appendix 2 – Detailed practical lessons

### 1. Electrochemical cells and chemical change

#### Student Sheet

In this exercise, you will construct electrochemical cells and measure their e.m.f. values. You will compare your results with the results of test tube reactions, and investigate the effect of changing cell conditions.

#### Intended lesson outcomes

By the end of this exercise you will be able to

- set up an electrochemical cell
- read a voltmeter
- record observations from test tube experiments
- compare results from different types of experiment
- write cell descriptions and calculate  $E_{\text{cell}}$

#### Background information

Normally, for two species to react together it is necessary for them to collide with each other. So, when zinc metal is placed in aqueous copper sulphate a redox reaction occurs when the  $\text{Cu}^{2+}$  ions collide with the zinc metal. The redox reaction is exothermic and so heat energy is also evolved. The ionic equation for this reaction is given below.

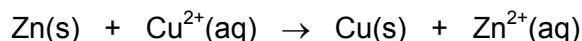

In this reaction, Zn atoms lose electrons (they are **oxidised**, and so zinc acts as a **reducing agent**).

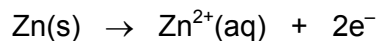

At the same time,  $\text{Cu}^{2+}$  ions gain electrons (they are **reduced**, and so are acting as an **oxidising agent**).

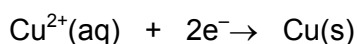

## Appendix 2

During the collision, electrons are transferred **directly** from zinc atoms to  $\text{Cu}^{2+}$  ions. If zinc metal is used as the electrode in one half of an electrochemical cell, and  $\text{Cu}^{2+}$  ions are present in the other half-cell, exactly the same reaction can occur. However, in order for the electron transfer to take place, electrons travel from the zinc atoms to the  $\text{Cu}^{2+}$  ions **via a metal wire**. In this case, most of the energy released by the reaction is obtained in the form of an electric current flowing in the wire.

The diagram below shows an electrochemical cell between zinc and copper. A strip of zinc foil is placed in a solution containing zinc ions, and a strip of copper is placed in a solution of copper ions. The two metals are joined by wire, and a salt bridge (e.g. a strip of filter paper soaked in saturated potassium nitrate solution) completes the circuit.

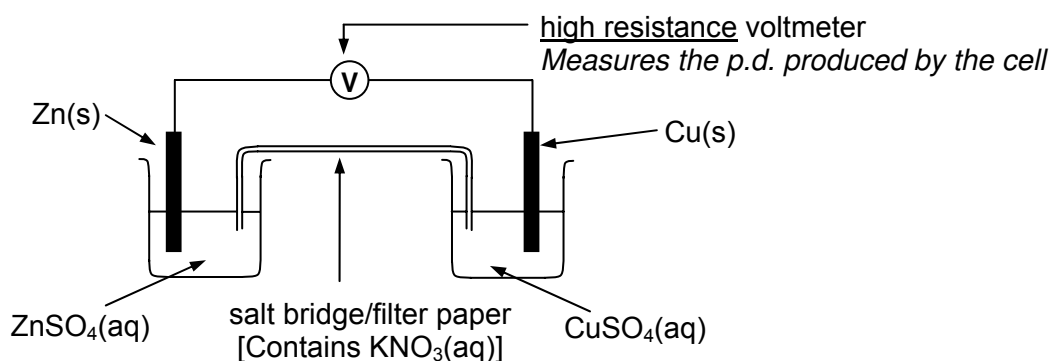

The zinc, being the more reactive metal, releases electrons more easily than copper. The electron density on the zinc foil is, therefore, higher than that on the copper foil. Electrons then flow from the area with higher electron density to the area with lower electron density. Thus, the zinc foil is the **negative pole** (relatively higher electron density), and the copper is the **positive pole** (relatively lower electron density) of this cell.

The cell works because of the **difference** in electron densities on each pole. The greater this difference, the larger the potential difference (p.d.) produced. It is, therefore, the **chemistry** of the process that determines the value of the p.d. of a cell. Increasing the **size** of the pieces of foil would increase the ability of the cell to pass electricity, so **allowing a larger current** to flow, but would have **no effect** on the p.d. produced. A cell would produce its maximum p.d. when no current is flowing. This is known as the *electromotive force*, i.e. the e.m.f. of the cell, or the Standard Cell Potential,  $E^\ominus_{\text{cell}}$ .

When working, a cell does not produce this maximum value, so we refer to measure the p.d. of a cell, rather than its e.m.f. value. When **measuring** a p.d. we use a **high resistance voltmeter**, the purpose of which is to reduce the current flow as near to zero as we can. The p.d. measured is then as close to the e.m.f. as we can get.

Instead of drawing each cell out in full, as above, by convention we can write a **Cell Description**. A *cell description* shows on its **left hand side** the chemical change occurring in the half-cell at the **negative pole**. On its **right hand side**, the chemical change occurring in the half-cell at the **positive pole** is shown.





The cell description of the above cell is shown below.



- The **single line** ' | ' placed between the two species indicates that they are in different phases (solid metal and aqueous ions in this case).
- The order of writing the species is: reactant | product.
- The **double line** between the two half-cells represents the **salt bridge**.

## Safety

Materials safety data sheets should be consulted so that the correct action can be taken in event of a spillage and/or accident.

	<b>You must wear eye protection throughout this experiment</b>
	Potassium nitrate is <b>oxidising</b>
	Copper sulphate and zinc sulphate are <b>irritants</b> Iron(II) sulphate and iron(III) chloride are <b>harmful</b>
	Silver nitrate is <b>corrosive</b>
	Copper sulphate, zinc sulphate and silver nitrate are <b>dangerous for the environment</b> . Your teacher will tell you how to dispose of these

## Procedure

**This exercise is designed to show the link between** what could be called **direct redox reactions**, when reactants are mixed together, and the **indirect** redox reactions that occur in an electrochemical cell.

### Experiment 1

1. Clean the pieces of metal with wire wool or sand paper to remove any surface coating. Treat the silver gently and only scour if it is not shiny.
2. Perform test tube reactions for each of the metal and salt combinations shown in the table below. After each test examine the surface of the metal to see if there is any change in its appearance, which would suggest that a reaction has taken place.
3. Record your observations in the table.

metal/salt	Cu	Zn	Ag
<b>CuSO<sub>4</sub></b>	X		
<b>ZnSO<sub>4</sub></b>		X	
<b>AgNO<sub>3</sub></b>			X

**Questions on Experiment 1**

For those experiments in which a **change is observed**:

- 1 Write an ionic equation for the overall reaction.
- 2 Write half-equations (ion–electron equations) for the oxidation and the reduction process.
- 3 From these half-equations, deduce what is being oxidised and what is being reduced. Explain your answers.
- 4 Name the oxidising agent and the reducing agent in the reaction.

**Experiment 2**

All solutions used in **this** experiment must have metal ion concentrations of **0.10 mol dm<sup>-3</sup>**.

1. Set up the circuit as shown in the diagram on the previous page.
2. To complete the circuit for each cell, a salt bridge must be used. This can be a strip of filter paper soaked in saturated potassium nitrate solution. Use a **new salt bridge** each time.
3. Construct each of the cells given below and measure the p.d. produced with a voltmeter. You should test the copper/zinc cell **last**, as you will use this cell again in **Experiment 3**.
4. Connect the voltmeter so that it shows a **positive** value. We will call this the cell e.m.f.,  $E_{\text{cell}}$ .
5. **Note:** we do not use the standard symbol ( $E^{\ominus}_{\text{cell}}$ ), as the concentrations used in the half-cells are not 1.00 mol dm<sup>-3</sup>. However, as the concentrations in the half-cells are equal, the value obtained will not be that far away from the standard value.
6. In each case deduce the **polarity** of the cell (by noting which of the electrodes is connected to the **black** terminal of the voltmeter). This is the negative pole of the cell.
7. Record your results in the table below.
8. The cell description for the copper/zinc cell is written in for you. Write a cell description for the other two cells.

	cell description	$E_{\text{cell}} / \text{V}$	negative pole	direction of electron flow
copper/silver cell				from:- to:-
silver/zinc cell				from:- to:-
copper/zinc cell	$\text{Zn(s)} \mid \text{Zn}^{2+}(\text{aq}) \mid \mid \text{Cu}^{2+}(\text{aq}) \mid \text{Cu(s)}$			from:- to:-

- Compare the results from Experiment 2 with the results from the equivalent metal/salt combinations in Equation 1.

**Note**

The chemical changes taking place when a cell is producing a current are the same ones that took place in Experiment 1 so the equations will be the same.



**Questions on Experiment 2**

- 1 What can you deduce about the role of the half-cell which forms the negative pole of each cell?
- 2 State what is happening to each metal strip.
- 3 Write half-equations for the reaction in each half-cell.
- 4 Write an overall equation for the reaction occurring in each cell.
- 5 Use the standard electrode potential,  $E^\ominus$  data given below to calculate  $E^\ominus_{\text{cell}}$  values for each cell using the formula:

$$E^\ominus_{\text{cell}} = E^\ominus (\text{RHS}) - E^\ominus (\text{LHS})$$



- 6 Consider the cell:  $\text{Ag}(\text{s}) | \text{Ag}^+(\text{aq}) || \text{Zn}^{2+}(\text{aq}) | \text{Zn}(\text{s})$

Identify the test in Experiment 1 which has the same metal/salt combination as in this cell. Does this test work?

Identify the test in Experiment 1 in which metal/salt combination as in this cell is reversed. Does this test work?

Calculate the  $E_{\text{cell}}$  value for the cell using:  $E^\ominus_{\text{cell}} = E^\ominus (\text{RHS}) - E^\ominus (\text{LHS})$

By reference to this  $E_{\text{cell}}$  value, state whether the reaction in this cell is feasible or non-feasible. Explain your answer.

**Experiment 3**

Using the copper/zinc cell, replace the original copper sulphate solution, of concentration  $0.10 \text{ mol dm}^{-3}$ , with:

- (i) A solution of copper sulphate of concentration  $1.0 \text{ mol dm}^{-3}$
- (ii) A solution of copper sulphate of concentration  $0.010 \text{ mol dm}^{-3}$
- (iii) A solution of copper sulphate of concentration  $0.0010 \text{ mol dm}^{-3}$

In each case, measure and record the  $E_{\text{cell}}$  value obtained. Compare your results with your result from Experiment 2.

**Questions on Experiment 3**

- 1 What effect did diluting the copper sulphate solution have on the  $E^{\ominus}_{\text{cell}}$  value of the copper/zinc cell?
- 2 Using Le Chatelier's principle, state and explain what effect there will be on the electron density on the copper foil when the copper sulphate solution is diluted?
- 3 Using your answer to part 2, account for the variation in  $E^{\ominus}_{\text{cell}}$  value when the copper sulphate solution was diluted.
- 4 Predict, with explanation, the effect of diluting the zinc sulphate solution, while using copper sulphate solution of concentration  $1.0 \text{ mol dm}^{-3}$ .

**Experiment 4**

Prepare a sample of solution **A**, by thoroughly mixing together  $5.0 \text{ cm}^3$  of aqueous  $\text{FeSO}_4$ , of concentration  $0.10 \text{ mol dm}^{-3}$  and  $5.0 \text{ cm}^3$  of aqueous  $\text{FeCl}_3$ , of concentration  $0.10 \text{ mol dm}^{-3}$ .

Perform the following tests.

- To a small amount of a solution of iodine in potassium iodide solution add a few drops of starch solution.
- Divide solution **A** into two portions.
- To the first portion of solution **A** add a few drops of starch solution.
- To the second portion of solution **A** add an equal volume of potassium iodide solution; then add a few drops of starch solution.

**Questions on Experiment 4**

It should be clear from your observations that a redox reaction took place when solution **A** was mixed with potassium iodide solution.

- 1 Identify the species that has been oxidised, and the species that has been reduced.
- 2 Write half-equations for the oxidation process and the reduction process.
- 3 Combine the half-equations to give an overall equation for the reaction.
- 4 Name the oxidising agent and the reducing agent.
- 5 Obtain appropriate standard electrode potential,  $E^{\ominus}$  data values from a data book and use them to calculate the  $E^{\ominus}_{\text{cell}}$  value for this feasible reaction.

## 1. Electrochemical cells and chemical change

### Teachers' Notes

Overall, the exercise provides a range of learning experiences for the student, which include: performing test tube redox reaction, constructing electrochemical cells and comparing the two sets of results obtained. It is possible that these experiments could be performed as a circus experiment. This would reduce the amount of equipment needed for the group.

#### Intended learning outcomes

Please see the Student Sheet.

#### A suggested approach

The aim of this exercise is to test or to develop the understanding students have of the operation of electrochemical cells, the construction of using different electrochemical cells, the effect of changing concentration on the Standard Cell Potential,  $E^{\circ}_{\text{cell}}$ , value and the use of Standard Electrode Potential,  $E^{\circ}$ , values in predicting the feasibility of reactions. You may need to remind your students that although conventionally we refer to current flowing from the positive pole to the negative pole, in reality, the electron flow is from negative to positive.

The experimentation should not take too long, but the students are likely to need a considerable amount of 'thinking time' to answer the questions posed in the exercise.

**Experiments 1 and 2** are linked, as the same redox reactions are involved in both. It would be worth spending a short time reviewing the basic theory involved, perhaps by reference to the Student Sheet.

It would be useful before **Experiment 3** is attempted to review the effect of concentration changes on equilibrium positions. Using Le Chatelier's principle students could be asked to predict the effect dilution would have on the electron densities on the metal foils and hence deduce the likely direction of change in  $E^{\circ}_{\text{cell}}$  values.

**Experiment 4** provides an opportunity for results to be analysed and an explanation for the redox reaction occurring to be deduced.

While the class is working on this exercise, you might like to 'entertain' them by growing a **silver tree!**

Using scissors, cut copper foil roughly into the shape of a tree with many small 'branches' (perhaps a Christmas tree if this is familiar to your students). Place it in a tall beaker and cover it with a well-diluted solution of silver nitrate. Silver crystals grow on the 'branches' and after some time hide the copper completely. The result is a rather pretty silver tree.

#### Answers to questions

##### Experiment 1

- 1 E.g.  $\text{Zn} + 2\text{Ag}^+ \rightarrow \text{Zn}^{2+} + 2\text{Ag}$
- 2 Oxidation:  $\text{Zn} \rightarrow \text{Zn}^{2+} + 2\text{e}^-$ ; Reduction:  $\text{Ag}^+ + \text{e}^- \rightarrow \text{Ag}$
- 3 Zn oxidised;  $\text{Ag}^+$  reduced
- 4 Oxidising agent = silver nitrate; Reducing agent = zinc sulphate

**Experiment 2**

- 1 It provides electrons so is the reducing agent
- 2 E.g. Zinc strip dissolves; silver is deposited on silver strip
- 3  $\text{Zn} \rightarrow \text{Zn}^{2+} + 2\text{e}^-$ ;  $\text{Ag}^+ + \text{e}^- \rightarrow \text{Ag}$
- 4  $\text{Zn} + 2\text{Ag}^+ \rightarrow \text{Zn}^{2+} + 2\text{Ag}$
- 5  $E^\ominus_{\text{cell}}(\text{Zn}/\text{Cu}^{2+}) = 1.10 \text{ V}$ ;  $E^\ominus_{\text{cell}}(\text{Zn}/\text{Ag}^+) = 1.56 \text{ V}$ ;  $E^\ominus_{\text{cell}}(\text{Cu}/\text{Ag}^+) = 0.46 \text{ V}$
- 6 Same combination =  $\text{Ag}(\text{s})/\text{Zn}^{2+}$  (doesn't work)  
 Reversed combination =  $\text{Zn}(\text{s})/\text{Ag}^+$  (does work)  
 $E^\ominus_{\text{cell}}(\text{Ag}/\text{Zn}^{2+}) = -1.56 \text{ V}$ ; reaction non-feasible as  $E^\ominus_{\text{cell}}$  is negative – reverse reaction feasible

**Experiment 3**

- 1 Diluting  $\text{Cu}^{2+}$  **lowered**  $E_{\text{cell}}(\text{Zn}/\text{Cu}^{2+})$
- 2  $\text{Cu}(\text{s}) \rightleftharpoons \text{Cu}^{2+}(\text{aq}) + 2\text{e}^-$ ; Lower  $[\text{Cu}^{2+}]$ ; equilibrium to right; increases  $\text{e}^-$  density on Cu foil
- 3 Difference in  $\text{e}^-$  density between two poles reduced;  $E^\ominus_{\text{cell}}(\text{Zn}/\text{Cu}^{2+})$  falls  
(opposite argument for increased  $[\text{Cu}^{2+}]$ )
- 4  $\text{Zn}(\text{s}) \rightleftharpoons \text{Zn}^{2+}(\text{aq}) + 2\text{e}^-$ ; Lower  $[\text{Zn}^{2+}]$ ; equilibrium to right; increases  $\text{e}^-$  density on Zn foil  
 Difference in  $\text{e}^-$  density between two poles increased;  $E^\ominus_{\text{cell}}(\text{Zn}/\text{Cu}^{2+})$  rises

**Experiment 4**

- 1 Iodide ions oxidised,  $\text{Fe}^{3+}$  ions reduced
- 2 Oxidation:  $2\text{I}^- \rightarrow \text{I}_2 + 2\text{e}^-$ ; Reduction:  $\text{Fe}^{3+} + \text{e}^- \rightarrow \text{Fe}^{2+}$
- 3  $2\text{Fe}^{3+} + 2\text{I}^- \rightarrow 2\text{Fe}^{2+} + \text{I}_2$
- 4 Oxidising agent = Iron(III) ion/chloride; Reducing agent = potassium iodide / iodide ions
- 5  $E^\ominus_{\text{cell}} = (+0.77) - (+0.54) = +0.23 \text{ V}$

## Technical information

### Requirements per student/group

- **Note:** it is only necessary to make up a sufficient volume of each solution to meet the needs of the class. For example, if the exercise were to be performed as a circus, then 50 cm<sup>3</sup> of silver nitrate solution would be ample. In this case, students should be instructed not to throw the solutions away after Experiment 1 but to pass them on to another group. The metals should be rinsed with water before re-use and any deposit can be removed with wire wool.
- Eye protection
- Six test tubes
- Two 10 cm<sup>3</sup> measuring cylinders
- Distilled water bottle
- Three 100 cm<sup>3</sup> beakers
- Wires and crocodile clips
- Access to a high resistance voltmeter
- Filter paper cut into strips of sufficient length to join the two 100 cm<sup>3</sup> beakers
- Saturated potassium nitrate solution
- Strips of zinc, copper and silver of suitable size
- Wire wool / sand paper
- Two 100 cm<sup>3</sup> conical flasks
- Access to 1.0 mol dm<sup>-3</sup> copper sulphate solution (make by dissolving 250 g of hydrated copper sulphate in distilled water and make up to 1.0 dm<sup>3</sup>)
- 50 cm<sup>3</sup> of 0.10 mol dm<sup>-3</sup> copper sulphate solution (make by dilution)
- 50 cm<sup>3</sup> of 0.010 mol dm<sup>-3</sup> copper sulphate solution (make by dilution)
- 50 cm<sup>3</sup> of 0.0010 mol dm<sup>-3</sup> copper sulphate solution (make by dilution)
- 50 cm<sup>3</sup> of 0.10 mol dm<sup>-3</sup> zinc sulphate solution (make by dissolving 28.8 g of hydrated zinc sulphate in distilled water and make up to 1.0 dm<sup>3</sup>)
- 50 cm<sup>3</sup> of 0.10 mol dm<sup>-3</sup> silver nitrate solution (make by dissolving 16.98 g of silver nitrate (**Corrosive**) in distilled water and make up to 1.0 dm<sup>3</sup>)
- Access to 0.10 mol dm<sup>-3</sup> iron(II) sulphate solution (make by dissolving 27.8 g of hydrated iron(II) sulphate (**Harmful**) in 200 cm<sup>3</sup> of 1.0 mol dm<sup>-3</sup> sulphuric acid and make up to 1.0 dm<sup>3</sup> with distilled water)
- Access to 0.10 mol dm<sup>-3</sup> iron(III) chloride solution (make by dissolving 16.2 g of anhydrous iron(III) chloride (**Harmful**) in distilled water and make up to 1.0 dm<sup>3</sup>)
- Access to starch solution
- Access to approx. 0.50 mol dm<sup>-3</sup> potassium iodide solution (make by dissolving 83 g of potassium iodide in 1.0 dm<sup>3</sup> distilled water)

## Safety

The main points are included on the Student Sheet but it is the teacher's responsibility to ensure that a full risk assessment is carried out prior to the practical session. As there are some hazards associated with the solutions used, safety issues should be stressed, and use of eye protection made mandatory. MSDS sheets should be consulted so that the correct action can be taken in event of a spillage and/or accident. Materials that are dangerous to the environment should be disposed of according to local regulations.

## 2. Redox experiments

### Student Sheet

In this exercise, you perform simple redox reactions and, on the basis of your observations, deduce the relative oxidising abilities of a number of oxidising agents.

#### Learning outcomes

By the end of this exercise you will be able to:

- record colour changes accurately
- decide when to use a control experiment
- design tests to assess relative oxidising ability
- analyse a set of tabulated results and draw conclusions
- tabulate a set of conclusions
- write overall ionic equations from redox half equations
- deduce order of oxidising ability and the feasibility of reactions

#### The exercise

You will carry out a series of test-tube reactions to investigate the possible reactions between various oxidising agents and reducing agents. From your observations you will make deductions as to the relative oxidising strengths of a number of different species. Where your observations indicate that a reaction has occurred, you will write an ionic equation for this reaction by combining the appropriate redox half-equations.

**Note 1** In order to justify your deduction that a reaction has occurred, it is necessary to **show** that an observable **change** has occurred. To do this, you **must quote** what you observed both **before and after** the reaction takes place. (See example below).

**Note 2** When adding a coloured solution to a colourless solution, there will be a colour change to the colourless solution even if no reaction has occurred. This is because the colourless solution simply dilutes the coloured one. If the colour changes to a **different** or a **darker** colour, or the final mixture has **no colour** (the original colour having been bleached), a reaction has occurred.

To **prove** that a reaction has occurred, it is often necessary to perform a **control** experiment. To do this, you add the **same volume** of the coloured solution to **equal volumes** of pure water and your test sample. If the colour in your test sample is different to that in the control you can conclude that a reaction has occurred.

#### Background Information

A stronger oxidising agent will oxidise the reduced form of a weaker oxidising agent and will itself be reduced.

Consider the two oxidising agents *acidified sodium dichromate(VI)* and *iodine*. As it is traditional to show half-equations as **reduction processes**, their **reduction** half-equations are shown below:

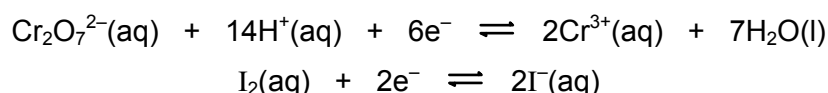

## Appendix 2

When an **orange solution** containing acidified dichromate ions is added to a **colourless solution** of iodide ions a **brown solution** is formed. When starch is added, the **brown solution** turns into a **blue-black solution**. This **change in colour** (orange to the darker colour – brown, or blue-black with starch) shows that iodine has been formed. Thus, iodide ions have been **oxidised** by the dichromate ions to iodine molecules while being **reduced** themselves to  $\text{Cr}^{3+}$  ions. The half-equations for these processes are:

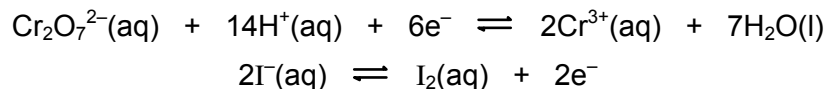

The overall equation for the reaction is obtained by adding together the two half-equations. When you do this, you must ensure that **the electrons MUST cancel out**, so that the final equation **does not contain electrons**. So, we need to multiply the iodide/iodine half-equation by three (6:2 electron ratio) so that there are six electrons in each half-equation. Added together they give the overall equation:

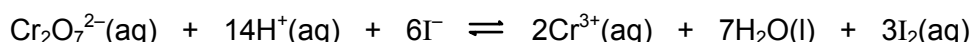

Since the dichromate ions have oxidised the iodide ions to iodine, we can conclude that the order of oxidising strength is:

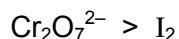











The reduction half-equations for the oxidising agents used in the tests which follow, are given below.

reduction half-equations (in random order)	
$\text{I}_2(\text{aq}) + 2\text{e}^- \rightleftharpoons 2\text{I}^-(\text{aq})$	$\text{S}_4\text{O}_6^{2-} + 2\text{e}^- \rightleftharpoons 2\text{S}_2\text{O}_3^{2-}$
$\text{Cl}_2(\text{aq}) + 2\text{e}^- \rightleftharpoons 2\text{Cl}^-(\text{aq})$	$\text{Br}_2(\text{aq}) + 2\text{e}^- \rightleftharpoons 2\text{Br}^-(\text{aq})$
$\text{Fe}^{3+}(\text{aq}) + \text{e}^- \rightleftharpoons \text{Fe}^{2+}(\text{aq})$	$\text{MnO}_4^-(\text{aq}) + 8\text{H}^+(\text{aq}) + 5\text{e}^- \rightleftharpoons \text{Mn}^{2+}(\text{aq}) + 4\text{H}_2\text{O}(\text{l})$
$\text{ClO}^-(\text{aq}) + \text{H}_2\text{O}(\text{l}) + 2\text{e}^- \rightleftharpoons \text{Cl}^-(\text{aq}) + 2\text{OH}^-(\text{aq})$	

## Safety

There are potentially hazardous substances involved in this exercise. You **must** follow all health and safety instructions given to you by your teacher. Materials safety data sheets should be consulted so that the correct action can be taken in event of a spillage and/or accident.

	<b>You must wear eye protection throughout this experiment</b>
	Iron(III) chloride, iron ammonium sulphate and potassium thiocyanate are <b>harmful</b>
	Sodium chlorate and potassium manganate are <b>oxidising</b>
	and <b>harmful</b>
	Bromine is <b>toxic</b>
	and <b>corrosive</b>
	Hydrochloric acid and sulphuric acid are <b>corrosive</b>
	Hexane is <b>highly flammable</b>
	and <b>harmful</b>
	Chlorine gas is <b>toxic</b>
	Bromine, potassium manganate and hexane are <b>dangerous for the environment</b> . Your teacher will tell you how to dispose of these.

## Procedure

- Using a clean test-tube each time, carry out the tests given in the table on the next page, making sure each time that the contents of the test-tube are thoroughly mixed before making your observations.
- For each test, record your observations **clearly, concisely** and **precisely** in the table. Note where you used a control experiment.
- When you have completed tests 1 - 9 in the table, devise and perform other tests to compare the oxidising strength of the chlorate(I),  $\text{ClO}^-(\text{aq})$ , ion against iron(II),  $\text{Fe}^{2+}(\text{aq})$ , ions and against bromide,  $\text{Br}^-(\text{aq})$ , ions.
- Continue the table to record brief details of the tests you performed and the observations you made in part 3.



**Analysis and evaluation**

Complete the table by:

1. Writing an ionic equation for any reactions that have occurred. If you have concluded that 'no reaction' has occurred, clearly there will be no equation to write.
2. In the 'Deductions' column, state in words which reagent has oxidised which other reagent. For example, in the reaction of  $\text{Cr}_2\text{O}_7^{2-}(\text{aq})$  ions and  $\text{I}^-(\text{aq})$  ions described above, you would write ' $\text{Cr}_2\text{O}_7^{2-}(\text{aq})$  ions oxidise  $\text{I}^-(\text{aq})$ '
3. Also in the deductions column, state which of the two oxidising agents present in the solution is the more powerful. For example, in the reaction of  $\text{Cr}_2\text{O}_7^{2-}(\text{aq})$  ions and  $\text{I}^-(\text{aq})$  ions, you would write ' $\text{Cr}_2\text{O}_7^{2-}(\text{aq}) > \text{I}^-(\text{aq})$ '
4. Arrange the oxidising agents you have used, include chlorate(I), in order of decreasing oxidising ability (strongest oxidising agent first).
5. Create a table to show, separately, the name, formula, reduction half-equation and Standard Electrode Potential,  $E^\ominus$ , value of each oxidising agent. Your table should show the oxidising agents you have used in order of decreasing oxidising ability (strongest oxidising agent first).
6. Obtain, from a data book, the  $E^\ominus$  value for each oxidising agent and add these data to your table.
7. Explain, in terms of their  $E^\ominus$  values, the order of the oxidising agents in your table.

**The following questions concern Tests 3 & 4**

- 1 Ask your teacher to check, and if necessary correct, your deductions for Tests 3 & 4.
- 2 Write cell descriptions for the redox system present in Test 3, where  $\text{Fe}^{2+}(\text{aq})$  is mixed with  $\text{Cl}_2(\text{aq})$ , and the redox system present in Test 4, where  $\text{Fe}^{2+}(\text{aq})$  is mixed with  $\text{I}_2(\text{aq})$ .  
**Hint:** You should assume, in Test 3, that  $2\text{Fe}^{2+}(\text{aq})$  is converted into  $2\text{Fe}^{3+}(\text{aq})$ , and that  $\text{Cl}^-(\text{aq})$  is converted into  $\text{Cl}_2(\text{aq})$ .  
 In Test 4, you should assume that  $2\text{Fe}^{2+}(\text{aq})$  is converted into  $2\text{Fe}^{3+}(\text{aq})$ , and that  $\text{I}^-(\text{aq})$  is converted into  $\text{I}_2(\text{aq})$ .
- 3 Use the  $E^\ominus$  values from your table to calculate the cell e.m.f,  $E^\ominus_{\text{cell}}$ , values for these two cells
- 4 On the basis of these  $E^\ominus_{\text{cell}}$  values, state and explain the feasibility of the cell reactions in Tests 3 and 4.

## Appendix 2

	Test	Observations	Ionic equation	Deduction
1	<b>iron(III) + aqueous iodide</b> Add about 8 drops of <b>iron(III)</b> solution to 1 cm <sup>3</sup> of aqueous <b>iodide</b> ions. Add a few drops of starch solution.			
2	<b>iron(III) + aqueous bromide</b> Add 2 cm <sup>3</sup> of aqueous <b>bromide</b> ions to 1 cm <sup>3</sup> of aqueous <b>iron(III)</b> ions. Add 1 cm <sup>3</sup> of hexane, cork, shake, and leave.			
3	<b>iron(II) + aqueous chlorine</b> Add 2 cm <sup>3</sup> of <b>aqueous chlorine</b> to 1 cm <sup>3</sup> of aqueous <b>iron(II)</b> ions. Observe any change, then add a few drops of potassium thiocyanate (KCNS) solution			
4	<b>iron(II) + aqueous iodine</b> Add about 4 drops of <b>aqueous iodine</b> to 1 cm <sup>3</sup> of aqueous <b>iron(II)</b> ions. Observe any change, then add a few drops of potassium thiocyanate (KCNS) solution			
5	<b>iron(II) + acidified manganate(VII)</b> Mix 1 cm <sup>3</sup> of aqueous MnO <sub>4</sub> <sup>-</sup> ions with 1 cm <sup>3</sup> of dilute sulphuric acid. Add, dropwise, 3 cm <sup>3</sup> of iron(II) solution. Observe any change. Add a few drops of potassium thiocyanate (KCNS) solution.			
6	<b>chlorine + bromide</b> Add about 1 cm <sup>3</sup> of aqueous chlorine to 1 cm <sup>3</sup> of aqueous bromide ions. Add about 1 cm <sup>3</sup> of hexane, cork, shake and leave.			

## Appendix 2

7	<b>bromine + iodide</b> Add about 1 cm <sup>3</sup> of aqueous bromine to 1 cm <sup>3</sup> of aqueous iodide ions. Add about 1 cm <sup>3</sup> of hexane, cork, shake and leave.			
8	<b>thiosulphate + iodine</b> Add aqueous sodium thiosulphate, dropwise, to 1 cm <sup>3</sup> of aqueous iodine until any change is complete			
9	<b>conc. HCl + manganate(VII)</b> <i>Working in a fume cupboard</i> , add 8 drops of conc. HCl to 1 cm <sup>3</sup> of aqueous MnO <sub>4</sub> <sup>-</sup> ions. Test any gas evolved with damp blue litmus paper			

## 2. Redox experiments

### Teachers' Notes

This exercise is very much 'hands-on' and, if the outcomes are clear and unambiguous, it provides considerable support in the development of a students' understanding of redox reactions, and of the use of standard electrode potentials in determining the feasibility of a proposed reaction.

#### Intended learning outcomes

Please see the Student Sheet

#### A suggested approach

Before your students undertake this exercise, they should have a reasonable basic understanding of redox reactions, standard electrode potentials, the calculation of cell e.m.f. values and the writing of cell descriptions. A brief review of these matters before they start the exercise will help to set the exercise in context.

The exercise makes use of simple test-tube reactions but, if sound results are to be obtained, each test must be performed with care and attention to detail.

Before starting the experiment, it is worth spending a little time reviewing the basic techniques of measuring and mixing. Students must not be allowed to mix the contents of a test-tube by inverting it while using a thumb as a bung! However, thorough mixing is essential if meaningful observations are to be made.

When students tackle the chlorate(I) investigation, it would be prudent to instruct them to show you their proposed tests before they perform them!

This exercise involves the use of potentially hazardous materials and so students should be closely supervised, unless they have considerable relevant practical experience.

#### Answer to questions

- The more positive the  $E^\ominus$  value, the more powerful the oxidising agent. The half-equation for the more positive species runs **forwards**, that for the less positive species runs **backwards**.
- Experiment 3  $\text{Pt} | \text{Fe}^{2+}(\text{aq}), \text{Fe}^{3+}(\text{aq}) || \text{Cl}_2(\text{aq}), \text{Cl}^-(\text{aq}) | \text{Pt}$   
Experiment 4  $\text{Pt} | \text{Fe}^{2+}(\text{aq}), \text{Fe}^{3+}(\text{aq}) || \text{I}_2(\text{aq}), \text{I}^-(\text{aq}) | \text{Pt}$
- Experiment 3  $E^\ominus = +1.36 - (+0.77) = +0.59 \text{ V}$   
Experiment 4  $E^\ominus = +0.54 - (+0.77) = -0.23 \text{ V}$
- Experiment 3  $E^\ominus = +\text{ve}$  reaction feasible as  $\Delta G = -\text{ve}$   
Experiment 4  $E^\ominus = -\text{ve}$  reaction not feasible as  $\Delta G = +\text{ve}$

#### The chlorate(I) investigation

Typically, the tests used to determine the oxidising strength of the chlorate(I) ion relative to bromine and  $\text{Fe}^{3+}(\text{aq})$  should be similar to:

#### Sodium chlorate(I) + bromide

Test	add about 1 cm <sup>3</sup> of aqueous sodium chlorate(I) to 1 cm <sup>3</sup> of aqueous bromide ions.
Observations	<i>colourless solutions throughout</i>
Inferences	'no reaction'; chlorate(I) does not oxidise $\text{Br}^-(\text{aq})$ ; $\text{Br}_2 > \text{ClO}^-$

## Appendix 2

**Iron(II) + sodium chlorate(I)**

Test Add about 1 cm<sup>3</sup> of aqueous sodium chlorate(I) to 1 cm<sup>3</sup> of aqueous iron(II) ions  
 Observations *colourless/pale green solution, turns brown*  
 Inferences 'reaction'; 'chlorate(I) oxidises Fe<sup>2+</sup>(aq)'; ClO<sup>-</sup> > Fe<sup>3+</sup>(aq)

**Expected deduction**

The oxidising strength of the chlorate(I) is **between** those of bromine and iron(II).

**Order of oxidising strengths**

<b>Oxidising agent</b>	MnO <sub>4</sub> <sup>-</sup>	Cl <sub>2</sub>	Br <sub>2</sub>	ClO <sup>-</sup>	Fe <sup>3+</sup>	I <sub>2</sub>	S <sub>4</sub> O <sub>6</sub> <sup>2-</sup>
<b>E° / V</b>	1.51	1.36	1.09	0.89	0.77	0.54	0.09

## Technical information

Requirements per student/group

### Apparatus

- Test-tubes and a test-tube rack
- Bungs/corks to fit test-tubes
- 10 cm<sup>3</sup> measuring cylinder
- Dropping pipettes
- Access to an organic waste bottle labelled **Hexane (Flammable)**

### Materials

Students will need access to the following:

- 0.5 mol dm<sup>-3</sup> (approximate) aqueous iron(III) chloride labelled **Fe<sup>3+</sup>(aq)**
- 0.5 mol dm<sup>-3</sup> (approximate) sodium thiosulphate labelled **S<sub>2</sub>O<sub>3</sub><sup>2-</sup>(aq)**
- 0.1 mol dm<sup>-3</sup> (approximate) aqueous potassium iodide labelled **I<sup>-</sup>(aq)**
- 10% aqueous sodium chlorate(I) labelled **sodium chlorate(I)(aq)**
- 0.1 mol dm<sup>-3</sup> (approximate) aqueous iron(II) ammonium sulphate labelled **Fe<sup>2+</sup>(aq)**
- 0.1 mol dm<sup>-3</sup> (approximate) aqueous potassium bromide labelled **Br<sup>-</sup>(aq)**
- 0.01 mol dm<sup>-3</sup> (approximate) aqueous iodine made by dissolving 2.5 g iodine and 8 g of potassium iodide in water and making the solution up to 1 dm<sup>3</sup> and labelled **I<sub>2</sub>(aq)**
- 0.1 mol dm<sup>-3</sup> (approximate) aqueous bromine solution labelled **Br<sub>2</sub>(aq)**
- 0.02 mol dm<sup>-3</sup> (approximate) aqueous potassium manganate(VII) labelled **MnO<sub>4</sub><sup>-</sup>(aq)**
- A solution made by diluting about 10 cm<sup>3</sup> of 10% aqueous sodium chlorate(I) to 100 cm<sup>3</sup> with water then adding 10 cm<sup>3</sup> of dilute (2 mol dm<sup>-3</sup>) hydrochloric acid and labelled **Cl<sub>2</sub>(aq)**  
Alternatively, chlorine water may be prepared by bubbling chlorine gas through deionised water for several hours (**in a fume cupboard**)
- Dilute sulphuric acid labelled **Dilute sulphuric acid**
- 0.5 mol dm<sup>-3</sup> (approximate) aqueous potassium thiocyanate labelled **KCNS(aq) (harmful)**
- Hexane
- 1% starch solution
- Access to concentrated hydrochloric acid
- Blue litmus paper

### Notes

The concentrations suggested are approximate and it may well be that existing solutions of different concentrations will be adequate. Teachers are advised to try out the tests in advance of the assessment exercise and to make any necessary adjustments.

In **Test 9** a precipitate of manganese(IV) oxide may well be observed but the expected equation does not suggest its formation. If necessary, tell your students that the only equation needed in Test 9 is that obtained by combining the two half equations listed.

### Safety

The main points are included on the Student Sheet but it is the teacher's responsibility to ensure that a full risk assessment is carried out prior to the practical session. As there are some hazards associated with the solutions used, safety issues should be stressed, and use of eye protection made **mandatory**. MSDS sheets should be consulted so that the correct action can be taken in event of a spillage and/or accident. Materials that are dangerous to the environment should be disposed of according to local regulations.

## Appendix 2

	test	observations	ionic equation	deductions
1	<b>iron(III) + aqueous iodide</b> Add about 8 drops of <b>iron(III)</b> solution to 1 cm <sup>3</sup> of aqueous <b>iodide</b> ions. Add a few drops of starch solution.	<ul style="list-style-type: none"> <li>• <i>yellow/pale brown solution</i></li> <li>• <i>added to colourless solution</i></li> <li>• <i>forms darker brown solution</i></li> <li>• <i>blue-black colour with starch</i></li> </ul>	$\text{Fe}^{3+}(\text{aq}) + 2\text{I}^{-}(\text{aq}) \rightleftharpoons 2\text{Fe}^{2+}(\text{aq}) + \text{I}_2(\text{aq})$	<p><math>\text{Fe}^{3+}(\text{aq})</math> oxidises <math>\text{I}^{-}(\text{aq})</math></p> <p><math>\text{Fe}^{3+}(\text{aq}) &gt; \text{I}_2(\text{aq})</math></p>
2	<b>iron(III) + aqueous bromide</b> Add 2 cm <sup>3</sup> of aqueous <b>bromide</b> ions to 1 cm <sup>3</sup> of aqueous <b>iron(III)</b> ions. Add 1 cm <sup>3</sup> of hexane, cork, shake, and leave.	<ul style="list-style-type: none"> <li>• <i>yellow/pale brown solution</i></li> <li>• <i>added to colourless solution</i></li> <li>• <i>no change</i></li> </ul>	No reaction	<p><math>\text{Fe}^{3+}(\text{aq})</math> does not oxidise <math>\text{Br}^{-}(\text{aq})</math></p> <p><math>\text{Fe}^{3+}(\text{aq})</math> not <math>&gt;</math> <math>\text{Br}_2(\text{aq})</math></p>
3	<b>iron(II) + aqueous chlorine</b> Add 2 cm <sup>3</sup> of <b>aqueous chlorine</b> to 1 cm <sup>3</sup> of aqueous <b>iron(II)</b> ions. Observe any change, then add a few drops of potassium thiocyanate (KCNS) solution	<ul style="list-style-type: none"> <li>• <i>colourless/pale green solution</i></li> <li>• <i>added to colourless solution</i></li> <li>• <i>pale yellow/green solution formed</i></li> <li>• <i>orange/red with KCNS</i></li> </ul>	$2\text{Fe}^{2+}(\text{aq}) + \text{Cl}_2(\text{aq}) \rightleftharpoons 2\text{Fe}^{3+}(\text{aq}) + 2\text{Cl}^{-}(\text{aq})$	<p><math>\text{Cl}_2(\text{aq})</math> oxidises <math>\text{Fe}^{2+}(\text{aq})</math></p> <p><math>\text{Cl}_2(\text{aq}) &gt; \text{Fe}^{2+}(\text{aq})</math></p>
4	<b>iron(II) + aqueous iodine</b> Add about 4 drops of <b>aqueous iodine</b> to 1 cm <sup>3</sup> of aqueous <b>iron(II)</b> ions. Observe any change, then add a few drops of potassium thiocyanate (KCNS) solution	<ul style="list-style-type: none"> <li>• <i>brown solution</i></li> <li>• <i>added to colourless/pale green solution</i></li> <li>• <i>no change (pale brown solution formed)</i></li> </ul>	No reaction	<p><math>\text{Fe}^{3+}(\text{aq})</math> does not oxidise <math>\text{Br}^{-}(\text{aq})</math></p> <p><math>\text{Fe}^{3+}(\text{aq})</math> not <math>&gt;</math> <math>\text{Br}_2(\text{aq})</math></p>
5	<b>iron(II) + acidified manganate(VII)</b> Mix 1 cm <sup>3</sup> of aqueous $\text{MnO}_4^{-}$ ions with 1 cm <sup>3</sup> of dilute sulphuric acid. Add, dropwise, 3 cm <sup>3</sup> of iron(II) solution. Observe any change. Add a few drops of potassium thiocyanate (KCNS) solution.	<ul style="list-style-type: none"> <li>• <i>colourless/pale green solution</i></li> <li>• <i>added to purple solution</i></li> <li>• <i>solution decolourised</i></li> <li>• <i>orange/red with KCNS</i></li> </ul>	$\text{MnO}_4^{-}(\text{aq}) + 5\text{Fe}^{2+}(\text{aq}) + 8\text{H}^{+}(\text{aq}) \rightleftharpoons \text{Mn}^{2+}(\text{aq}) + 5\text{Fe}^{3+}(\text{aq}) + 4\text{H}_2\text{O}$	<p><math>\text{MnO}_4^{-}(\text{aq})</math> oxidises <math>\text{Fe}^{2+}(\text{aq})</math></p> <p><math>\text{MnO}_4^{-}(\text{aq}) &gt; \text{Fe}^{3+}(\text{aq})</math></p>

## Appendix 2

6	<b>chlorine + bromide</b> Add about 1 cm <sup>3</sup> of aqueous chlorine to 1 cm <sup>3</sup> of aqueous bromide ions. Add about 1 cm <sup>3</sup> of hexane, cork, shake and leave.	<ul style="list-style-type: none"> <li>• colourless solution</li> <li>• turns yellow</li> <li>• hexane layer is darker yellow/brown</li> </ul>	$\text{Cl}_2(\text{aq}) + 2\text{Br}^-(\text{aq}) \rightleftharpoons \text{I}_2(\text{aq}) + 2\text{Cl}^-(\text{aq})$	$\text{Cl}_2(\text{aq})$ oxidises $\text{Br}^-(\text{aq})$  $\text{Cl}_2(\text{aq}) > \text{Br}_2(\text{aq})$
7	<b>bromine + iodide</b> Add about 1 cm <sup>3</sup> of aqueous bromine to 1 cm <sup>3</sup> of aqueous iodide ions. Add about 1 cm <sup>3</sup> of hexane, cork, shake and leave.	<ul style="list-style-type: none"> <li>• orange/red solution</li> <li>• added to colourless solution</li> <li>• turns darker yellow/brown</li> <li>• hexane layer is red/purple</li> </ul>	$\text{Br}_2(\text{aq}) + 2\text{I}^-(\text{aq}) \rightleftharpoons 2\text{Br}^-(\text{aq}) + \text{I}_2(\text{aq})$	$\text{Br}_2(\text{aq})$ oxidises $\text{I}^-(\text{aq})$  $\text{Br}_2(\text{aq}) > \text{I}_2(\text{aq})$
8	<b>thiosulphate + iodine</b> Add aqueous sodium thiosulphate, dropwise, to 1 cm <sup>3</sup> of aqueous iodine until any change is complete	<ul style="list-style-type: none"> <li>• colourless solution</li> <li>• added to brown solution</li> <li>• solution decolourised</li> </ul>	$2\text{S}_2\text{O}_3^{2-}(\text{aq}) + \text{I}_2(\text{aq}) \rightleftharpoons \text{S}_4\text{O}_6^{2-}(\text{aq}) + 2\text{I}^-(\text{aq})$	$\text{I}_2(\text{aq})$ oxidises $\text{S}_2\text{O}_3^{2-}(\text{aq})$  $\text{I}_2(\text{aq}) > \text{S}_4\text{O}_6^{2-}(\text{aq})$
9	<b>conc. HCl + manganate(VII)</b> <b>Working in a fume cupboard,</b> add 8 drops of conc. HCl to 1 cm <sup>3</sup> of aqueous $\text{MnO}_4^-$ ions. Test any gas formed with damp blue litmus paper	<ul style="list-style-type: none"> <li>• purple solution</li> <li>• brown colour (ignore reference to ppt)</li> <li>• litmus bleached</li> </ul>	$2\text{MnO}_4^-(\text{aq}) + 16\text{H}^+(\text{aq}) + 10\text{Cl}^-(\text{aq}) \rightleftharpoons 2\text{Mn}^{2+}(\text{aq}) + 8\text{H}_2\text{O}(\text{l}) + 5\text{Cl}_2(\text{aq})$	$\text{MnO}_4^-(\text{aq})$ oxidises $\text{Cl}^-(\text{aq})$  $\text{MnO}_4^-(\text{aq}) > \text{Cl}_2(\text{aq})$



## 5. Determination of the dissociation constant for a weak acid

### Student Sheet

This practical uses some of the skills you acquired at AS level, as well as reinforcing your understanding of indicator theory and the strengths of weak acids.

#### Intended lesson outcomes

At the end of this exercise you will be able to:

- use a pipette and a burette to produce solutions of different concentration
- prepare a buffer solution
- use and understand indicator theory
- calculate dissociation constants

#### Background information

The pH of an aqueous solution of a weak acid gives some indication of the strength of an acid, but the pH varies with concentration. Dissociation constants,  $E_a$  values, give a much more accurate guide to the actual strength of an acid because their values are unaffected by changes in concentration.

A weak acid dissolved in water dissociates by reacting with the water as shown in the equation below.

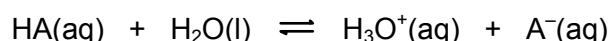

The  $K_c$  expression for this equilibrium process is:

$$K_c = \frac{[\text{H}^+(\text{aq})][\text{A}^-(\text{aq})]}{[\text{HA(aq)}][\text{H}_2\text{O}]}$$

As the concentration of water,  $[\text{H}_2\text{O}]$ , is so large compared to the other concentrations, it may be regarded as being constant, and so this equilibrium equation is often simplified as below

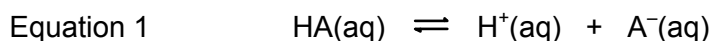

The dissociation constant for this reaction,  $K_a$ , is calculated using the expression shown below, where  $K_a = K_c \times [\text{H}_2\text{O}]$ .

$$K_a = \frac{[\text{H}^+(\text{aq})][\text{A}^-(\text{aq})]}{[\text{HA(aq)}]}$$

#### Indicators

Indicators are also weak acids, or weak bases. The dissociation of a weak acid indicator, such as *bromocresol green*, is similar to that of any other weak acid but is usually represented as below. In this equation, the undissociated indicator is represented by  $\text{HIn}$ , while the dissociated anion is shown as  $\text{In}^-$ .

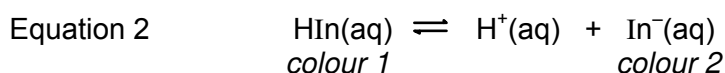

Excess acid drives the equilibrium to the left, while excess of alkali drives the equilibrium to the right. If a large excess of acid or alkali is added, *colour 1* or *colour 2* respectively is seen, otherwise an intermediate colour is seen. The colour observed will depend on the proportion of each the two colours present, i.e. the colour observed will depend on the  $[\text{In}^-]/[\text{HIn}]$  ratio.

## The experiment

In this experiment you will determine the dissociation constant of ethanoic acid in an ethanoic acid/sodium ethanoate buffer solution.



In the first step of this experiment you will dilute, to different extents, solutions containing bromocresol blue and either HCl or NaOH. These solutions will contain predominantly either HIn or  $\text{In}^-$ , the concentrations of which will depend on the degree of dilution used. By placing one test tube containing HIn in front of one containing  $\text{In}^-$ , and viewing through the two test tubes, a *combined* colour will be seen.

The combined colour observed will depend on the ratio of the concentrations of HIn and  $\text{In}^-$  in the two test tubes. If this same colour is observed in a sample of the buffer, the  $[\text{In}^-]/[\text{HIn}]$  ratio in the buffer will be the same as the  $[\text{In}^-]/[\text{HIn}]$  ratio between the two separate test tubes. For example, if tubes 3 and 12 in the table below give a combined colour the same as that of the buffer, then the  $[\text{In}^-]/[\text{HIn}]$  ratio in the buffer is 7:3. Once the ratio of  $[\text{In}^-]/[\text{HIn}]$  in the buffer solution is known, the value of  $K_a$  for ethanoic acid can be calculated.

**Note:** You may be more familiar with bromocresol blue as a titration indicator. The endpoint of a titration is reached when the two forms of the indicator are present in equal concentrations. Therefore, with bromocresol blue, the endpoint colour would be the colour observed when tubes 5 and 14 in the table below are viewed together.

## Safety

In step 1 of this exercise, concentrated solutions of hydrochloric acid and sodium hydroxide are used; both are hazardous. MSDS sheets should be consulted so that the correct action can be taken in event of a spillage and/or accident.

	<b>You must wear eye protection throughout this experiment</b>
	Ethanoic acid (glacial acetic acid), sodium hydroxide and concentrated hydrochloric acid are <b>corrosive</b>
	Ethanol is <b>Highly flammable</b>

## Method

1. Make up solutions **A** and **B** as described below. It is crucial that the amounts used are accurately measured. Use the same pipette to measure the acid and alkali. You must wash the pipette with the acid or alkali prior to use.

**Solution A:** Add one drop of concentrated HCl to 5 cm<sup>3</sup> of aqueous bromocresol green. In this form almost all the indicator is in the undissociated form, HIn. Mix the solution thoroughly.

**Solution B:** Add one drop of 4M NaOH to 5 cm<sup>3</sup> of aqueous bromocresol green. In this the indicator will be mainly dissociated as  $\text{In}^-$ . Mix the solution thoroughly.

## Appendix 2

2. Arrange 18 test tubes in an array of two parallel rows of 9, so that it will be possible to look straight through each pair to see the combined colour of each pair.

Number the tubes and make up the following solutions using a burette to measure the water and the same pipette to add the correct number of drops of **A** or **B**. These drops must be the same size. Mix all the solutions thoroughly.

tube number	1	2	3	4	5	6	7	8	9
volume of water (cm <sup>3</sup> )	10	10	10	10	10	10	10	10	10
drops of <b>A</b>	1	2	3	4	5	6	7	8	9

tube number	10	11	12	13	14	15	16	17	18
volume of water (cm <sup>3</sup> )	10	10	10	10	10	10	10	10	10
drops of <b>B</b>	9	8	7	6	5	4	3	2	1

3. Mix together 5.00 cm<sup>3</sup> of aqueous ethanoic acid, of concentration 0.0200 mol dm<sup>-3</sup>, and 5.00 cm<sup>3</sup> of aqueous sodium ethanoate, of concentration 0.0200 mol dm<sup>-3</sup>. This gives a buffer solution of ethanoic acid and sodium ethanoate in which the [CH<sub>3</sub>COOH] and [CH<sub>3</sub>COONa] are equal. Such a solution is said to be *equimolar*. To this buffer:
- add 10 drops of the original aqueous bromocresol green; mix thoroughly, then
  - compare the colour of this solution with that of the corresponding of pairs of test tubes in the array, then
  - identify the pair of test tubes in the array whose combined colour most closely matches the colour of the buffer solution.

### Calculation

**Note:** The ratio of [In<sup>-</sup>]/[HIn] in the buffer solution =  $\frac{\text{number of drops of B}}{\text{number of drops of A}}$

- 1 Write an expression, based on equation 2, for the  $K_{\text{In}}$  (i.e. the  $K_{\text{a}}$ ) of the indicator.
- 2 Use your  $K_{\text{In}}$  expression, together with your ratio of drops, to calculate the [H<sup>+</sup>] of the buffer solution.

(The  $K_{\text{a}}$  value for bromocresol green is  $2.00 \times 10^{-5}$  mol dm<sup>-3</sup>)

- 3 Write an equation for the dissociation of aqueous ethanoic acid.
- 4 Write a  $K_{\text{a}}$  expression, similar to the general one obtained from equation 1, for the dissociation of ethanoic acid.

Use this expression, together with your calculated value for the [H<sup>+</sup>] of the buffer solution, to deduce the  $K_{\text{a}}$  value for ethanoic acid.

- 5 Compare your value with the data book value for the dissociation constant of ethanoic acid, which is  $1.7 \times 10^{-5}$  mol dm<sup>-3</sup>.

## 5. Determination of the dissociation constant for a weak acid

### Teachers' Notes

It is common to deduce the  $K_a$  value for a weak acid by using a pH meter, as shown in Experiment 6. The approach adopted in this exercise is somewhat novel and provides a 'low technology' route to determining this value.

A number of solution pairs are prepared in which the concentrations of the undissociated indicator, HIn, or the anion from the dissociation of the indicator,  $\text{In}^-$ , are known. When viewed together, the combined colour observed is the same as that which would be observed when the two species are present in the same  $[\text{In}^-]/[\text{HIn}]$  ratio as the ratio between the two separate tubes. For example, if tubes 3 and 12 give a combined colour the same as that of the buffer, then the  $[\text{In}^-]/[\text{HIn}]$  ratio in the buffer is 7:3.

The exercise requires considerable care and patience in making up the different solutions, together with a sound understanding of chemical equilibria, but proves popular with students.

### Intended learning outcomes

These are detailed on the Student Sheet.

### Technical information

Requirements per student/group

- one test tube labelled 'solution **A**'
- one test tube labelled 'solution **B**'
- one test tube labelled 'buffer solution'
- 18 test tubes
- labels for the 18 test tubes
- one burette, clamp and stand
- two teat pipettes with undamaged tips
- sufficient test tube racks to form an array 9 tubes wide and 2 tubes deep
- access to a burette filled with aqueous ethanoic acid, of concentration  $0.0200 \text{ mol dm}^{-3}$
- access to a burette filled with aqueous sodium ethanoate, of concentration  $0.0200 \text{ mol dm}^{-3}$
- access to a burette filled with aqueous bromocresol green, made by dissolving 0.1 g in  $20 \text{ cm}^3$  of ethanol and making the solution up to  $100 \text{ cm}^3$  with water
- access to a supply of aqueous sodium hydroxide of concentration  $4.0 \text{ mol dm}^{-3}$ , labelled with the appropriate hazard symbol
- access to a supply of concentrated hydrochloric acid (approx  $8 \text{ mol dm}^{-3}$ ), labelled with the appropriate hazard symbol

### Safety

The main points are included on the Student Sheet but it is the teacher's responsibility to ensure that a full risk assessment is carried out prior to the practical session.

**Answers to the questions on the Student Sheet**

$$1 \quad K_a = \frac{[\text{H}^+(\text{aq})][\text{In}^-(\text{aq})]}{[\text{HIn}(\text{aq})]}$$

2 If the  $[\text{In}^-]/[\text{HIn}]$  ratio in the buffer were 7:3

$$[\text{H}^+(\text{aq})] = \frac{K_a \times [\text{HIn}(\text{aq})]}{[\text{In}^-(\text{aq})]} = \frac{2.00 \times 10^{-5} \times 3}{7}$$

$$= 8.57 \times 10^{-5} \text{ mol dm}^{-3}$$

3  $\text{CH}_3\text{COOH}(\text{aq}) \rightleftharpoons \text{H}^+(\text{aq}) + \text{CH}_3\text{COO}^-(\text{aq})$

$$4 \quad K_a = \frac{[\text{H}^+(\text{aq})][\text{CH}_3\text{COO}^-(\text{aq})]}{[\text{CH}_3\text{COOH}(\text{aq})]}$$

As the salt and acid concentrations have been chosen to be equal (both diluted to  $0.0100 \text{ mol dm}^{-3}$  upon mixing) they cancel. So:

$$K_a = [\text{H}^+(\text{aq})] = 8.57 \times 10^{-5} \text{ mol dm}^{-3}$$

## 9. Determination of the solubility product of $\text{KIO}_4$ and an investigation of the common ion effect

### Student Sheet

This experiment will allow you to calculate a value for  $K_{\text{sp}}$ , and also to see the common ion effect in operation.







#### Intended learning outcomes

At the end of this practical and its write up you should be able to:

- Make up standard solutions and prepare equilibrium mixtures
- Plot a graph
- Calculate concentrations and deduce  $K_{\text{sp}}$  values
- Calculate experimental errors and apparatus errors and use these to evaluate experimental accuracy
- Consider the implications of apparatus errors when undertaking a planning exercise.
- Understand the Common Ion Effect

#### Safety

Materials safety data sheets should be consulted so that the correct action can be taken in event of a spillage and/or accident.

	<b>You must wear eye protection throughout this experiment</b>
 	Sodium nitrate is <b>oxidizing</b> and <b>harmful</b>
	Potassium nitrate is <b>oxidizing</b>
 	Potassium iodate is <b>oxidising</b> and <b>irritant</b>
	Sulphuric acid is <b>corrosive</b> .

#### Background Theory

Potassium iodate(VII) is sparingly soluble in water (its saturated solution is about  $0.02 \text{ mol dm}^{-3}$ ).



## Appendix 2

Its solubility product is given by the expression:

$$K_{sp} = [K^+(aq)][IO_4^-(aq)] \quad \text{Equation 2}$$

Its solubility (call it "s") is related to  $K_{sp}$  as follows:

$$s = [KIO_4(aq)] = [K^+(aq)] = [IO_4^-(aq)]$$

$$\therefore K_{sp} = s^2 \quad \text{or} \quad s = \sqrt{K_{sp}}$$

### The Common Ion Effect

If either  $K^+$  ions or  $IO_4^-$  ions were to be added to the saturated solution of  $KIO_4$  then, by Le Chatelier's principle, Equilibrium 1 would be displaced to the left. This would produce more solid  $KIO_4$ , and so the solubility of  $KIO_4$  in this solution would be reduced. In other words, since the value of  $K_{sp}$  in Equation 1 is **constant**, if the  $[K^+]$  were increased (for example, by the addition of another potassium salt), the  $[IO_4^-]$  would *decrease* in order to keep  $K_{sp}$  the same. The ion which has been added, in this case the  $K^+$  ion, is termed the **Common Ion**, as it is the same as one of the ions present in  $KIO_3$ . The decrease in solubility, which results when a **common ion** is added to a saturated solution of a sparingly soluble salt, is called the **Common Ion Effect**.

There is just one complication: The solubilities of ionic compounds in water are dependent on how many other ions (ions that may be totally unrelated to those in the salt) are in solution. To avoid complicated calculations, this experiment is designed to keep the **ionic strength** of the solution constant, by using the inert salt sodium nitrate in just the right amounts.

### Basic principles

Solid potassium iodate(VII) is shaken with an aqueous mixture of  $NaNO_3$  and  $KNO_3$  (see table below) until equilibrium is reached. The excess solid is allowed to settle and the solution is filtered. A sample of the filtrate is taken, using a pipette, and its  $[IO_4^-]$  is measured by titration.

### Determining the concentration of $IO_4^-$ ions in the filtrate

When acid and an excess of potassium iodide are added to the sample of filtrate, iodine is produced according to the reaction shown below:



This solution of iodine is then titrated with a standard solution of sodium thiosulphate.

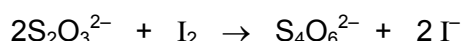

By considering both of the above equations, we can see that **1 mole** of  $IO_4^-$  is equivalent to **8 moles** of  $S_2O_3^{2-}$ . Thus, the  $[IO_4^-]$  may be deduced.

As the addition of  $KNO_3$  drives Equilibrium 1 to the left, the  $K^+$  ions present when a new equilibrium is established will be those from the  $KNO_3$  added, together with any  $K^+$  ions present from Equation 1.

### Method

This practical exercise is in two parts: part **A**, preparing the solutions prior to titration, and part **B**, performing the titrations. Part **A** may be done communally, but part **B** should be done individually or in pairs.

Obtain or prepare the following solutions:

**Sodium nitrate:** 500 cm<sup>3</sup> of 0.2 mol dm<sup>-3</sup> (dissolve 8.50 g of the solid in distilled water and make up to 500 cm<sup>3</sup> in a volumetric flask)

## Appendix 2

- Potassium nitrate** 250 cm<sup>3</sup> of 0.2 mol dm<sup>-3</sup> (dissolve 5.05 g of the solid in distilled water and make up to 250 cm<sup>3</sup> in a volumetric flask)
- Sodium thiosulphate** 0.0500 mol dm<sup>-3</sup> solution (this will be prepared for you)
- Potassium iodide** 1.0 mol dm<sup>-3</sup> solution (about 300 cm<sup>3</sup> may be needed in all)

**Part A – making up the mixtures**

- Take six 250 cm<sup>3</sup> bottles with stoppers. Weigh about 1 g of KIO<sub>4</sub> into each. Label them **A** to **F**.
- To each bottle add the appropriate quantities of aqueous sodium nitrate and aqueous potassium nitrate given in the table below. Use a 100 cm<sup>3</sup> measuring cylinder to measure out the NaNO<sub>3</sub> solutions. Use another 100 cm<sup>3</sup> measuring cylinder to measure out the KNO<sub>3</sub> solution for bottles **A** and **B**, but use a burette to measure out the KNO<sub>3</sub> solution for bottles **C** to **F**.

bottle	A	B	C	D	E	F
volume of NaNO <sub>3</sub> / cm <sup>3</sup>	0	50	75	90	95	100
volume of KNO <sub>3</sub> / cm <sup>3</sup>	100	50	25	10	5	0

- Place the stoppers tightly into the bottles and, keeping your finger over the stopper, shake each bottle for about 3–4 minutes to allow time for equilibrium to be reached. Allow the bottles to stand undisturbed until the excess solid mostly settles to the bottom. Try not to disturb the solid too much in the next step.
- Filter each solution through a dry, labelled, 250 cm<sup>3</sup> conical flask using a new dry filter paper each time. Place a 10 cm<sup>3</sup> pipette in or by each flask, and **do not mix them up during the subsequent titrations!**

**Part B – titrating the solutions**

- Fill a burette with the 0.0500 mol dm<sup>-3</sup> sodium thiosulphate solution.
- Using a pipette, transfer 10.0 cm<sup>3</sup> of solution **A** into a 100 cm<sup>3</sup> conical flask.
- Using **separate** measuring cylinders, transfer to this flask about 5 cm<sup>3</sup> of 1.0 mol dm<sup>-3</sup> KI and about 5 cm<sup>3</sup> of dilute sulphuric acid.
- Titrate the iodine produced in the solution with sodium thiosulphate from the burette, adding starch indicator near the endpoint (when the solution reaches a pale yellow colour).
- Repeat the above process with the solutions from all the other bottles, **using the bottle's own pipette each time, to avoid cross-contamination.**
- Your titre volumes should range from around 35 cm<sup>3</sup> down to about 2 cm<sup>3</sup>, depending on the bottle you are titrating. So, be careful you do not overshoot the end-point!
- Enter your results in the table below.
- Complete your table by calculating the values for the remaining six columns.

**Note:** The K<sup>+</sup> ions in each equilibrium solution come from two sources. Some are present in the KNO<sub>3</sub> solution added to each flask. The remainder come from the dissolved KIO<sub>4</sub>. The total [K<sup>+</sup>] is calculated by adding the [K<sup>+</sup>] from the KNO<sub>3</sub> solution used, to the [K<sup>+</sup>] from the dissolved KIO<sub>4</sub>. The latter [K<sup>+</sup>] will be the same as the [IO<sub>4</sub><sup>-</sup>]



## Appendix 2

$$\begin{aligned} \text{The } [K^+] \text{ from the } KNO_3 &= \frac{\text{volume of } KNO_3 \text{ added} \times [KNO_3]}{\text{total volume}} \\ &= \frac{\text{volume of } KNO_3 \text{ added} \times 0.200}{100} \end{aligned}$$

The  $[K^+]$  remaining from the saturated  $KIO_4 = [IO_4^-]$

$$\text{Total } [K^+] = [IO_4^-] + \frac{\text{volume of } KNO_3 \text{ added}}{500}$$

the  $K_{sp}$  value of the solution in each flask is calculated using  $K_{sp} = [K^+][IO_4^-] \text{ mol dm}^{-3}$

Flask	initial burette reading / $\text{cm}^3$	final burette reading / $\text{cm}^3$	volume of thiosulphate used / $\text{cm}^3$	moles of thiosulphate used / mol	moles of $IO_4^-$ in 10 $\text{cm}^3$ sample / mol	$[IO_4^-]$ / $\text{mol dm}^{-3}$	$[K^+]$ / $\text{mol dm}^{-3}$	$K_{sp}$ / $\text{mol}^2 \text{ dm}^{-6}$
A								
B								
C								
D								
E								
F								

### Analysis and evaluation of results

- Plot a graph of  $[IO_4^-]$  (i.e. the solubility) against  $[K^+]$ , drawing a line of best fit through your points. By considering the distribution of your plotted points around the line of best fit, comment on the quality of your results.
- Calculate the mean of the six  $K_{sp}$  values in your table.
- The data book value for the  $K_{sp}$  of  $KIO_4$  (at 298 K) is  $1.07 \times 10^{-2} \text{ mol}^2 \text{ dm}^{-6}$ . Calculate the difference between your mean  $K_{sp}$  value and the 'book' value. Express this difference as a percentage of the 'book' value. This is your total experimental error.
- Assuming that the maximum errors for the apparatus used in this experiment are as shown below, the total apparatus error is obtained by adding together the maximum percentage error in using each piece of apparatus.

You should use the titre to calculate the error in the burette and the volume of solution transferred in the pipette to calculate the error in the pipette.

$$\text{Pipette} = \pm 0.06 \text{ cm}^3$$

$$\text{Burette} = \pm 0.10 \text{ cm}^3 \text{ (from two readings)}$$

Select the experiment in your table whose  $K_{sp}$  value is closest to the 'book' value. Use the data from **this** experiment to calculate the total apparatus error for **this** experiment.

- By comparing the total experimental error with the total apparatus error, comment on the accuracy of **this** experiment.

## Appendix 2

- 6** Calculate the value of the total equipment error for Experiment **A** and for Experiment **F**.
- Explain why they are so different. Suggest why it would be unreasonable to expect the  $K_{sp}$  value obtained in experiment **A** to be as accurate as that obtained in experiment **F**.
  - What might be learned from this when planning the quantities and apparatus to be used in a quantitative investigation?
- 7** The range of titration results in your experiments **A** – **F**, will be wide. In terms of the Common Ion Effect, explain why this is so.

## 9. Determination of the solubility product of $\text{KIO}_4$ and an investigation of the common ion effect

### Teachers' Notes

#### Intended lesson outcomes

These are detailed on the pupil sheet.

#### Safety

The main points are included on the pupil sheet but it is the teacher's responsibility to ensure that a full risk assessment is carried out prior to the practical session.

#### Background Theory

Potassium iodate(VII) is sparingly soluble in water. (Its saturated solution is about  $0.02 \text{ mol dm}^{-3}$ .)

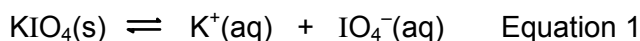

Its solubility product is given by the expression:

$$K_{\text{sp}} = [\text{K}^+(\text{aq})][\text{IO}_4^-(\text{aq})] \quad \text{Equation 2}$$

Its solubility (call it "s") is related to  $K_{\text{sp}}$  as follows:

$$s = [\text{KIO}_4(\text{aq})] = [\text{K}^+(\text{aq})] = [\text{IO}_4^-(\text{aq})]$$

$$\therefore K_{\text{sp}} = s^2 \quad \text{or} \quad s = \sqrt{K_{\text{sp}}}$$

You may need to emphasise that the above relationship,  $K_{\text{sp}} = s^2$ , only holds true when no additional common ions are present. In the presence of additional common ions, Equation 1 is driven to the left. This results in the concentration of the common ion will be greater than was present before the addition (because more has been added), while the concentration of the other ion will be less than it was originally as the equilibrium has moved to the left, and more  $\text{KIO}_4$  has precipitated. Thus,  $[\text{KIO}_4(\text{aq})] \neq [\text{K}^+(\text{aq})]$ , so  $K_{\text{sp}} = s^2$  fails. Equation 2 must now be used.

There is no real need to spend time discussing the significance of the ionic strength of a solution. Such a discussion will add little to the understanding of the class and may well cause confusion.

It is critical that the solutions are made up with precision and are allowed to come to equilibrium before use. The actual time required will depend on temperature and so the solutions should be left as long as possible before use.

Each sample should be filtered prior to use. Care must be exercised to prevent cross-contamination; so clean apparatus and a new filter paper should be used each time. The analysis of each filtrate is done by treating a  $10.0 \text{ cm}^3$  portion with excess aqueous potassium iodide and dilute sulphuric acid, and titrating the iodine produced against standard sodium thiosulphate solution. It might prove useful to review the chemistry involved in these processes before the experiment starts.

The analysis and evaluation of results section gives pupils the opportunity to practice their graphical skills but also requires them to evaluate their results critically. They should identify any anomalous points and interpret the scatter of their points relative to the best fit line to evaluate the reliability of their results (point 1).

## Appendix 2

The comparison of their mean  $K_{sp}$  value with the data book value (points 2 & 3) will give a measure of experimental accuracy. However, as each of the six experiments will have a different titre value, the total apparatus error will be different in each case. To overcome this problem, pupils are instructed to select the experiment that generates the  $K_{sp}$  value closest to the data book  $K_{sp}$  value (points 4 & 5). Here, as there is an actual titre value, the apparatus error can be calculated and the comparison between apparatus error and experimental error can be made.

Before the class tackles the errors analysis, it would be worth spending a little time reviewing this process. Assuming that the experimental error is greater than the total apparatus error, students should conclude that the additional error is caused by problems in the procedure used, or in the level of skill shown of the operator. You may wish to extend the exercise at this point by asking your students to identify the source(s) of these additional errors and to suggest steps that might be taken to eliminate or reduce them.

The aim of points 5 & 6 is to draw attention to the critical importance of the size of the titre value in determining the apparatus error. In experiment A, the titre will be small, as the high  $[KNO_3]$  will drive Equilibrium 1 strongly to the left (leaving a low  $[IO_4^-]$ ). The maximum burette error will, therefore, be high. The opposite argument applies in experiment E.

A discussion of this point with the class should result in sensible volumes being suggested when planning quantitative investigations.

Point 7 tests students' understanding of the Common Ion Effect.

### Technical Information

Requirements per student/group

#### Apparatus

- six 250 cm<sup>3</sup> bottles with stoppers
- access to a balance weighing to 0.01 g
- access to a burette containing aqueous potassium nitrate
- a burette to hold the sodium thiosulphate solution
- six 10 cm<sup>3</sup> pipettes – one only needed if it is washed between experiments
- filter papers and filter funnels
- one 500 cm<sup>3</sup> volumetric flask – not needed if NaNO<sub>3</sub>(aq) made up centrally
- one 250 cm<sup>3</sup> volumetric flask – not needed if KNO<sub>3</sub>(aq) made up centrally
- one 100 cm<sup>3</sup> conical flask
- two 10 cm<sup>3</sup> measuring cylinders
- two 100 cm<sup>3</sup> measuring cylinders

#### Chemicals

- about 10 g of solid sodium nitrate (or 500 cm<sup>3</sup> of 0.200 mol dm<sup>-3</sup> solution)
- about 6 g of solid potassium nitrate (or 250 cm<sup>3</sup> of 0.200 mol dm<sup>-3</sup> solution)
- about 10 g of solid potassium iodate(VII) [periodate]
- about 200 cm<sup>3</sup> of 0.0500 mol dm<sup>-3</sup> sodium thiosulphate solution
- about 100 cm<sup>3</sup> of 1.0 mol dm<sup>-3</sup> potassium iodide solution
- about 100 cm<sup>3</sup> of 1.0 mol dm<sup>-3</sup> sulphuric acid

#### Safety

The main points are included on the Student Sheet but it is the teacher's responsibility to ensure that a full risk assessment is carried out prior to the practical session. MSDS sheets should be consulted so that the correct action can be taken in event of a spillage and/or accident.

### 13. Experiments with enzymes – the effect of enzyme concentration on reaction rate

#### Student Sheet

In this experiment, you will investigate the effect of lipase concentration on the rate of hydrolysis of **glycerol triethanoate** (triacetin)

#### Intended lesson outcomes

By the end of this exercise you should be able to:

- handle small volumes of liquid
- deduce organic structures
- perform mole calculations
- analyse and evaluate your results

#### Background information

**Lipase** is an enzyme that breaks down, hydrolyses, the lipids present in animal fats and vegetable oils into propane-1,2,3-triol (glycerol) and long-chain carboxylic acids (fatty acids). These acids can be detected by following the drop in pH of the solution as the enzyme releases them. A general reaction scheme for this process is shown below; the size of the **R** group, and its level of saturation, will depend on the lipid used

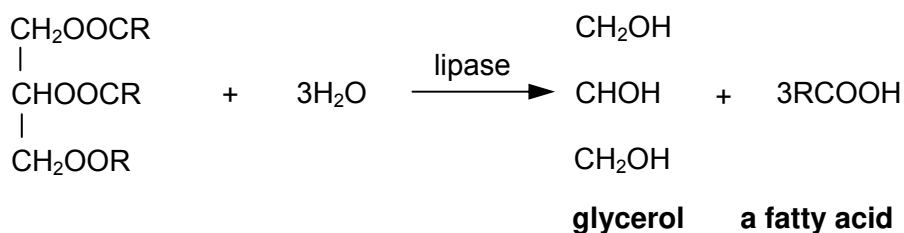

Olive oil is often used as a substrate in testing for lipase, with the oleic acid released being titrated with sodium hydroxide solution. Oleic acid,  $\text{C}_{17}\text{H}_{33}\text{COOH}$ , is a mono-unsaturated fatty acid.

In this exercise, glycerol triethanoate (triacetin) is used as the substrate. Lipase breaks this substrate down into glycerol and ethanoic acid as shown below.

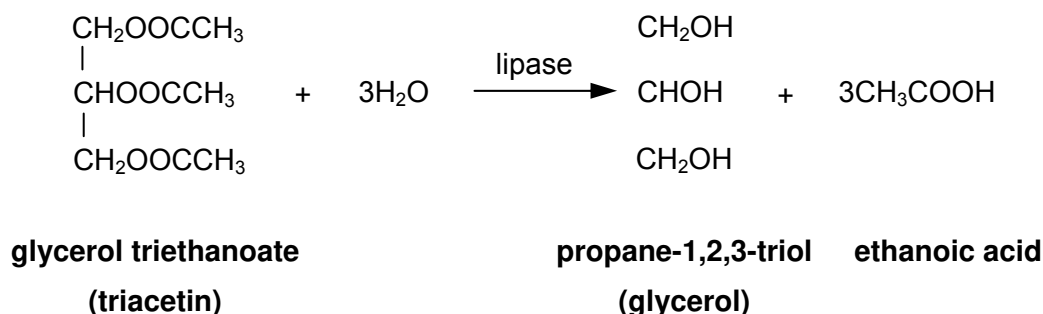



The ethanoic acid produced lowers the pH of the solution. This change can be detected by using a suitable acid-base indicator, in this case bromocresol purple which changes from purple at high pHs to yellow at lower pH values. Sodium carbonate is added to the triacetin to ensure that the pH is high enough at the start of the experiment. Only after the sodium carbonate has all reacted with the liberated ethanoic acid will the ethanoic acid concentration rise and the pH value fall. The reaction time is measured from the initial point of mixing the solutions until the end-point of the indicator is reached.

**Questions on background information**

- 1 How can you tell from its formula that oleic acid is likely to be mono-unsaturated?
- 2 Suggest an alternative structure for  $C_{17}H_{33}COOH$  in which the alkyl group is fully saturated.
- 3 A sample of glycerol triethanoate was completely hydrolysed by lipase. The ethanoic acid formed required  $17.5 \text{ cm}^3$  of aqueous sodium hydroxide of concentration  $0.100 \text{ mol dm}^{-3}$  for complete neutralisation. Calculate the number of moles, and hence the mass, of glycerol triethanoate in the sample.

**Safety**

Materials safety data sheets should be consulted so that the correct action can be taken in event of a spillage and/or accident.

	<b>You must wear eye protection throughout this experiment</b>
	Sodium carbonate is an <b>irritant</b>

**Procedure**

1. Add the triacetin solution, distilled water and sodium carbonate solution to the numbered test tubes as shown in the table below.

test tube	triacetin / $\text{cm}^3$	water / $\text{cm}^3$	sodium carbonate / $\text{cm}^3$	lipase / $\text{cm}^3$
1	1.00	4.30	0.50	0.20
2	1.00	4.25	0.50	0.25
3	1.00	4.20	0.50	0.30
4	1.00	4.10	0.50	0.40
5	1.00	4.00	0.50	0.50
6	1.00	3.90	0.50	0.60
7	1.00	3.80	0.50	0.70
8	1.00	3.50	0.50	1.00

2. Add 4 drops of bromocresol indicator to each test tube.
3. Add the lipase solution and start the clock. **Warning:** tubes 6, 7 and 8 are very quick!
4. Shake the tubes and continue to shake them every 30 seconds. This is necessary to ensure that the triacetin and lipase solution are continually mixed otherwise the triacetin will separate out.
5. Record the time when each solution turns yellow in the table below.
6. Calculate the value for  $1/t$  for each experiment; this represents the reaction rate of each experiment.
7. Multiply the reaction time, **t**, by the appropriate conversion factor shown in the table below.
8. Plot the reaction time, **t**, against the volume of lipase used in **Graph 1**.
9. Plot the reaction rate,  $1/t$ , against the volume of lipase used in **Graph 2**.

## Appendix 2

10. Plot the **weighted reaction time** against the volume of lipase used in **Graph 3**. Calculate the weighted reaction time by using the following relationship.

$$\text{weighted reaction time} = \text{actual reaction time} \times \text{conversion factor}$$

**Results**

test tube	reaction time 't' / s	1/t / s <sup>-1</sup>	conversion factor	weighted reaction time / s
1			0.20	
2			0.25	
3			0.30	
4			0.40	
5			0.50	
6			0.60	
7			0.70	
8			1.00	

**Questions on results**

- 1 What sort of curve is produced in **Graph 1**? Is it exponential?
- 2 How does the rate of reaction change with increasing enzyme concentration? (See **Graph 2**)
- 3 If the reaction time is proportional to the enzyme concentration then a plot of the weighted reaction time against the volume of lipase used should give a straight line. By considering **Graphs 2 & 3**, deduce the rate order with respect to the lipase concentration.

### 13. Experiments with enzymes – the effect of enzyme concentration on reaction rate

#### Teachers' Notes

This is a relatively straightforward rates exercise in which the effect on the rate of an enzyme catalysed reaction of varying the concentration of the enzyme is investigated. The volumes involved are quite small, so the use of syringes rather than pipettes or burettes is recommended if available.

In the exercise, glycerol triethanoate (triacetin) is used as the substrate. Lipase breaks this substrate down into glycerol and ethanoic acid as shown below.

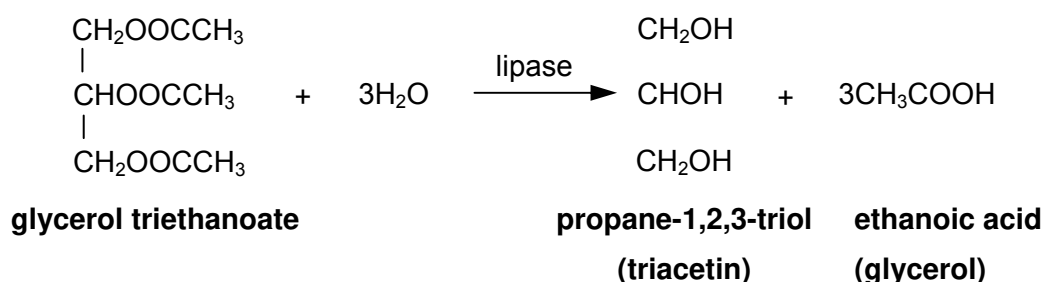

The ethanoic acid produced lowers the pH of the solution. The rate is determined by measuring the time needed to reduce the pH to a value determined by mid-point colour of a chosen indicator. In this case the indicator is **bromocresol purple**, which changes from purple at high pH values to yellow at lower pH values. Sodium carbonate is added to the triacetin to hold the pH high enough so that the colour remains purple. Only after the sodium carbonate has all reacted with the liberated ethanoic acid will the acid concentration rise and the pH value fall sufficiently low to trigger the colour change in the indicator. The reaction time is measured from the initial point of mixing the solutions until the end-point of the indicator is reached.

It might prove useful to revise the basic rates theory from the AS course prior to doing this exercise. Great emphasis should be placed on the importance of accurate volume measurements, as an error of a single drop in measuring the volume of the lipase solution will have significant consequences in terms of experimental accuracy. This point is best made by calculating the percentage error when, for example, 1 drop (around  $0.05 \text{ cm}^3$ ) too much/too little lipase solution is added in **Experiment 1** (where the required lipase volume is only  $0.20 \text{ cm}^3$ ).

The questions provide an opportunity to consolidate AS knowledge. Also, this exercise could be performed as a practice exercise before tackling the urease planning exercise.

#### Answers to questions on background information

- The formula  $\text{C}_{17}\text{H}_{33}$  is two hydrogen atoms short of the formula of an alkyl group ( $\text{C}_n\text{H}_{2n+1}$ ), and this corresponds to the presence of one  $\text{C}=\text{C}$  bond.
- The missing 2 hydrogen atoms could signify the presence of a cyclic **R** group.
- $\text{moles NaOH} = 17.5 \times 10^{-3} \times 0.100 = 1.75 \times 10^{-4} \text{ mol}$   
 $\text{moles CH}_3\text{COOH} = 1.75 \times 10^{-4} \text{ mol}$   
 $\text{moles glycerol triethanoate} = 1.75 \times 10^{-4} \div 3 = 5.83 \times 10^{-4} \text{ mol dm}^{-3}$   
 $M_r (\text{C}_6\text{H}_{14}\text{O}_6) = 182$   
 $\text{mass glycerol triethanoate} = 5.83 \times 10^{-4} \times 182 = 0.106 \text{ g}$



### Answers to questions on results

The answers provided by the students provide valuable information about their understanding of what analysis and evaluation involves. It is suggested that a set of results, which are flawed in some way, are analysed and evaluated by the whole class. The likelihood is that their understanding will be significantly broadened and misconceptions can be dealt with.

### Technical information

Requirements per student/group

#### Apparatus

- eight test tubes (labelled 1 to 8) and rack
- distilled/deionised water
- three 1 cm<sup>3</sup> syringes and one 5 cm<sup>3</sup> syringe, or equivalent pipettes/ graduated pipette
- stopclock

#### Materials

- Access to 5% lipase solution (this should be freshly prepared and filtered).
- Access to 0.5% sodium carbonate solution.
- Access to **Bromocresol purple** solution (as provided).
- Access to **Triacetin** (as provided).

#### Safety

The main points are included on the Student Sheet but it is the teacher's responsibility to ensure that a full risk assessment is carried out prior to the practical session. MSDS sheets should be consulted so that the correct action can be taken in event of a spillage and/or accident.

## 14. Experiments with enzymes – planning an enzyme concentration vs. rate experiment

### Student Sheet

In this experiment you will use your knowledge of previous rate experiments, and the information given below, to plan an investigation of the effect changing the concentration of an enzyme has on the rate of the reaction it catalyses. The reaction involved is the hydrolysis of urea, using urease as the enzyme.

#### Intended lesson outcomes

By the end of this exercise you should be able to:

- Produce a detailed plan of how the experiments will be performed
- Deduce the quantities of solutions to be used
- Identify the apparatus needed
- Decide on how the results will be analysed and evaluated
- Assess the risks involved and suggest appropriate safety precautions

#### Background information

**Urease** is an enzyme that breaks down urea,  $\text{CO}(\text{NH}_2)_2$ , into carbon dioxide and ammonia. The production of ammonia raises the pH of the solution and can be detected by using a suitable acid-base indicator.

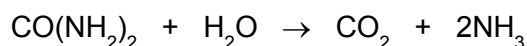

Urease is active over a wide range of pH so any number of indicators can be used provided that the original solution is buffered at the right level to start with. You have the choice of two indicators, **bromothymol blue** and **phenolphthalein**. Don't forget that enzymes are temperature sensitive.

Bromothymol blue ( $pK_{\text{in}} = 7.0$ ) has a colour change, from yellow in acid to blue in alkali, which occurs around pH 6 to 8. The mid-point colour, turquoise, occurs at about pH 7.5 and the colour transition from yellow, through turquoise to blue is quite sharp. A control tube containing pH 7.5 buffer and indicator may be used to help identify the end-point.

Phenolphthalein ( $pK_{\text{in}} = 9.3$ ) has a colour change, from colourless in acid to red in alkali, which changes from colourless to pink at a higher pH than the change with bromothymol blue, and the change from colourless to pink occurs only very slowly. The colour becomes a more intense pink with time, so the end-point is the **first** faint pink coloration.

About 4 drops of either indicator would normally be used.

The method to be used in this investigate is based on a 'clock reaction' type of experiment for studying reaction rates – remember the 'iodine clock' experiment. The time taken for sufficient ammonia to be produced to overcome the buffer present is being measured. This is determined by measuring the time taken for sufficient ammonia to be produced to trigger the end-point of the indicator.

The pH of the buffer used **must not** be too close to the pH at the end-point of the indicator; otherwise the end-point will be reached too quickly.

#### Experimental details

In a similar experiment, a mixture containing  $3.00 \text{ cm}^3$  of urea solution,  $1.00 \text{ cm}^3$  of buffer solution,  $1.50 \text{ cm}^3$  of urease solution,  $0.50 \text{ cm}^3$  of water and 4 drops of indicator solution took 32 seconds to reach the end-point of the indicator.

## Plan

Your plan should include the following:

- A description of **how** you would mix and **measure** the reagents. You may assume you are supplied with aqueous solutions of urea, urease, buffer (pH 5 or pH 7 as you choose) and your chosen indicator. You also have a supply of distilled water and whatever equipment you wish.
- Details of how you would ensure that your experiments provide a *fair test*.
- A description of how you would measure the time taken for the reaction to reach your selected end-point.
- Details of the number and range of experiments you would perform to enable you to determine the effect of enzyme concentration on the rate of the reaction.
- A results table showing how your results would be recorded and how these data would be manipulated so that you could analyse your results graphically.
- An explanation of how you would use graphical methods to determine the effect of enzyme concentration on the reaction rate. You should not invent results but you may sketch one or more graphs to help you in your explanation.
- A brief statement of how you analyse your graphical results and what further experiments you may need to perform as a result of your analysis.
- A brief outline of any safety factors involved and the measures you would take to reduce or eliminate them.

## Safety

A full risk assessment with reference to materials safety data sheets should be carried out for your plan.

## 14. Experiments with enzymes – planning an enzyme concentration vs. rate experiment

### Teachers' Notes

Planning exercises work best when students have sufficient knowledge of the topic not to need the support of books or notes. As planning may be a new skill to many students it is recommended that at the beginning of the course, group work is used so students can pool ideas and learn from each other. As students become more confident, they can progress to individual work, and finally to practising planning exercises under exam conditions.

From the student's point of view, often the most difficult part of a planning exercise is getting started. Be prepared to give help early on in the learning process, but encourage students to be more independent as the course progresses.

#### The main questions you might wish to consider when assessing the plan are:

- is the method used clearly described?
- have appropriate techniques, reagents and pieces of apparatus been selected?
- is there an appreciation of scale and precision (including relevant calculations)?
- is the suggested analysis/evaluation of the data obtained complete and workable?
- have all the appropriate safety factors been properly considered?

The following list of points will help you work through the students' plans methodically and give appropriate feedback or marks.

#### Equipment

- Use of syringe/pipettes/burettes to measure volumes
- Suitable container of specified capacity
- If appropriate, a suitable device for holding the containers – e.g. a test tube rack
- Timer reading to a specified degree of precision

#### Procedure

1. Chooses bromothymol blue as indicator. Explains choice in terms of sharp end-point and rapid transit through colour change.
2. If using bromothymol blue, sets up a control test-tube by adding sensible volume, e.g. 5 cm<sup>3</sup>, of pH 7.5 buffer and adding 4 drops of the indicator.
3. If using phenolphthalein, reference to the first sign of pink colour.
4. Specifies an appropriate buffer solution; pH 5 for bromothymol blue or pH 7 for phenolphthalein
5. Specifies a suitable **number** and **range** of experiments to be done.
6. Keeps volume constant by adjusting the volume of water added.
7. Keeps all solution volumes, apart from the enzyme solution, constant.
8. Adds 4 drops of chosen indicator.
9. Sensible mixing procedure, adding the enzyme last.
10. Adds final reagent and starts timer.
11. Stops timer at defined/described end-point.
12. Records data in results table to a degree of precision appropriate to the apparatus used.
13. Repeats with different mixtures.

## Appendix 2

14. Suggests the use of an effective form of temperature control.

**Analysis**

1. Calculates  $1/\text{time}$  to represent rate. (May suggest logarithmic graphs to determine rate order.)
2. Sketches expected graphs of reaction time ( $t$ ) against volume of urease, and rate ( $1/t$ ) against volume of urease.

**Evaluation**

Suggests how the analysis might be evaluated in terms of:

1. Identifying anomalous results
2. Comparing the graphical results with known outcomes.
3. Deducing that the graph of rate vs. volume graph should show a straight line, starting from origin.

**Safety**

Identifies **two** appropriate risks and suggests appropriate targeted precautions.

**Technical information**

- Access to hazard cards or equivalent safety data
- When candidates have some experience in planning, this exercise could be carried out in exam-style conditions with a time limit of around 1 hour

**Extension work**

You may wish to perform this exercise as a class practical, either by using the students' own plans, or by using the method described below. Students should prepare their own results table and plot the appropriate graphs. They should then analyse and evaluate their results.

**The effect of enzyme concentration on reaction time**

The background information for this exercise is as for the planning exercise.

**Procedure**

1. Decide which indicator you are going to use (either phenolphthalein or bromothymol blue).
2. If using bromothymol blue, set up a control test-tube by adding  $5 \text{ cm}^3$  of pH 7.5 buffer and adding 4 drops of the indicator. This shows the turquoise mid-point colour change that can be used to determine a 'standard' end point for the reaction.
3. Label 8 test tubes 1 to 8.
4. Add the required buffer solution (pH 5 for bromothymol blue and pH 7 for phenolphthalein), water and urea solution to each of the tubes as shown in **the table below**.
5. Add 4 drops of the indicator to each tube.
6. Add the required amount of urease (from **the table below**) and start timing.  
**WARNING:** Tubes 7 and 8 can be very quick!
7. Shake the tubes to ensure the contents are mixed thoroughly. It may be necessary to shake the tubes during the experiment to ensure the colour is the same throughout the solution
8. Record the time when each tube shows the correct end-point colour. This is either turquoise for bromothymol blue or the faintest hint of pink if using phenolphthalein.

## Appendix 2

9. Plot the reaction time against the volume of urease used.
10. The rate of reaction is fastest in the mixture that gives the shortest reaction time; so the rate of the reaction can be approximated to  $1/\text{reaction time}$ . Plot a graph of rate of reaction against the volume of urease used.

Test tube	Urea / cm <sup>3</sup>	Water / cm <sup>3</sup>	buffer* / cm <sup>3</sup>	Urease / cm <sup>3</sup>
1	3.00	1.90	1.00	0.10
2	3.00	1.80	1.00	0.20
3	3.00	1.70	1.00	0.30
4	3.00	1.60	1.00	0.40
5	3.00	1.40	1.00	0.60
6	3.00	1.20	1.00	0.80
7	3.00	1.00	1.00	1.00
8	3.00	0.50	1.00	1.50

- Use pH 5 buffer if using bromothymol blue.
- Use pH 7 buffer if using phenolphthalein.

### Technical information

Requirements per student/group

### Apparatus

- nine test tubes (eight of them labelled 1 to 8) and rack
- access to distilled water
- three 1 cm<sup>3</sup> syringes and one 5 cm<sup>3</sup> syringe, or equivalent pipettes / graduated pipette
- stopclock/timer

### Materials

- access to bromothymol blue solution
- access to phenolphthalein solution
- access to 3% **urease** solution: add 3.0 g of urease active meal to 100 cm<sup>3</sup> of distilled water. Stir/shake the solution for at least 5 minutes to extract the urease. Filter off the undissolved material (this can be quite slow). This solution should be freshly prepared.
- access to 2% **urea** solution: dissolve 20 g urea in 1 dm<sup>3</sup> of distilled/deionised water.
- access to pH 5 **buffer** solution: add 2.4 g of buffer powder pH 5 to 200 cm<sup>3</sup> of distilled water and stir until dissolved.
- access to pH 7 **buffer** solution: add 4.8 g of buffer powder pH 7 to 200 cm<sup>3</sup> of distilled water and stir until dissolved.
- access to pH 7.5 **buffer** solution: add 0.80 g of buffer powder pH 7.5 to 100 cm<sup>3</sup> of distilled water and stir until dissolved.

### Safety

MSDS sheets should be consulted for any materials used.

## 15. Determination of the order of the reaction between hydrogen peroxide and iodide ions in the presence of sulphuric acid

### Student Sheet

#### Intended lesson outcomes

By the end of this exercise you should be able to:

- measure liquid volumes using a burette
- use a stopclock
- adapt an experiment to measure the effect of a different variable
- analyse data graphically
- deduce rate orders, write a rate equation and calculate a value for the rate constant

#### Background information

The rate of formation of iodine in the reaction:

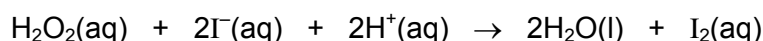

is given by:

$$\text{rate} = k[\text{H}_2\text{O}_2]^a[\text{I}^-]^b[\text{H}^+]^c$$

where  $k$  is a constant at a given temperature and **a**, **b**, **c** represent the order of reaction with respect to the three reactants.

In the presence of sodium thiosulphate, the iodine liberated in the above reaction reacts with the sodium thiosulphate until no more sodium thiosulphate remains. As excess iodine forms, the solution becomes coloured. By adding a few drops of starch, the iodine is shown up more clearly as it forms a blue complex.



The initial rate for the above reaction is determined by allowing the reaction to proceed in the presence of a known, small amount of sodium thiosulphate. The time interval that elapses before this is used up, i.e. before excess iodine appears is measured. The reciprocal of this time ( $1/t$ ) is used as a measure of the initial rate of reaction.

**Note:** This method of determining the initial rate assumes that the actual rate does not vary over this period of time. This is not strictly true, but the error in the initial rate measurement is unlikely to be significant.

The rate order with respect to individual components may be deduced from a graph of the initial reaction rate vs. the concentration of the component under investigation. If the rate order with respect to that component is zero, then the rate of reaction will be independent of the concentration of that component and a graph of rate vs. concentration will be a horizontal straight line. If the rate order is one, the rate vs. concentration graph will be straight, sloping and will pass through the origin. For rate orders higher than one, the rate vs. concentration graph, while still passing through the origin, would be curved, and a more complex graph would have to be drawn to determine the actual rate order.

**Safety**

MSDS sheets should be consulted so that the correct action can be taken in event of a spillage and/or accident.

	<b>You must wear eye protection throughout this experiment</b>
	Hydrogen peroxide and sulphuric acid are <b>corrosive</b> .

**Procedure****Experiment 1**

- Using burettes, measure out 10.0 cm<sup>3</sup> aqueous potassium iodide and 10.0 cm<sup>3</sup> of dilute sulphuric acid into a small conical flask; then add to this mixture 3-4 drops of starch.
- Using burettes, measure out 3.0 cm<sup>3</sup> of aqueous sodium thiosulphate and 1.0 cm<sup>3</sup> of hydrogen peroxide into a test tube.
- Add the contents of the test tube to the conical flask, start the stopclock immediately while swirling the contents of the flask.
- Measure the time that elapses before a blue colour appears.
- Record your result in the table.
- Repeat the experiment, but using 8.0 cm<sup>3</sup>, 6.0 cm<sup>3</sup>, 4.0 cm<sup>3</sup> and 2.0 cm<sup>3</sup> of potassium iodide, and adding deionised water to keep the total volume constant throughout.
- Complete the table by calculating the values for 1/t.

tube	volume of H <sub>2</sub> O <sub>2</sub> / cm <sup>3</sup>	volume of H <sub>2</sub> SO <sub>4</sub> / cm <sup>3</sup>	volume of KI / cm <sup>3</sup>	volume of Na <sub>2</sub> S <sub>2</sub> O <sub>3</sub> / cm <sup>3</sup>	volume of water / cm <sup>3</sup>	time t / s	'rate' 1/t / s <sup>-1</sup>
1	1.0	10.0	10.0	3.0	4.0		
2	1.0	10.0	8.0	3.0	6.0		
3	1.0	10.0	6.0	3.0	8.0		
4	1.0	10.0	4.0	3.0	10.0		
5	1.0	10.0	2.0	3.0	12.0		

**Experiment 2**

Repeat Experiment 1, but this time vary the volume of sulphuric acid by using 8.0 cm<sup>3</sup>, 6.0 cm<sup>3</sup>, 4.0 cm<sup>3</sup> and 2.0 cm<sup>3</sup> of acid, but keep the total volume constant by adding deionised/distilled water. Construct a suitable table for this experiment and use it to record your results. Complete your table by calculating the values for 1/t.

**Note:** Your **first** result from experiment 1 also forms part of this experiment.

**Experiment 3**

Repeat Experiment 1, but this time vary the volume of hydrogen peroxide by using 2.0 cm<sup>3</sup>, 3.0 cm<sup>3</sup>, 4.0 cm<sup>3</sup> and 5.0 cm<sup>3</sup> of the peroxide solution. As in experiment 1, keep the total volume constant by adding deionised/distilled water. Construct a suitable table for this experiment and use it to record your results. Complete your table by calculating the values for 1/t.

**Note:** Your **first** result from experiment 1 also forms part of this experiment.



### Interpretation

You are now going to interpret your results graphically. You will use your values for the reciprocal of time,  $1/t$ , as a measure of the rate of reaction, and the volume of the independent variable as a measure of its concentration.

- 1 Plot separate graphs of rate vs. concentration ( $1/t$  vs. volume used) for each of the above experiments.
- 2 By considering the shape of each graph, deduce the rate order with respect to each component and hence find values for **a**, **b** and **c** in the rate expression.
- 3 Explain why it is acceptable to use volume rather than concentration data in your graphs.
- 4 Use your data from tube 1, Experiment 1, and your rate expression from point 2, to deduce the value of the rate constant,  $k$ .
- 5 Identify any limitations of your experiment and suggest ways of overcoming them.

## 15. Determination of the order of the reaction between hydrogen peroxide and iodide ions in the presence of sulphuric acid

### Teachers' Notes

Students should be instructed to prepare each mixture only when it is required. Once a reaction is complete, the conical flasks must be washed thoroughly, otherwise contamination left behind in a flask may cause a subsequent experiment to start prematurely.

If preferred, the hydrogen peroxide could be measured out into a test tube and added quickly, with the clock being started simultaneously, rather than using a burette. Doing it this way will ensure easier access to the communal supply of hydrogen peroxide, as the time of collection will not be so critical.

The iodine produced by the reaction below, reacts immediately with the thiosulphate ions,  $\text{S}_2\text{O}_3^{2-}$ , present in each mixture.

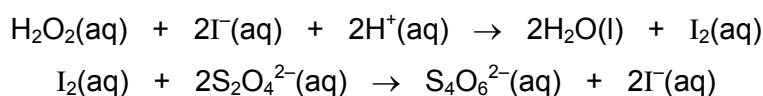

Only when all the thiosulphate ions are removed, will an excess of iodine accumulate, resulting in the deep blue colour of the starch/iodine complex being formed. The blue colour develops rapidly; this is the endpoint of the reaction.

It is vital that the same amount of sodium thiosulphate is present each time. Great emphasis should be placed on accurate burette use, especially with regard to measuring the sodium thiosulphate solution.

### Interpretation answers

3 The initial concentration,  $c$ , of a given component in a reaction mixture is given by

$$c = \frac{\text{volume of solution of that component (vol)}}{\text{total solution volume}} = \frac{\text{vol}}{28}$$

i.e.  $c \propto \text{vol}$

4 The value of the rate constant,  $k$ , could be used as a measure of experimental accuracy. Rather than comparing the results obtained by the students with a book value (which will be temperature dependent anyway), it would be better to use the value obtained from the teacher's trial. This would have the advantage of compensating for any inaccuracies there might be in solution concentrations.

5 Suggested potential sources of error, and their remedies, should be sensible, specific and supported by sound argument.

This exercise is appropriately called the '*iodine clock experiment*'. With care, it is possible to achieve remarkably consistent and accurate results. At the conclusion of the exercise, you may wish to randomly choose a time, in seconds, and challenge your students to deduce the recipe for a solution, which would turn blue at this specified time. This will help develop their planning skills under time pressure. The ensuing race, in which each student/group mixes their reagent on your command, can be quite entertaining. It is likely that the winner will be within a second or two of your selected time.

### Materials (per student)

- Thermometer (range  $-10\text{ }^\circ\text{C}$  to  $+110\text{ }^\circ\text{C}$ )
- Communal burettes for chemicals (1) to (5)
- New test tubes for hydrogen peroxide
- Stopclock

## Appendix 2

- 150 cm<sup>3</sup> of 0.50 mol dm<sup>-3</sup> sulphuric acid
- 120 cm<sup>3</sup> of 0.10 mol dm<sup>-3</sup> potassium iodide
- 50 cm<sup>3</sup> of 0.010 mol dm<sup>-3</sup> sodium thiosulphate
- 30 cm<sup>3</sup> of 2.0 volume hydrogen peroxide
- Deionised/distilled water
- Fresh starch solution (0.5 g in 25 cm<sup>3</sup> H<sub>2</sub>O)

**Test solutions**

10.0 cm <sup>3</sup> potassium iodide	} 30–40 seconds
10.0 cm <sup>3</sup> sulphuric acid	
3.0 cm <sup>3</sup> sodium thiosulphate	
1.0 cm <sup>3</sup> hydrogen peroxide	

**Safety**

The main points are included on the Student Sheet but it is the teacher's responsibility to ensure that a full risk assessment is carried out prior to the practical session. MSDS sheets should be consulted so that the correct action can be taken in event of a spillage and/or accident.

## 19. The preparation and purification of methyl-3-nitrobenzoate

### Student Sheet

In this experiment you will learn or develop skills in preparative organic chemistry by making and purifying a sample of an aromatic nitro compound. You will assess the purity of your product by measuring its melting point and comparing it with the data book value.

#### Intended lesson outcomes

By the end of this exercise you should be able to:

- Determine the weight of a material using the **weighing by difference** method
- Handle hazardous materials safely
- Purify by recrystallisation
- Determine the yield and melting point of a reaction product
- Estimate the purity of a reaction product
- Write a mechanism for the electrophilic substitution reaction involved in nitration

#### Background information

Nitration of an aromatic ring occurs by an electrophilic substitution reaction. The electrophile is the nitronium ion,  $\text{NO}_2^+$ , which is prepared by the reaction between concentrated nitric acid and concentrated sulphuric acid. The equation for this reaction is given below.



The reaction conditions necessary for the nitration step which follows depend on the nature of the molecule being nitrated; as does the position into which the nitro group will be substituted. Using methylbenzoate, the reaction occurs readily, so that a relatively low temperature is sufficient, and the nitro group tends to be substituted into the 3-position on the benzene ring. Great care must be taken that appropriate cooling is used, and that the hazardous materials used are safely handled. Purification of the crude product is by recrystallisation from the minimum amount of hot ethanol.

The overall equation for the nitration reaction is

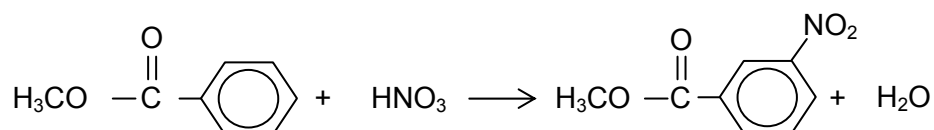





Once the nitro group has been introduced into the ring, it may be readily reduced to an amine group, by heating it with tin and concentrated hydrochloric acid. This reaction sequence provides a very useful route to the synthesis of aryl amines.

#### Question

Write a mechanism for the electrophilic substitution reaction involved in this reaction, showing clearly the structure of the intermediate species formed.

#### Safety

There are potentially hazardous substances involved in this exercise. You **must** follow all health and safety instructions given to you by your teacher. Materials safety data sheets should be consulted so that the correct action can be taken in event of a spillage and/or accident.

	<b>You must wear eye protection throughout this experiment</b>
	Methylbenzoate is <b>harmful</b>
	Nitric acid and sulphuric acid are <b>corrosive</b>
	Ethanol is <b>highly flammable</b>

### Procedure

1. Measure 9.0 cm<sup>3</sup> of concentrated sulphuric acid into a dry 100 cm<sup>3</sup> conical flask and place the flask in an ice bath.
2. Add about 4.0 cm<sup>3</sup> of methylbenzoate to a small measuring cylinder. Weigh the measuring cylinder and methylbenzoate recording the mass.
3. Prepare a **nitrating mixture** by carefully mixing 3.0 cm<sup>3</sup> of concentrated nitric acid and 3.0 cm<sup>3</sup> concentrated sulphuric acid in a test tube. Place this test tube in the ice bath.
4. Add the methylbenzoate to the conical flask; swirling the flask while you do so. Weigh the emptied measuring cylinder and calculate the mass of methylbenzoate added. This process is known as **weighing by difference**.
5. Using a dropping pipette, add the nitrating mixture to the conical flask. You must swirl the flask after each addition and, by monitoring the thermometer, adjust the rate of addition to ensure that the temperature **does not exceed 15 °C**. Do not rush the addition; it should take about 10–15 minutes.
6. After the addition is finished, allow the flask to stand at room temperature for about 10 minutes. Pour the reaction mixture from the flask into a small beaker containing about 40–50 g of crushed ice. Stir until the product solidifies.
7. Filter off the impure solid product, preferably using vacuum filtration, and wash the product, first with cold water and then with about 5 cm<sup>3</sup> of ice-cold ethanol. Allow the solid to dry as much as possible.

### Recrystallisation

8. Place the impure product in a clean 100 cm<sup>3</sup> conical flask and add 10 cm<sup>3</sup> ethanol. **Gently** warm the mixture in a water bath. If some of the solid fails to dissolve add further 2 cm<sup>3</sup> portions of ethanol until it does dissolve, **but** do not continue adding ethanol if it is clear that some material is not going to dissolve; your aim is to produce as concentrated a solution as possible.
9. If necessary, filter the solution using a filter funnel or Buchner funnel to remove any insoluble material. To prevent crystals forming during filtration, pre-heat the funnel by adding hot solvent to the filter paper in the funnel; allow time for the solvent to run through. Discard this hot solvent before you use the hot funnel to filter your solution.
10. Cool the filtrate in an ice bath until crystals form.
11. Filter off the crystals, preferably by vacuum filtration, and allow them to dry as much as possible. Transfer the crystals to a clean piece of filter paper on a watch glass. Let the crystals stand overnight to dry out completely.

## Appendix 2

12. Weigh the crystals by adding them to a pre-weighed sample bottle and reweighing.
13. Using the melting point apparatus provided, determine the melting temperature of your crystals.
14. Transfer your crystals to a sample bottle labelled with your name.

**Theoretical maximum mass of product**

15. From the mass of methylbenzoate added, deduce the **maximum** mass of methyl-3-nitrobenzoate which could be produced (i.e. if **all** the methylbenzoate had been converted into product).

**Percentage yield of product**

16. Calculate the percentage yield of your preparation. You do this by comparing your actual yield of product with the theoretical maximum yield and expressing the result as a percentage.

**Purity**

17. The pure product would have a melting point of  $77\text{ }^{\circ}\text{C} \pm 1\text{ }^{\circ}\text{C}$ ; compare your melting point to this value. The further away, and the wider the melting range, your melting point is compared to  $77\text{ }^{\circ}\text{C}$  the less pure is your product. Also, your crystals should be dry and pale yellow in colour. Comment on the appearance, yield and purity of your product and then show your product to your teacher, who will also assess its appearance and yield.

## 19. The preparation and purification of methyl-3-nitrobenzoate

### Teachers' Notes

Overall, the exercise provides a range of learning experiences for the student, which include: weighing and measuring, the safe handling of materials, temperature control, recrystallisation techniques and melting point determination.

#### Intended learning outcomes

Please see the Student Sheet

#### A suggested approach

The exercise provides considerable opportunity for students to practice and develop their manipulative skill. It may also help them to appreciate that organic reactions, unlike many inorganic reactions, require care and patience if they are to be successful, and that, despite all their care, yields are likely to be limited.

It would be worth spending a little time discussing the usefulness of this reaction in the synthesis of aryl amine and their products.

This exercise involves the use of potentially hazardous materials and so students should be closely supervised, unless they have considerable experience of organic preparations. The nitration reaction proceeds readily and so, in order to prevent multiple substitution, it is necessary to cool the reaction mixture. The use of vacuum filtration, using a Buchner filtration system, is preferred. The exercise may be successfully completed using gravity filtration, however, but it does take longer; especially in the final drying stage.

#### Note

The product from this reaction could be reduced to make the aryl amine. This is not advised, however, as the purity of the nitrated product cannot be guaranteed. If your students were to perform such a reduction reaction, it would be better to use a commercial sample of an appropriate aromatic nitro compound. The reaction process involves the use of concentrated hydrochloric acid, concentrated sodium hydroxide, ether extraction and steam distillation. The final purification of the phenylamine product is by distillation. This reaction sequence requires considerable practical experience but could, if wished, be performed as a demonstration. Details may be found in:

*Advanced Practical Chemistry*  
by JS Clarke & S Clynes (English University Press)

#### Technical information

Requirements per student/group

#### Apparatus

- Two 100 cm<sup>3</sup> conical flasks
- Large beaker/small trough/small washing up bowl for ice bath
- 100 cm<sup>3</sup> beaker for crushed ice
- Beaker for water bath
- Two/three 10 cm<sup>3</sup> measuring cylinders
- Thermometer for monitoring temperature during nitration
- Stirrer – unless the thermometer may be used for this purpose
- Buchner funnel and flask **or** filter funnel
- Filter paper for funnel and for drying crystals

## Appendix 2

- Suction pump (if Buchner system used)
- Two dropping pipettes
- The apparatus normally used for melting point determinations
- Marker pen for labelling test tubes
- Access to balance

**Materials**

- Access to methylbenzoate
- Access to concentrated nitric acid
- Access to concentrated sulphuric acid
- A supply of ethanol
- A supply of crushed ice
- Distilled/deionised water
- A supply of hot water for the recrystallisation

**Safety**

The main points are included on the Student Sheet. However:

It is essential that a risk assessment is carried out before a decision is taken to go ahead with this exercise. MSDS sheets should be consulted so that the correct action can be taken in event of a spillage and/or accident.

- It must be **made clear** to students that potentially hazardous materials are in use and that precautions are needed to minimise the risk to themselves and to others.
- Your **MUST** be prepared to **intervene** if a student seems to be unsure of a procedure, or is performing an unsafe operation.

A number of ways in which the exercise may be made less hazardous and more likely to succeed include:

- (i) Measuring out the concentrated acids yourself and supplying them to the students in a labelled conical flask labelled A and a labelled test tube.
- (ii) Using hot water from a kettle for the water bath during the recrystallisation stage.
- (iii) Supplying small pieces of crushed ice for the ice baths.
- (iv) Telling the students that their safe working practices are being **assessed**; whether this is true or not!



## 21. Planning an experiment to identify a carbonyl compound

### Student Sheet

In this exercise you will use your knowledge of the chemistry of carbonyl compounds, most of which is covered in the AS syllabus, to plan a series of experiments to identify a carbonyl compound from a small number of possibilities. You will also need to use spectroscopic data to confirm your identification.

#### Intended lesson outcomes

By the end of this planning exercise you will be able to:

- identify the relevant structural features of carbonyl compounds
- select suitable tests to use to identify an unknown carbonyl compound
- give outline details of each test, including possible observations
- outline the preparation and purification of a solid derivative
- discuss the use of spectroscopic data in confirming identity
- assess the risks involved and suggest appropriate safety precautions

#### The exercise

In this exercise you will be assessed on your ability to plan experiments to identify a carbonyl compound and to use spectroscopic data to confirm your identification.

#### Background Information

The carbonyl compound you have to identify is one of the following.

- propanal
- propanone
- butanal
- butanone
- pentan-2-one
- pentan-3-one

In your plan you must first identify the structural features of these compounds by which you will be able to distinguish between them. You should then propose an appropriate series of tests and spectral analyses to perform.

- Your plan does not need to include quantities but should give reagents and conditions.
- The carbonyl compounds are all colourless, flammable liquids.
- Your plan for the laboratory exercises should allow for the compound being any one of those listed. However, when describing the use of spectroscopic data, you may use one of the compounds as an example.
- You may use the NMR data tables provided to find chemical shift values.

#### Plan

Your plan should follow the sequence outlined below.

- 1 Identify the structural features of the carbonyl compounds that you will make use of in your tests and spectral analyses.

#### Chemical testing

- 2 Give an outline, including any possible observations, of a test you would perform to confirm that the unknown is a carbonyl compound.

## Appendix 2

- 3 Give an outline, including any possible observations, of a test you would perform to distinguish between an aldehyde and a ketone.
- 4 Give an outline, including any possible observations, of a test you would perform to identify all the compounds with a  $\beta$ -keto group ( $\text{CH}_3\text{CO}-$ ).
- 5 Describe how you would confirm the identity of the compound by preparing a solid derivative. You should include full practical details of how the derivative would be purified and how it would be used to confirm the identity of the carbonyl compound.

**Spectral analysis**

- 6 In this part of the plan you may use any one of the compounds listed. **Using one** of the possible compounds, describe how you would make use of spectroscopic data on the carbonyl compound to confirm your identification. The techniques you should consider are:
  - (i) Low-resolution nuclear magnetic resonance spectroscopy
  - (ii) Mass spectroscopy (including fragmentation patterns)

**Safety considerations**

- 7 Perform a risk assessment of your plan.

## 21. Planning an experiment to identify a carbonyl compound

### Teachers' Notes

Planning exercises work best when students have sufficient knowledge of the topic not to need the support of books or notes. As planning may be a new skill to many students it is recommended that at the beginning of the course, group work is used so students can pool ideas and learn from each other. As students become more confident, they can progress to individual work, and finally to practising planning exercises under exam conditions.

From the student's point of view, often the most difficult part of a planning exercise is getting started. Be prepared to give help early on in the learning process, but encourage students to be more independent as the course progresses.

In this exercise, students will need access to NMR spectroscopic data. These data should be no more than a simple table showing the chemical shift/ $\delta$  value ranges for common proton environments.

#### The main questions you might wish to consider when assessing the plan are

- Is the proposed overall method clearly described?
- Is the proposed overall method appropriate, logical and complete?
- Are the practical details provided adequate and workable?
- Is the scope of the plan comprehensive enough?
- Have all the appropriate safety factors been properly considered?

The following list of points will help you work through the students' plans methodically and give appropriate feedback or marks.

#### Structural Features

- Propanal and butanal have  $-\text{CHO}$  group and so are **aldehydes**
- Propanone, butanone, pentan-2-one and pentan-3-one have  $-\text{CCOC}-$  group and so are **ketones**.
- Propanone, butanone and pentan-2-one have a  **$\beta$ -keto group** ( $\text{CH}_3\text{CO}-$ ) group and so give positive results with the **tri-iodomethane (iodoform)** test.

#### Carbonyl test

- Add compound to 2,4-dinitrophenylhydrazine solution
- Yellow/orange precipitate with all five compounds

#### Aldehyde/ketone test

- Add compound to ammoniacal silver nitrate and warm or to Fehling's solution and heat
- If silver mirror/red precipitate formed then compound is an aldehyde
- If no silver mirror/red precipitate formed then compound is not an aldehyde so, as it is a carbonyl compound, it is a ketone.

#### Tri-iodomethane (iodoform) test

- To compound add  $\text{KI}(\text{aq})$  and  $\text{NaClO}(\text{aq})$  and warm the mixture.
- Cool the mixture; fine yellow crystals form with  $\beta$ -keto compounds.
- If no yellow precipitate, then compound does not contain a  $\beta$ -keto group.

#### Derivative

- Prepares 2,4-dinitrophenylhydrazine derivative (a 2,4-dinitrophenylhydrazone)

## Appendix 2

- Suggests a suitable quantity to prepare (students could be told to give details of quantities, or a reference to making 'sufficient for a melting point determination' might be acceptable).

**Recrystallisation**

- Filter off 2,4-DNP derivative and dissolve in **minimum volume** ...
- ... of **hot solvent**
- Details of how to filter solution **hot** (e.g. fluted filter paper/pre-heated funnel/use Buchner funnel)
- Cool solution and crystals form
- Filter crystals using Buchner funnel and flask, wash crystals with cold solvent and dry

**Melting point**

- Find melting temperature of crystals – brief details of technique to be used
- Compare melting temperature with those listed in data book or similar

**Spectroscopic analysis of chosen example**

- Quotes formula and correct  $m/e$  value for the molecular ion
- Quotes the formula and  $m/e$  value for one correct fragment ion from given compound
- Deduces number of peaks in nmr spectrum
- Deduces expected height/area under peaks/integration trace ratio in NMR spectrum

**Safety**

- Avoid use of naked flame/use of water bath because liquids flammable
- Wear eye protection at all times

**Technical information**

- Access to hazard cards or equivalent
- Access to the chemical shift/ $\delta$  value ranges for common proton environments
- No access to outside sources
- When candidates have some experience in planning, this exercise could be carried out in exam-style conditions with a time limit of around 1 hour

**Note:** Make a record of any help given to a student, and the extent of that assistance. However, students will need to be given access to appropriate hazard cards and spectroscopic data tables.

**Safety**

If this exercise is extended so that the students carry out their plans, you must check their risk assessments against the appropriate MSDS sheets and ensure that they are fully aware of any hazards.

## 24. Making an azo dye

### Student Sheet

In this exercise, you will prepare a synthetic dyestuff known as an azo dye.

#### Intended lesson outcomes

By the end of this exercise you should be able to:

- perform a reaction under low temperature conditions
- appreciate the need to work with care and precision
- recall the chemistry of diazotisation and coupling

#### Background information

When an aromatic amine (an aryl amine) is treated with nitrous acid, a reaction occurs in which a *diazonium salt* is formed. If the temperature is too high, above 5 °C, then this compound reacts with water and is lost. For this reason, this experiment is performed using a cooling ice/water mixture. The equation below shows the reaction between phenylamine and nitrous acid to form benzene diazonium chloride; this process is known as **diazotisation**.

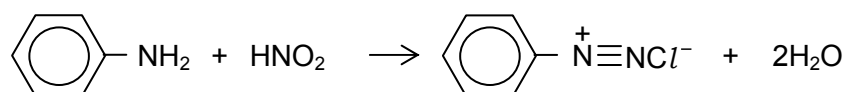

Diazonium salts act as electrophiles in some of their reactions. Thus, they are able to react with aromatic rings, for example benzene, using an electrophilic substitution mechanism. This reaction is known as a **coupling reaction** and the product is known as an **azo dye**, which is a stable molecule. The equation below shows the coupling reaction between benzene diazonium chloride and hydroxybenzene (phenol).

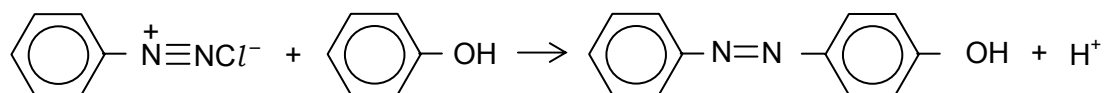

The azo dye formed in this reaction is orange in colour.

You are to prepare an azo dye using slightly more complicated reactants than those shown above. The aryl amine you will use is ethyl 4-aminobenzoate which, for simplicity, will be called substance **A**. This will be diazotised and the resulting diazonium salt will be coupled with naphthalen-2-ol ( $\beta$ -naphthol), which will be called substance **B**.

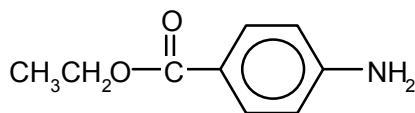

ethyl 4-aminobenzoate (substance **A**)

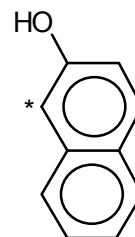







naphthalen-2-ol (substance **B**)

#### Questions

Draw the structures of the diazonium chloride formed from substance **A** and the azo dye produced when this diazonium chloride couples at position 1 with substance **B**; position 1 is marked on the above diagram with an asterisk (\*).

**Safety**

Materials safety data sheets should be consulted so that the correct action can be taken in event of a spillage and/or accident.

	<b>You must wear eye protection throughout this experiment</b>
	<b>Naphthalen-2-ol (2-naphthol) is harmful</b>
	<b>Sodium nitrite is oxidising</b>
	<b>and toxic</b>
	<b>Hydrochloric acid and sodium hydroxide are corrosive</b>
	<b>Naphthalen-2-ol and sodium nitrite are harmful to the environment. Your teacher will tell you how to dispose of them safely.</b>

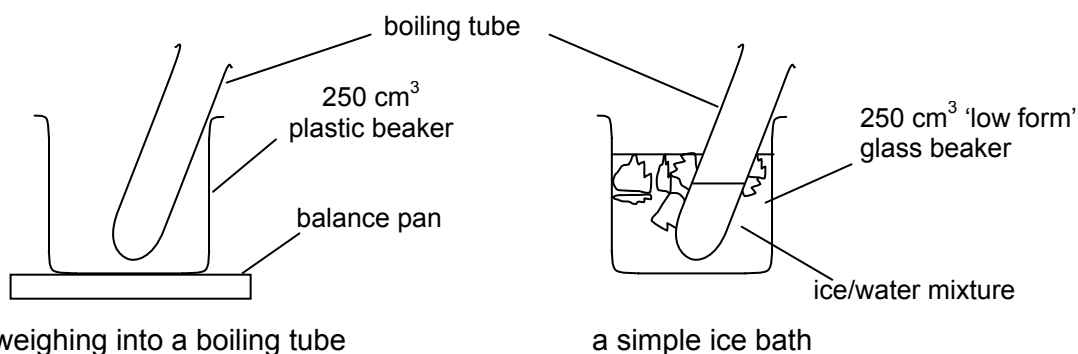
**Procedure**

- 1 Weigh 0.25 g of substance **A** into a boiling tube
- 2 Using a measuring cylinder add 10 cm<sup>3</sup> of dilute hydrochloric acid to the tube
- 3 Stir to dissolve the solid and place the tube in the ice/water bath (see above) to cool.
- 4 Into a second boiling tube weigh (see above) 0.25 g of sodium nitrite (**Toxic**).
- 5 Using a second measuring cylinder add 5 cm<sup>3</sup> of water to the second tube.
- 6 Stir to dissolve and place the tube in the ice bath to cool.
- 7 Place a 100 cm<sup>3</sup> glass beaker on the balance and weigh into it 0.50 g of substance **B**.
- 8 Using a measuring cylinder add 5 cm<sup>3</sup> of dilute sodium hydroxide solution (**Corrosive**) to the beaker, and place the beaker in the cooling mixture. Stir to dissolve the solid.
- 9 Add the cold solution of sodium nitrite slowly, using a teat pipette, to the acidified solution containing substance **A** prepared above (point 3). While you are doing this, leave both solutions in the cooling mixture to make sure that the temperature does not rise above 5 °C. The product of this reaction is the diazonium chloride.
- 10 Using a teat pipette, add drop-by-drop, and with stirring, the cold solution containing the diazonium chloride to the solution of substance **B**. Again, keeping both solutions in the cooling mixture. The azo dye is formed as a coloured precipitate.

## Appendix 2

- 11 Pour the mixture into a 250 cm<sup>3</sup> beaker containing cold water.
- 12 Filter the precipitate and wash it with cold water.
- 13 Transfer the precipitate to a watch glass to dry.

**Note: Be careful, dyestuffs are meant to colour things – especially clothes and unwary hands!**

## 24. Making an azo dye

### Teachers' Notes

This exercise shows how an azo dye may be prepared. The techniques used are relatively straightforward, but great care must be exercised with regard to temperature control and to the safe handling of materials.

#### Intended learning outcomes

Please see the Student Sheet

This exercise is likely to be used simply to provide an attractive practical experience and coverage of the chemistry of diazotisation and coupling. It could be extended, however, to extend and consolidate students' understanding. For example:

- The electrophilic substitution mechanism
- Students could be asked to suggest a mechanism for the reaction. More able students may well spot that the mechanism involves an electrophilic attack by the 'outer' nitrogen, with the associated donation of one of the bonding pairs from the triple bond onto the 'outer' nitrogen. The intermediate thus formed undergoing deprotonation in the normal way.
- The variation of colour in molecules with extended delocalised electron systems
- If a range of azo dyes is prepared, then the effect of changing the 'Chromophore' by attaching different arene rings to the azo bridge, or by using different substituents, 'Auxochromes', on these rings can be investigated. The indicator, 'Methyl orange' is an azo dye formed from the sodium salt of 4-aminobenzenesulphonic acid and *N,N*-dimethylphenylamine.
- The position of substitution in a substituted arene

The range of colour available from azo dyes is quite wide. The aryl amine to be diazotised, and the aryl hydroxy compound to which the product is to be coupled, can be varied to suit the availability of starting materials, and the colours required. The basic approach will be the same if different reagents are used but the quantities required will have to be calculated.

The exercise tends to be popular with students and should take around 30–45 minutes to complete. It could be extended to cover the purification of the dyestuff by recrystallisation, and the use of the dyestuff to colour fabric. To do this, the quantities used would need to be scaled up. Students would need to be warned, however, that those who are clumsy in their work are likely to be both colourful and easy to spot!

#### Answers to questions

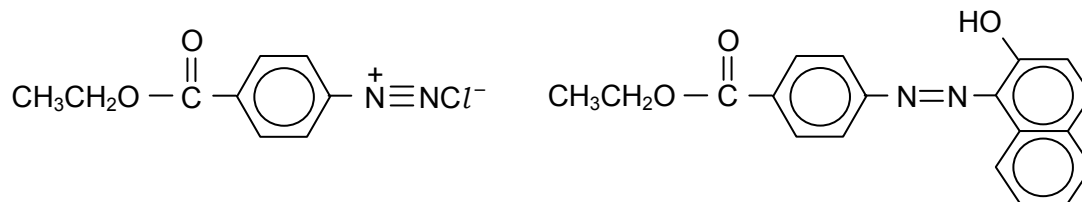

#### Technical Information

Requirements per student/group

- access to ethyl 4-aminobenzoate (substance **A**) – plus a spatula
- access to naphthalen-2-ol, (substance **B**) – plus a spatula
- access to solid sodium nitrite,  $\text{NaNO}_2$  – plus a spatula
- access to a balance (reading to at least 0.10 g)
- access to dilute hydrochloric acid (about  $1.0 \text{ mol dm}^{-3}$ )



## Appendix 2

- access to dilute sodium hydroxide (about  $1.0 \text{ mol dm}^{-3}$ )
- one  $250 \text{ cm}^3$  plastic beaker
- two  $10 \text{ cm}^3$  measuring cylinders
- two glass stirrers
- two boiling tubes
- $100 \text{ cm}^3$  glass beaker
- one ice bath ( $250 \text{ cm}^3$  or larger, low form glass beaker containing ice and water)
- two dropping pipettes
- two thermometers (range  $-10 \text{ }^\circ\text{C}$  to  $110 \text{ }^\circ\text{C}$ )
- filter funnel and filter paper or access to a vacuum filtration system
- watch glass

**Safety**

The main points are included on the Students' Sheet. However, it should be stressed that it is the responsibility of the teacher to ensure that a full risk analysis has been carried out; this is particularly important if alternative reagents are used. MSDS sheets should be consulted so that the correct action can be taken in event of a spillage and/or accident. Materials that are harmful to the environment should be disposed of according to local regulations.

## 25. Planning the preparation and purification of *N*-phenylethanamide

### Student Sheet

In this experiment you will use your knowledge of previous organic syntheses, and the information given below, to plan the preparation of a sample of *N*-phenylethanamide,  $C_6H_5NHCOCH_3$  starting from phenylammonium chloride,  $C_6H_5NH_3Cl$ , which is a salt of phenylamine.

#### Intended lesson outcomes

By the end of this exercise you should be able to:

- produce a detailed plan whereby a specified quantity of purified product may be prepared
- decide how the yield of product will be calculated
- decide how the purity of the product will be assessed
- assess the risks involved and suggest appropriate safety precautions

#### Background information

The preparation of *N*-phenylethanamide from phenylamine is termed **acylation**. Both ethanoyl chloride,  $CH_3COCl$ , and ethanoic anhydride,  $(CH_3CO)_2O$ , may be used as acylating agents. The reactivity of ethanoic anhydride is, however, lower than that of ethanoyl chloride and allows the reaction rate to be more easily controlled.

Phenylamine is most conveniently used in the form of the salt phenyl ammonium chloride.

The reaction is performed in two stages.

- 1 A solution of sodium ethanoate is treated with phenylammonium chloride forming phenylamine, ethanoic acid and sodium chloride.
- 2 Phenylamine then reacts with ethanoic anhydride to form *N*-phenylethanamide as a white solid, together with ethanoic acid.

An aqueous solution of phenylammonium chloride (5.0 g in  $150\text{ cm}^3$ ) is mixed with ethanoic anhydride ( $10\text{ cm}^3$ ). To this mixture is added a second aqueous solution containing sodium ethanoate (30 g in  $125\text{ cm}^3$ ). The sodium ethanoate causes the reaction in step 1 to occur. Once phenylamine is released, it reacts readily with ethanoic anhydride to form *N*-phenylethanamide as a white solid. The crude solid product is isolated and recrystallised from water. Typically a yield of around 70% of the theoretical maximum is obtained.

#### Note

An excess of ethanoic anhydride is used in order to ensure a good yield.

#### The task

Give **full details** of how a 2.0 g sample of **pure** crystalline *N*-phenylethanamide could be prepared using the above solutions, without preparing an excess of product. When calculating the quantities of materials to be used, you should assume a **maximum overall yield** for the preparation of **70%**.

Give details of a physical test you would perform to confirm the purity of the crystals.

#### Your plan should include:

1. A list of the essential apparatus you would use
2. Equations for the reactions taking place

## Appendix 2

3. The relative formula masses,  $M_r$  values, of phenyl ammonium chloride and *N*-phenylethanamide
4. The mass of phenylammonium chloride needed to make 2.0 g of *N*-phenylethanamide assuming a 100% yield
5. The quantities of phenylammonium chloride, ethanoic anhydride and sodium ethanoate needed to make 2.0 g of *N*-phenylethanamide assuming a 70% yield

**Note:** The workings for all calculations should be shown.

6. Full details of procedures by which 2.0 g of **pure, dry** *N*-phenylethanamide could be prepared
7. A physical test that you would do in order to assess the purity of your product
8. A full description of how you would perform the physical test for purity, and how you would interpret its results
9. Details of any potential risks in the procedure, and appropriate safety precautions to be taken

## 25. Planning the preparation and purification of *N*-phenylethanamide

### Teachers' Notes

Planning exercises work best when students have sufficient knowledge of the topic not to need the support of books or notes. As planning may be a new skill to many students it is recommended that at the beginning of the course, group work is used so students can pool ideas and learn from each other. As students become more confident, they can progress to individual work, and finally to practising planning exercises under exam conditions.

From the student's point of view, often the most difficult part of a planning exercise is getting started. Be prepared to give help early on in the learning process, but encourage students to be more independent as the course progresses.

**The main questions you might wish to consider when assessing the plan are:**

- 1 is the method used clearly described?
- 2 have appropriate techniques, reagents and pieces of apparatus been selected?
- 3 is there an appreciation of scale and precision (including relevant calculations)?
- 4 have all the appropriate safety factors been properly considered?

When deciding on a marking scheme for this plan, you could award one mark for each of the points below. However, this would place a greater emphasis on the *assessing the purity section* than on the *scale and precision* section. A second possibility is to mark each section to a maximum for that section. One way of doing this is illustrated below. The figure in brackets after each heading shows the maximum mark for that section, with a breakdown of how those marks are awarded, giving a maximum mark of 21 for the exercise. To change the emphasis of the plan, all that is needed is to change the mark allocation to each section.

### Marking the plan

There are five main areas to consider.

#### 1 Scale and precision: 1 mark for each (maximum mark = 6)

1. The correct equation for the reaction between phenyl ammonium chloride and sodium ethanoate.

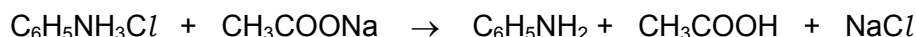

2. The correct equation for the reaction between phenylamine and ethanoic anhydride.

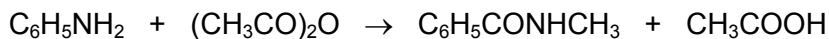

3.  $M_r$  values: for phenylammonium chloride = 129.5; for *N*-phenylethanamide = 135
4. Theoretical amount of phenyl ammonium chloride needed for 2.0 g yield = 1.92 g
5. Actual amount for phenyl ammonium chloride 2.0 g yield = 2.74 g
6. Sensible quantities of the other reagents

#### 2 Method, including apparatus: 6/7 correct = 4 marks; 4/5 correct = 3 marks; 3/4 correct = 2 marks; 1/2 correct = 1 mark (maximum mark = 4)

1. measuring cylinders
2. conical flask or other suitable vessel
3. access to a balance
4. filtering apparatus, e.g. Buchner apparatus

## Appendix 2

5. mixes solution and stirs
6. removes crude product by filtration
7. washes crude product with cold water

**3 Purification of the crude product:** 4 correct = 3 marks; 3 correct = 2 marks; 1/2 correct = 1 mark (maximum mark = 3)

1. dissolves in the minimum quantity of hot water
2. filters while hot
3. cools hot solution, filters crystals, dries crystals
4. weighs dry sample

**4 Assessing the purity of the recrystallised product:** 6 correct = 4 marks; 4/5 correct = 3 marks; 3/4 correct = 2 marks; 1/2 correct = 1 mark (maximum mark = 4)

1. appropriate method chosen e.g. melting point (possibly mixed melting point or the use of spectral analysis)

*outcome – e.g.*

2. product melts sharply
  3. melting point agrees with data book value
- basic technique used – e.g.*
4. sample placed in melting point tube
  5. states type of / describes melting point apparatus
  6. heats slowly near melting point

**5 Safety:** 6/7 correct = 4 marks; 5/4 correct = 3 marks; 3/4 correct = 2 marks; 1/2 correct = 1 mark (maximum mark = 4)

1. phenyl ammonium chloride and *N*-phenylethanamide are both **toxic**
2. ethanoic anhydride is **corrosive**
3. there are potential **fire hazard** with organics
4. avoid skin contact
5. wash areas affected by spillage with water
6. wear gloves
7. wear eye protection

**Technical information**

- Access to hazard cards or equivalent
- When candidates have some experience in planning this exercise could be carried out in exam-style conditions with a time limit of around 1 hour

## 26. The preparation and purification of *N*-phenylethanamide

### Student Sheet

In this experiment you will learn or develop skills in preparative organic chemistry by making and purifying a sample of an aromatic amide using an acylation reaction. You will assess the purity of your product by measuring its melting point and comparing it with the data book value. The acylating agent you will be using is ethanoic anhydride,  $(\text{CH}_3\text{CO})_2\text{O}$ . This is used in preference to ethanoyl chloride,  $\text{CH}_3\text{COCl}$ , as the latter is rather too reactive for use in these circumstances.

#### Intended lesson outcomes

By the end of this exercise you should be able to:

- determine the weight of a material using the **weighing by difference** method
- handle hazardous materials safely
- purify by recrystallisation
- determine yield and melting point
- estimate the purity of a product

#### Background information

The preparation of *N*-phenylethanamide from phenylamine is termed **acylation**. Both ethanoyl chloride,  $\text{CH}_3\text{COCl}$ , and ethanoic anhydride,  $(\text{CH}_3\text{CO})_2\text{O}$  may be used as **acylating agents**. The reactivity of ethanoic anhydride is, however, lower than that of ethanoyl chloride and so allows the reaction rate to be more easily controlled.

The equation for the acylation of phenylamine by ethanoic anhydride is given below.



Phenylamine is most conveniently used in the form of the salt phenyl ammonium chloride,  $\text{C}_6\text{H}_5\text{NH}_3\text{Cl}$ .

#### The reaction is performed in two stages

- 1 A solution of sodium ethanoate is treated with phenylammonium chloride forming phenylamine, ethanoic acid and sodium chloride.
- 2 Phenylamine then reacts with ethanoic anhydride to form *N*-phenylethanamide (as a white solid), together with ethanoic acid.

Aqueous solutions of phenylammonium chloride and ethanoic anhydride are mixed. To this mixture is added a second aqueous solution containing sodium ethanoate. The sodium ethanoate causes the reaction in stage 1 to occur. Once phenylamine is released, it reacts readily with ethanoic anhydride to form *N*-phenylethanamide as a white solid. The crude solid product is removed by filtration and purified by recrystallised from hot water. Typically a yield of around 70% of the theoretical maximum is obtained.





**Note:** An excess of ethanoic anhydride is used in order to ensure a good yield.

#### Questions

- Write an equation for the reaction occurring in stage 1.
- When phenylamine is treated with ethanoyl chloride, or with ethanoic anhydride, the product formed is *N*-phenylethanamide. Write equations for **both** of these reactions.

## Safety

There are potentially hazardous substances involved in this exercise. You **must** follow all health and safety instructions given to you by your teacher. Materials safety data sheets should be consulted so that the correct action can be taken in event of a spillage and/or accident.

	<b>You must wear eye protection throughout this experiment</b>
	Phenylammonium chloride is <b>toxic</b>
	and <b>dangerous for the environment</b> . Your teacher will tell you how to dispose of it safely.
	Ethanoic anhydride is <b>corrosive</b>

## Procedure

1. You are provided with 1.0 g of phenylammonium chloride. Dissolve this completely in 30 cm<sup>3</sup> of water in a conical flask.
2. To this solution, add 2.0 cm<sup>3</sup> of ethanoic anhydride.
3. Stir the mixture vigorously until all of the ethanoic anhydride has dissolved.
4. Weigh out 6.0 g of hydrated sodium ethanoate and dissolve it in 25 cm<sup>3</sup> of water in a conical flask.
5. Add the sodium ethanoate solution to the solution from (3) and stir the mixture for three minutes. If solid fails to appear, continue stirring for a further three minutes.
6. Filter off the crude product, using the filtration apparatus provided, and wash it with a little **cold** water. **Show** this crude product to your teacher before proceeding any further.

## Recrystallisation

7. Dissolve the whole of your product in the **minimum** volume of **hot** water in a boiling tube. Do this by adding hot water in small amounts until the solid dissolves. Stir the mixture with a glass rod to help the solid dissolve. When it has dissolved completely, allow the solution to cool.
8. **Note:** Your sample **may** contain some dark material that is insoluble. In this case, **do not** keep adding water. As soon as it is obvious that the bulk of the *N*-phenylethanamide has dissolved, filter the hot liquid carefully into a clean boiling tube.
9. Set your solution aside to cool.
10. When crystallisation is complete, filter off the pure product using the filtration apparatus provided. Dry the crystals between filter paper, then transfer them to a sample tube and leave them to dry in air. Label your sample tube.
11. Prepare a suitable table to record your yield and melting point.
12. Weigh your sample tube and contents. Transfer your sample into a second clean container and re-weigh the original, now empty, sample tube. This technique is known as **weighing by difference**. Enter your results in your table and calculate the mass of your product.

**Test for purity**

13. Determine the melting point of the substance, which should be above 100 °C. Record the melting point in your table. Show your purified sample to your teacher.

**Theoretical maximum mass of product**

14. Deduce, from the mass of phenylammonium chloride you used, the **maximum** mass of *N*-phenylethanamide which could be produced (i.e. if all the phenylamine had been converted into product).

**Percentage yield of product**

15. Deduce the percentage yield of your preparation. You do this by comparing the mass of your product with the theoretical maximum mass (from point 14) and expressing the result as a percentage.



## 26. The preparation and purification of *N*-phenylethanamide

### Teachers' Notes

The syllabus requires students to show an understanding of the chemistry of acyl chlorides. Given the hazards associated with this class of compound, the use of ethanoic anhydride provides a safer alternative to the use of ethanoyl chloride in ethanoylation reactions. Overall, the exercise provides a range of learning experiences for the student, which include: weighing and measuring, the safe handling of materials, recrystallisation techniques and melting point determination.

### Intended learning outcomes

Please see the Student Sheet

### A suggested approach

The exercise provides considerable opportunity for students to practice and develop their manipulative skill. It may also help them to appreciate that organic reactions, unlike many inorganic reactions, require care and patience if pure products are to be produced and that, despite all their care, yields are likely to be limited.

This exercise involves the use of potentially hazardous materials and so students should be closely supervised, unless they have considerable experience of organic preparations.

The use of vacuum filtration, using a Buchner filtration system, is preferred. The exercise may be successfully complete using gravity filtration, but it does take longer; especially in the final drying stage.

A brief discussion of the chemistry involved would set the scene. The extra stability and convenience resulting from using phenylamine in the form of its solid salt, rather than as the free liquid, should be covered. Also, the necessity of releasing phenylamine from its salt prior to use provides an opportunity to discuss strong acid / salt of weak acid reactions.

The exercise can be conducted in two parts, with a break after the completion of Step 8. This would allow time for the samples to dry properly.

If the melting point of the student's sample is to be used to check purity it is very important that:

- the sample is dry
- the students do not have prior knowledge of the melting point from other sources.

An element of competition can be introduced into the exercise by publicly sealing the melting point in an envelope. After all the students/groups have declared their melting points, the envelope is ceremoniously opened and a small prize is awarded to the winner.

The data book value for the melting point of *N*-phenylethanamide is 114–116 °C

**Note:** It might be worth spending a little time discussing the importance of acylation reactions in general and the production of polyamides in particular.

### Answers to questions

- The correct equation for the reaction occurring in stage 1 is.

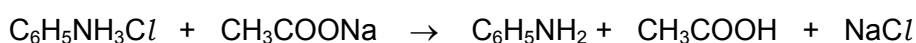

- The correct equation for the reaction between phenylamine and ethanoic anhydride is.

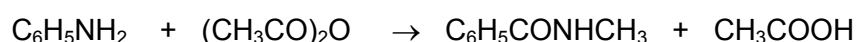

## Appendix 2

- The correct equation for the reaction between phenylamine and ethanoyl chloride is.

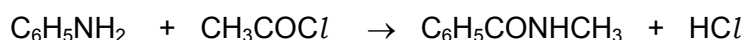

- For Question 13  
Maximum mass of *N*-phenylethanamide from 1.0 g of phenylammonium chloride = 1.04 g
- For Question 14  
The percentage yield will be consequential on the mass obtained by the student. A yield around 70% is good. If it is higher than this then the product is likely to be impure or damp.
- Melting points should be compared with the book value of 114–116 °C. Impure samples are likely to melt over a wide range, and at a temperature lower than 114–116 °C.

**Technical information**

Requirements per student/group

**Apparatus**

- spatula
- distilled water bottle
- three 250 cm<sup>3</sup> beakers
- small conical flask
- three boiling tubes
- 50 cm<sup>3</sup> measuring cylinder
- 10 cm<sup>3</sup> measuring cylinder
- glass stirring rod
- filtration apparatus, Buchner apparatus (preferred) or filter funnel
- filter papers appropriate for filtration apparatus supplied
- Bunsen burner
- tripod and gauze
- dropping pipette
- standard filter paper x 4"
- two sample tubes
- two small sticky labels
- eye protection
- access to melting point apparatus
- two melting point tubes
- access to weighing machine
- sight of Hazard card

**Materials**

Chemical samples should be kept in screw top bottles or sealed tubes.

- about 7 g of sodium ethanoate
- about 1 g of phenyl ammonium chloride
- about 2 cm<sup>3</sup> of ethanoic anhydride

### Safety

The main points are included on the Student Sheet. However, it is essential that a risk assessment be carried out before a decision is taken to go ahead with this exercise. MSDS sheets should be consulted so that the correct action can be taken in event of a spillage and/or accident. Materials that are harmful to the environment must be disposed of according to local regulations.

- It must be **made clear** to students that potentially hazardous materials are in use and that precautions are needed to minimise the risk to themselves and to others.
- Your **MUST** be prepared to **intervene** if a student seems to be unsure of a procedure, or is performing an unsafe operation.

## 29. Preparation of poly(pyrrole) (a conducting polymer)

### Student sheet

In this exercise, you are going to make a **conducting** polymer. You will then, using a circuit of your own devising, test its conductivity.

#### Intended lesson outcomes

By the end of this exercise you should be able to:

- handle hazardous materials safely
- work with delicacy and precision
- measure the conductivity of a polymer
- understand the polymerisation process and the concept of a conducting polymer

#### Background information

Electrical conductors work by allowing a flow of electrons through them. This requires that delocalised (mobile) electrons are present in the conductor. Metals conduct because they easily lose their outer shell electrons to form what may be described as a 'sea of delocalised electrons'. Graphite conducts owing to its bonding/structure; the carbon atoms form an extended system of  $\pi$  bonds which are delocalised across the whole plane of a graphite sheet. Consider the bonding in benzene. It may be thought of as having alternate double ( $\pi$  bonds) and single bonds ( $\sigma$  bonds). However, the benzene ring does not behave like an alkene. The reason is that an electron from each carbon atom is delocalised. The bonding in the ring is, therefore, described as being **delocalised**, and the mobile electrons are called **delocalised electrons**. Molecules with alternating double and single bonds are described as having a **conjugated system** of bonding. In a conjugated system, some electrons are delocalised and so can move freely throughout the conjugated system.

The structure of pyrrole,  $C_4H_5N$ , is shown below. You will notice that the two double bonds are conjugated. Also, there is a lone pair of electrons on the nitrogen atom that can also join in the conjugation so that together they provide six delocalised electrons, similar to those in benzene; see the diagrams below.

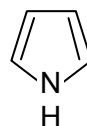
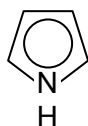

Under appropriate conditions, pyrrole polymerises to form poly(pyrrole), the structure of which is shown below.

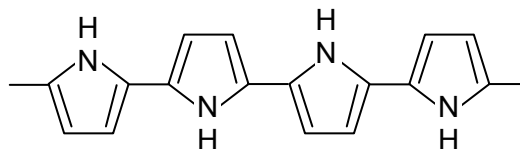
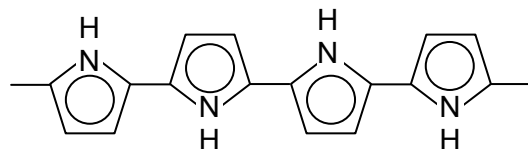





In both poly(pyrrole) and poly(ethyne),  $-(CH=CH)_n-$ , the delocalisation extends along the whole length of the polymer chain. However, in order to make such polymer chains conductors, electrons have to be added (reduction) or removed (oxidation) from the conjugated system. Electrons can then move along the polymer chain, through the conjugated system just as they do through graphite or a metal.

In this exercise, you will make some poly(pyrrole) by **growing** it on a nickel anode as a thin film. You will then remove this film by carefully peeling it off the anode, and test its conducting properties.

### Safety

There are potentially hazardous substances involved in this exercise. You **must** follow all health and safety instructions given to you by your teacher. Materials data safety sheets should be consulted so that the correct action can be taken in event of a spillage and/or accident.

	<b>You must wear eye protection throughout this experiment</b>
	Pyrrole is <b>toxic</b>
	Sodium 4-methylbenzenesulphonate is <b>irritant</b> and <b>harmful</b>
	Propanone is <b>highly flammable</b>

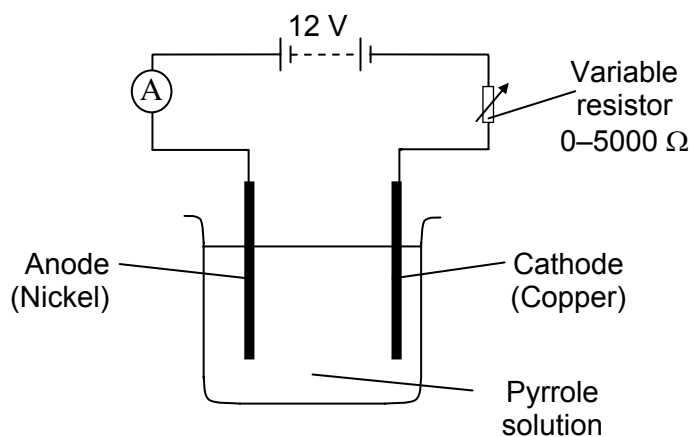

### Procedure

- Copper electrode:** Clean the piece of copper supplied with wire wool or emery paper and then rinse it with distilled water. Loop it over the side of the 250 cm<sup>3</sup> beaker so that it reaches the bottom.
- Nickel electrode:** Clean the flat end of a nickel spatula with a non-abrasive metal cleaner such as 'Brasso' (you will only be able to peel the polymer off if the nickel electrode is very **clean** and **smooth**). Rinse thoroughly with distilled water, and then with propanone. Allow the spatula to dry in the air.
- Do not touch the flat part of the spatula with your fingers once you have washed it.**
- Work in a fume cupboard. Using a teat pipette, drip about 0.4 g of pyrrole into a 250 cm<sup>3</sup> conical flask (**CARE: irritant**). If you **spill** any pyrrole on your hands, **wash** it off with **lots** of **water**.
- Add 100 cm<sup>3</sup> of sodium 4-methylbenzenesulphonate solution (concentration
- 0.100 mol dm<sup>-3</sup>) to the pyrrole. Swirl the flask thoroughly until the pyrrole has dissolved.
- Pour the pyrrole solution into the 250 cm<sup>3</sup> beaker and set up the circuit as shown in the diagram.
- Start with a low current and gradually increase it to 30 mA.

## Appendix 2

9. The nickel electrode should turn black within seconds and bubbles of hydrogen will form at the copper cathode.
10. Continue passing a current for about 45 minutes.
11. Remove the nickel electrode and wash it with water. Carefully peel off the poly(pyrrole) film in **one piece** using a scalpel or razor blade.

**Testing the conductivity of poly(pyrrole)**

1. Place your film on a glass slide. Fold the film in half and half again (four thicknesses) to reduce the possibility of it burning out when a current is passed through it.
2. Using crocodile clips, connect the film into a simple series circuit containing a 1.5 V bulb and a variable 12 V d.c. supply. Initially, place the crocodile clips about 5 cm apart and start with a p.d. of 2 V. Gradually increase the p.d. and then move the crocodile clips closer together. You should find that when the p.d. is 12 V and the crocodile clips are about 1 cm apart, the bulb will light.

**Question**

Suggest, with explanation, how the conductivity of poly(pyrrole) compares with that of copper, and with polymers such as poly(ethene) or nylon.

## 29. The preparation of poly(pyrrole) (a conducting polymer)

### Teachers' Notes

The exercise provides a novel way of preparing a polymer which, once formed, has unusual properties. To work properly, care and precision are required.

#### Intended learning outcomes

Please see the Student Sheet

#### A suggested approach

This is a relatively simple practical exercise but it does require great care and patience if it is to work properly. The chemicals used must be handled with care but the exercise is not beyond the capabilities of A level students.

The polymer is formed at the anode of an electrolytic cell, with hydrogen gas being evolved at the cathode. You may wish to revise the theory of electrolysis with your students prior to starting the exercise.

More able students may well deduce that  $H^+$  ions are being produced at the anode, along with the polymer, and that hydrogen atoms are being removed from the 2- and 4- positions on the pyrrole ring. Putting these two ideas together could well result in an interesting discussion of the polymerisation process.

The polymer film is quite fragile and will need to be handled carefully. Students should aim to remove it in one piece and then transfer it to a microscope slide for support. The crocodile clips used to connect the film into the circuit will also need to be carefully positioned if the film is not to be damaged.

It is normal for the teacher to trial experiments before using them with a class of students. The wise teacher will certainly trial this exercise!

#### Answers to question

The conductivity of the polymer is:

- lower than that of copper (copper doesn't need 12 V to light a 1.5 V bulb, so must have a much higher concentration of delocalised electrons)
- greater than Terylene and nylon (they are non-conductors due to the absence of delocalised electrons)

#### Technical information

Requirements per student/group

#### Apparatus

- copper foil (1 cm wide and long enough to be folded over the edge of a beaker and still reach to the bottom)
- nickel spatula
- one 250 cm<sup>3</sup> beaker
- one 250 cm<sup>3</sup> conical flask
- 0–5000  $\Omega$  variable resistor
- 12 V d.c. supply (2 V steps)
- ammeter range 0–30 mA
- 1.5 V light bulb and holder
- teat pipette
- razor blades or equivalent

## Appendix 2

- microscope slides
- access to fume cupboard
- crocodile clips
- wires

**Materials**

- pyrrole (0.4 g)
- 100 cm<sup>3</sup> of sodium 4-methylbenzenesulphonate (*p*-toluenesulphonic acid sodium salt) solution of concentration 0.10 mol dm<sup>-3</sup>
- propanone (20 cm<sup>3</sup>)
- wire wool or emery paper
- 'Brasso' metal polish
- small pieces of cloth
- paper towels

**Safety**

The main points are included on the Student Sheet. However:

- It is essential that a risk assessment is carried out before a decision is taken to go ahead with this exercise. MSDS sheets should be consulted so that the correct action can be taken in event of a spillage and/or accident.
- It must be **made clear** to students that potentially hazardous materials are in use and that precautions are needed to minimise the risk to themselves and to others.
- Your **MUST** be prepared to **intervene** if a student seems to be unsure of a procedure, or is performing an unsafe operation.



## 31. Separation techniques

### Student Sheet

In this exercise, you will have the opportunity to learn about four different techniques for separating substances in a mixture. All of these techniques are widely used in the outside world.

#### Intended lesson outcomes

By the end of this exercise you should be able to:

- use solvent extraction techniques and purify by recrystallising
- perform a titration and use a separating funnel
- determine a partition coefficient
- use and understand paper chromatography
- use and understand **two-way** chromatography
- use and understand electrophoresis
- understand amino acid structure and zwitterions





#### 1 Solvent extraction of caffeine from tea or coffee

##### Background information

Caffeine, a heterocyclic base ( $C_8H_{10}N_4O_2$ , m.p. 235–237 °C), is found in tea and coffee, and is also present in cola drinks. It is readily soluble in trichloromethane and so this solvent can be used to extract caffeine from an aqueous solution of caffeine. Both tea and coffee provide a ready source of caffeine but the extraction from tea goes more smoothly, since trichloromethane emulsions form less readily and there are fewer coloured impurities. The extraction of caffeine from the tea or coffee into water is 'solvent extraction'; the extraction of caffeine from the water layer into the trichloromethane layer is an example of 'partitioning'.

##### Safety

- Eye protection should be worn throughout the exercise
- Take care when handling the hot extract
- Points 11, 12 and 13 below **must** be performed in a **fume cupboard**

	You must wear eye protection throughout this experiment
	Lead ethanoate (lead acetate) is <b>toxic</b>
	Sulphuric acid and ammonia are <b>corrosive</b>
	Trichloromethane (chloroform) is <b>harmful</b>
	Lead ethanoate and ammonia are <b>dangerous for the environment</b>

**Procedure**

1. Weigh out about 50 g of tea or roast ground coffee, or 20 g of 'instant' coffee, and warm it in a beaker with 200 cm<sup>3</sup> of water, boiling gently for 15 minutes.
2. Remove the solids by filtering through muslin using, if possible, vacuum filtration; wash the solids with a little hot water and combine the washings with the original filtrate.
3. Heat the filtrate to boiling and add 100 cm<sup>3</sup> of aqueous lead ethanoate to precipitate any albumin and acids present.
4. Filter a small sample through a cotton-wool plug.
5. Use this small sample of your filtrate to check that the precipitation is complete by adding to it a little aqueous lead ethanoate. If any further precipitate forms, add more aqueous lead ethanoate to the original filtrate and repeat steps 4 and 5 until you are convinced that all albumin and acids have been removed.
6. Filter using, if possible, vacuum filtration, placing muslin over the filter paper to prevent clogging.
7. Add dilute sulphuric acid to the filtrate to precipitate all lead ions and remove the lead sulphate precipitate by filtration.
8. Add dilute aqueous ammonia to the filtrate until it is neutral to litmus.
9. Evaporate this solution to 100 cm<sup>3</sup>; allow to cool a little.
10. Add 5 g of decolourising charcoal and bring to the boil cautiously. Filter using, if possible, vacuum filtration to remove the charcoal.

**The steps which follow involve the use of trichloromethane and must be performed in a fume cupboard**

11. Using a separating funnel, extract the filtrate by adding a 40 cm<sup>3</sup> portion of trichloromethane and, rather than shaking vigorously (which may cause emulsification), invert the funnel frequently over a period of 30 seconds. Allow the layers to separate, and remove the lower trichloromethane layer. Repeat the process with a second 40 cm<sup>3</sup> portion of trichloromethane and combine it with the first trichloromethane extract.
12. Dry the trichloromethane solution by adding **anhydrous sodium sulphate**; leave the mixture to stand for 15 minutes, or longer if possible, and then filter it.
13. Distil off most of the trichloromethane, and then evaporate the remaining solution to dryness in a beaker on a water-bath **in a fume cupboard**. About 1 g of caffeine should remain.

**Purification**

14. Recrystallise from the **minimum volume** of hot water.
15. Assess the purity of your sample of caffeine by determining its melting point. Compare your value with the data book value of 235–237 °C.

**Question**

Suggest why it is an advantage that emulsions form less readily when using tea as the source of caffeine.

## 2 Partition coefficients – the distribution of iodine between hexane and water

### Background information

If a solute is added to a mixture of two immiscible solvents then the solute will dissolve in both solvents. The degree to which the solute dissolves in each solvent will depend on the solubility of the solute in each solvent. It is unlikely, therefore, that the concentration of the solute will be the same in both solvents. The ratio between these two concentrations is known as the **partition coefficient**.

Iodine is soluble in both water and hexane. Water and hexane are immiscible (they do not mix to any appreciable degree) so, when they are both added to a flask, two layers are formed; water forms the bottom layer as it is more dense than hexane. If solid iodine is added to this beaker, it dissolves in both solvents, forming an orange/yellow colour in the water and a darker red/purple colour in the hexane.

As the solid iodine falls to the bottom of the beaker, it dissolves first in the water. Slowly, the colour in the hexane layer develops as iodine moves from the water layer into the hexane layer. Shaking the mixture can accelerate this process. Eventually, the colours stabilise and equilibrium is reached.

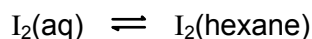

At the interface between the two solvents (the solvent boundary) iodine is continually moving backwards and forwards between the two solvents. The rate at which iodine move from hexane to water will eventually become equal to the rate of iodine moving in the opposite direction. Thus, an equilibrium is established.





The equilibrium constant for this process is shown below. The subscripts after the equilibrium constant symbol,  $K$ , define the solvents used, i.e. 'h' = hexane and 'w' = water, and 'hw' showing that the order of the concentration ratio.

$$K_{hw} = \frac{[\text{I}_2(\text{hexane})]}{[\text{I}_2(\text{aq})]}$$

### Safety

Materials data safety sheets should be consulted so that the correct action can be taken in event of a spillage and/or accident

- Take care when handling the hot extract.

	<b>You must wear eye protection throughout this experiment</b>
	Hexane is <b>highly flammable</b> ,
	<b>harmful</b>
	and <b>dangerous to the environment</b> . Your teacher will tell you how to dispose of it safely

**Procedure**

1. Measure 30 cm<sup>3</sup> of hexane and 30 cm<sup>3</sup> of water into a 100 cm<sup>3</sup> conical flask.
2. Add about 1 g of iodine crystals to the flask, insert the bung and shake the mixture until the colour in each layer is stable.
3. Decant the mixture into a separating funnel and run off the two layers into separate 100 cm<sup>3</sup> beakers.
4. Using a pipette, transfer a 25.0 cm<sup>3</sup> portion of the aqueous solution of iodine to a 250 cm<sup>3</sup> conical flask.
5. Fill the burette with the solution of sodium thiosulphate provided.
6. Titrate the aqueous solution against the sodium thiosulphate solution. Add starch when the solution is a pale straw colour.
7. Repeat the titration using the hexane solution. Before you start this titration, add about 10 cm<sup>3</sup> of distilled/deionised water. You will need to shake the flask after each addition and allow time for the iodine to transfer from the hexane into the aqueous sodium thiosulphate layer. At the end of this titration the hexane layer will be colourless.
8. Record your results in an appropriate table.

**Note:** great care should be taken with the titrations, as you will not be able to repeat them.

**Calculation**

As equal volumes of the two solutions were titrated, the ratio of the titres will be equal to the ratio of the concentrations of iodine in the two solvents. Therefore:

$$K_{hw} = \frac{[I_2(\text{hexane})]}{[I_2(\text{aq})]} = \frac{\text{titre value for hexane solution}}{\text{titre value for aqueous solution}}$$

### 3 Chromatography – the chromatographic separation of amino acids

#### Background information

The experiment is designed to give you experience and understanding of an important analytical chemical tool. To completely separate and identify some materials, for example amino acids, by paper chromatography might take several days, so this brief exercise can only suggest the potentialities of the method.

You are to separate a mixture of dyes or other organic molecules. If the components of the mixture you are separating are colourless, you will need to treat your chromatogram after the separation in order to detect the spots.





If chromatographic separation is to work effectively, it is essential that:







- the spots are small and not overloaded with material
- no spot is placed less than 1.5 cm away from the side or bottom edges
- spots are dry before adding more solution (if the solution used is very dilute), or before standing the paper cylinder in the solvent
- the edges of the cylinder must not touch
- the solvent level must be below the bottom of the spots
- to maintain a saturated atmosphere, the container must be covered
- the paper is only handled by its edges, preferably by gloved hands, and is only placed down on clean blotting paper, NOT on the bench top. Any contamination on the paper, either liquid or solid, will ruin the chromatogram
- when developed, the solvent front must be marked; the paper must be **thoroughly** dried (an oven produces better results than air drying) and then, if required, **lightly** sprayed
- each spot on the chromatogram is outlined in pencil, as the spots may fade with time

Clearly then, to obtain satisfying results you will have to work with care and keep the experimental materials scrupulously clean. Touch the chromatography papers only on their top corners and never lay them down except on a clean sheet of blotting paper.

#### Safety

Depending on which mixture you are working with different risks will apply. There are potentially hazardous substances involved in this exercise and so you must follow all health and safety instructions given to you by your teacher. Operations requiring the use of a fume cupboard **MUST** be done in a fume cupboard. Materials data safety sheets should be consulted so that the correct action can be taken in event of a spillage and/or accident.

	<b>You must wear eye protection throughout this experiment</b>
	Ethanol and propanone are <b>highly flammable</b>
	Methanol is <b>flammable</b>
	and <b>toxic</b>
	Hydrochloric acid, nitric acid and glacial ethanoic (acetic) acid are <b>corrosive</b>

	Butan-1-ol, ninhydrin and copper(II) nitrate are <b>harmful</b>
	Ammonia is <b>corrosive</b>
	and <b>harmful</b>
	Petroleum spirit is <b>harmful</b>
	and <b>highly flammable</b>
	Copper(II) nitrate and ammonia are <b>dangerous for the environment</b> . Your teacher will tell you how to dispose of them safely.

### Procedure

- Put spots of your solutions 1.5 cm from the bottom edge of the chromatography paper (cut to the dimensions shown in the diagram) and well spaced out. To do this, dip a **clean** capillary tube in the stock solution and apply a small drop to the chromatography paper, using a quick delicate touch. Practise on a piece of ordinary filter paper until you can produce spots **not more than 0.5 cm** in diameter. You should not place a spot less than 1.5 cm from the edge of the paper.

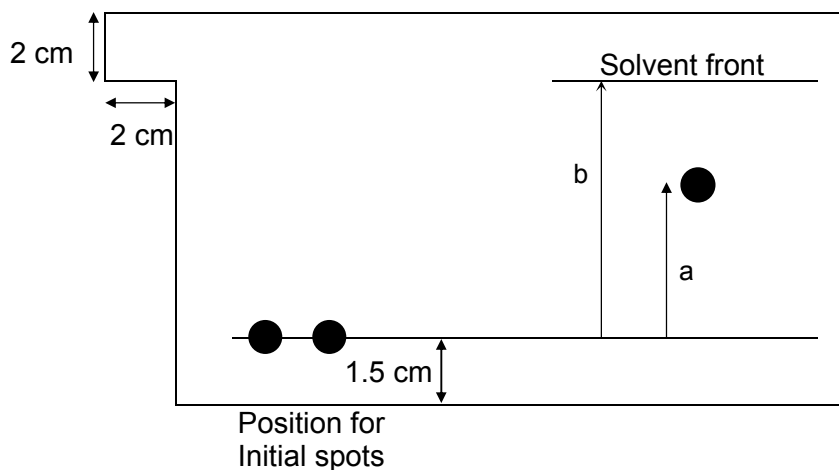

- Make identification marks in **pencil** at the top of the paper above each spot.
- Allow the spots to **dry** thoroughly. If you need to add more material to a spot, you must let the spot **dry before** applying a second small drop of the solution. Otherwise, the size of the spot will grow too large.
- Place the solvent mixture you are to use in a 1 dm<sup>3</sup> beaker; covering the beaker to produce a saturated atmosphere. The depth of the solvent in the beaker **must be below** the bottom of each spot on the paper when the paper is in place.
- Roll the chromatography paper into a cylinder and secure it with a paper clip. The 'tab' shown in the diagram allows you to clip the two ends of the paper together **without** the two sides below the tab **touching**. If they do touch, the solvent will not 'run' properly at the edges of the paper.
- Stand the cylinder in the covered solvent beaker and leave it for the solvent to ascend to nearly the top of the paper. If time is limited, you may not be able to allow the solvent to rise the full distance.
- Remove the chromatography paper from the beaker and **mark** the solvent level.
- Dry the paper (without unfastening it), in an oven if possible, but **not** over a Bunsen flame, as many of the solvents used are pungent, flammable or both.
- It may be necessary to 'detect' the substances in your mixture. If this is the case, follow the instructions given in the table below.
- Determine the  $R_f$  (relative front) values for the components in your sample.  $R_f$  values should be constant, providing standard conditions are used, and are obtained by using the expression:

$$R_f = \frac{\text{distance moved by sample}}{\text{distance moved by solvent front}} = \frac{a}{b}$$

**Note:** When a mixture of amino acids is separated using **one-way** chromatography, as described above, the separation is incomplete. The full separation of all the amino acids

## Appendix 2

requires the use of **2-way** chromatography, in which the chromatogram is developed in one direction in one solvent system, followed by a second development at right angles to the first in a different solvent system.

To use **two-way** chromatography:

1. Using square chromatography paper, spot your sample in the **bottom-right-hand** corner of the paper, about 3 cm from the corner.
2. Allow it to dry, roll the chromatography paper into a cylinder and place it in the first solvent system.
3. When the solvent has reached almost to the top of the paper, allow the paper to dry thoroughly.
4. Re-roll and clip the paper so that the original spot is at the **bottom-left-hand** corner.
5. Develop the paper using the second solvent system.
6. When complete, dry the paper thoroughly and detect the amino acids by spraying with ninhydrin, as for the **one-way** process.

If **two-way** chromatography is to be successful, cleanliness is crucial. Cover your workbench with clean blotting paper, wear gloves, and only handle the paper by its edges.



## Experiments

Use the materials given in the table below, and the instruction given above, to complete the task you have been set.

mixture	preparation	solvent system	detection
ink	<ul style="list-style-type: none"> <li>ballpoint pen, use ink straight</li> <li>coloured inks, dilute 1:3 with water</li> </ul>	<p><b>Solvent system A</b> water (15 cm<sup>3</sup>); saturated ammonium sulphate (2 cm<sup>3</sup>); ethanol (3 cm<sup>3</sup>) <b>or</b> <b>Solvent system B</b> methanol (15 cm<sup>3</sup>); concentrated hydrochloric acid (2 cm<sup>3</sup>); water (2 cm<sup>3</sup>)</p>	<p>No further treatment is required.</p> <p>Compare the effectiveness of the two solvent systems, <b>A</b> and <b>B</b>, in separating your inks.</p>
Amino acids	<p>Prepare solutions (0.01 mol dm<sup>-3</sup>) of the amino acids to be tested.</p> <p>For <b>one-way</b> chromatography, just use solvent system <b>C</b>.</p> <p>For <b>two-way</b> chromatography use solvent system <b>C</b> and then solvent system <b>D</b>.</p> <p>In both cases, detect and then preserve the spots produced.</p>	<p><b>Solvent system C</b> butan-1-ol (12 cm<sup>3</sup>); glacial ethanoic acid (3 cm<sup>3</sup>); water (6 cm<sup>3</sup>)</p> <p><b>Solvent system D</b> ethanol (36 cm<sup>3</sup>); '0.880' ammonia (2 cm<sup>3</sup>); water (2 cm<sup>3</sup>)</p>	<ul style="list-style-type: none"> <li>Spray sparingly with aqueous ninhydrin (0.02 mol dm<sup>-3</sup>) <b>in a fume cupboard</b>.</li> <li>Heat in an oven at 110 °C for 10 mins.</li> <li>The amino acid spots will be purple.</li> <li>Preserve the spots by spraying with the following mixture: copper(II) nitrate (1.0 mol dm<sup>-3</sup>) (1 cm<sup>3</sup>); methanol (19 cm<sup>3</sup>); nitric acid (2 mol dm<sup>-3</sup>) (1 drop).</li> <li>Expose to the fumes from '0.880' aqueous ammonia <b>in a fume cupboard</b>.</li> <li>The background will be blue and the spots orange.</li> </ul>
chlorophylls etc.	<ul style="list-style-type: none"> <li>Grind about 1 g of fresh nettle leaves (or similar) with sand.</li> <li>Soak in 5 cm<sup>3</sup> propanone for 5 minutes and filter into a separating funnel, using a cotton-wool plug.</li> <li>Add 5 cm<sup>3</sup> of petroleum spirit, shake, remove top layer and dry it using anhydrous sodium sulphate.</li> </ul>	<p>petroleum spirit (40–60 °C) (17 cm<sup>3</sup>); propanone (3 cm<sup>3</sup>)</p>	<p>No further treatment is necessary although exposure to UV light may assist visualisation.</p> <p>Colours, from top:</p> <ul style="list-style-type: none"> <li>carotene</li> <li>phaeophytins</li> <li>xanthophylls</li> <li>chlorophyll A</li> <li>chlorophyll B</li> </ul>

## Appendix 2

Smarties, M&Ms or similar	<ul style="list-style-type: none"> <li>Using a moist artist's paintbrush, remove colour from the surface.</li> <li>Spot onto chromatography paper.</li> </ul>	water	none
organic acids	<ul style="list-style-type: none"> <li>Prepare solutions (<math>0.05 \text{ mol dm}^{-3}</math>) of the sodium salts of the organic acids to be tested.</li> </ul>	Shake together butan-1-ol ( $30 \text{ cm}^3$ ) and $1.5 \text{ mol dm}^{-3}$ aqueous ammonia ( $30 \text{ cm}^3$ ). Use the upper, organic layer ( $20 \text{ cm}^3$ ).	Spray <b>lightly</b> with bromothymol blue [ $0.1 \text{ g}$ in $0.01 \text{ mol dm}^{-3}$ NaOH ( $1.6 \text{ cm}^3$ ) diluted to $100 \text{ cm}^3$ ]. <ul style="list-style-type: none"> <li>background – green</li> <li>acids – yellow</li> </ul>

#### 4 Electrophoresis – the separation of amino acids

##### Background information

In an electrolytic cell, positive ions are attracted to the cathode, while negative ions move towards the anode. The current is carried through the electrolyte by the ions. At the electrodes, electrons are transferred to or from the ions. The overall reaction is a redox reaction.

Electrophoresis works in essentially the same way. A piece of filter paper is soaked in an electrolyte and connected into a d.c. circuit using crocodile clips. A mixture of ions is spotted into the centre of the paper and the circuit is switched on. The positive ions migrate towards the cathode and the negative ions towards the anode. The rate at which different ions will migrate will vary according to the mass, charge and shape of the ions; thus different ions are separated as they migrate. The distance which each amino acid moves, under controlled conditions of pH and electric field, can be measured and compared with standard values.

This technique is particularly useful in the separation of amino acid and protein mixtures. The structure of an amino acid is shown below. However, amino acids predominantly take the form of a **zwitterion**, that is a double ion which is neutral overall. In alkaline solution the  $\text{-NH}_3^+$  ion is deprotonated, leaving the molecule negatively charged overall and in acid solution the  $\text{-COO}^-$  group is protonated, leaving the amino acid positively charged overall.

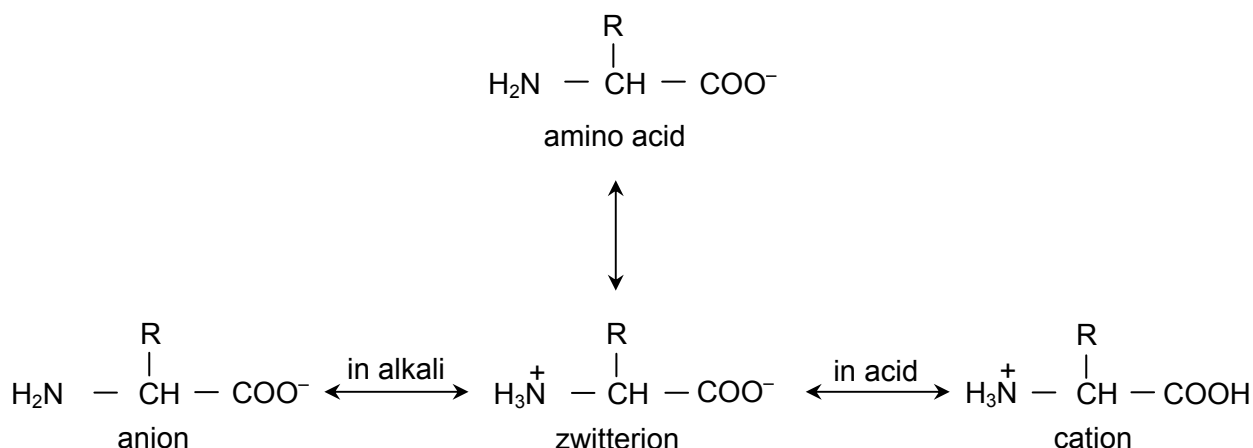









In an electrophoresis experiment a molecule that is uncharged will not move towards either pole. The R group of the simplest amino acid, glycine, is simply H, so the only groups affecting its movement are the  $\text{NH}_3^+/\text{NH}_2$  and  $\text{COO}^-/\text{COOH}$  groups. But many other amino acids have charged side chains, for example arginine has an amino group, and these groups will affect the overall charge of the molecule. These differences in charge can be used to separate amino acids in the electrophoresis experiment. At neutral pH, glycine will not be charged and will not move in an electric current, but arginine will be positively charged owing to its side chain, and will move towards the cathode.

For each amino acid there is a pH at which its overall charge will be neutral and it will not move in an electric current. This is termed its "isoelectric point" or "pI" value. You would expect the pI value of glycine to be 7 (neutral). In actual fact it is closer 6, although it will only move very slowly at pH 7.

In this experiment you will investigate the effect of pH on the movement of different amino acids in an electrophoresis experiment.

**Safety**

Point 9 requires the operation to be performed in a fume cupboard.

	<b>You must wear eye protection throughout this experiment</b>
	Ninhydrin and copper(II) nitrate are <b>harmful</b>
 	Methanol is <b>highly flammable</b> and <b>toxic</b>
	Nitric acid is <b>corrosive</b>
 	Ammonia is <b>corrosive</b> and <b>harmful</b>
	Copper(II) nitrate and ammonia are <b>dangerous to the environment</b> . Your teacher will tell you how to dispose of them safely.

**Procedure**

- 1 Draw a faint pencil line across the middle of a strip of filter paper and mark the ends negative and positive. Place the paper on top of a sheet of glass.
- 2 Soak the paper with the pH 6 buffer solution.
- 3 Spot the mixture containing lysine, glycine and glutamic acid onto the pencil line.
- 4 **Carefully** attach crocodile clips to each end of the paper, taking care to attach the negative and positive correctly.
- 5 Cover the paper with a large beaker for protection.
- 6 Connect the wires to a 100 V d.c. supply and pass current for 30 minutes.
- 7 Dry the paper carefully.
- 8 Detect the amino acid spots by spraying the paper with ninhydrin.
- 9 Preserve the spots by spraying the paper with a mixture of 1.0 mol dm<sup>-3</sup> copper(II) nitrate (1 cm<sup>3</sup>), methanol (19 cm<sup>3</sup>) and 2 mol dm<sup>-3</sup> nitric acid (1 drop), followed by exposure to the fumes from '0.880' aqueous ammonia **in a fume cupboard**.

**Questions**

- 1 How would you expect glycine to move? Explain your answer.
- 2 In which direction would you expect lysine and glutamic acid to move? Explain your answer.
- 3 Identify the glycine, lysine and glutamic acid spots on your electrophoresis paper.

**Procedure (continued)**

- 10 Repeat the experiment using the same mixture but different pH buffers.
- 11 Repeat the experiment using different mixtures of amino acids.

**Question**

- 4 What difference, in terms of the movement of amino acids, do you observe when different pH buffers are used? Account for these differences.

## 31. Separation techniques

### Teachers' Notes

This exercise contains a suite of four experiments designed to give practice in a range of separation techniques. It is suggested that the experiments are performed as a **circus**, perhaps over several weeks. The basic techniques involved are relatively straightforward but great emphasis must be placed on safety, as there are hazards associated with several of the solvents used. The use of a fume cupboard is necessary in some instances. If fume cupboard facilities are limited, it may be better to perform the experiments separately, rather than as a circus, so that attention can be focussed on one process at a time. The use of demonstration might be considered; however, a hands-on approach will make the techniques more memorable to the students.

#### 1 Solvent extraction

The 'kitchen sink' nature of this experiment is appealing to students. The basic extraction into water is a simple extension of what happens each time we make a cup of tea or coffee. The extraction into trichloromethane, however, carries some risk and **must** be performed in a fume cupboard.

#### Extension exercises

If suitable apparatus is available,

- the recrystallised caffeine may be further purified by **column chromatography** using an alumina column. The solvent mixture to use in this process is benzene (3 parts) and trichloromethane (1 part);
- compare the purified sample with a commercial sample of caffeine by **chromatography** on a silica gel slide. Develop the slide using a solvent mixture comprising of trichloromethane (9 parts) and ethanol (1 part). Detect the spots by exposing to iodine vapour.

This extension provides a useful overlap between solvent extraction and chromatography, and provides experience in column chromatography and in TLC (Thin Layer Chromatography).

#### Answer to question

Emulsions take time, often a long time, to settle and separate into layers. If no emulsion is formed, the two layers form rapidly.

#### Technical Information

Requirements per student/group

#### Apparatus

- two 500 cm<sup>3</sup> glass beakers.
- tripod, gauze, Bunsen burner
- vacuum filtration kit – if possible, otherwise use gravity filtration
- glass filter funnel
- a piece of muslin cloth
- cotton-wool
- filter papers
- two 100 cm<sup>3</sup> measuring cylinders
- one large evaporating dish
- one 250 cm<sup>3</sup> separating funnel
- apparatus suitable for carrying out a distillation
- water bath

- melting point apparatus

### Materials

- Access to  $0.30 \text{ mol dm}^{-3}$  aqueous lead ethanoate
- Access to  $2 \text{ mol dm}^{-3}$  sulphuric acid
- Access to  $2 \text{ mol dm}^{-3}$  aqueous ammonia
- Litmus paper
- Activated charcoal
- Access to trichloromethane
- Access to anhydrous sodium sulphate

## 2. Partition coefficients

This experiment is quite easy to perform and is satisfyingly 'visual'. Students will **see** that the colour in the hexane layer is darker than that in the aqueous layer, and so deduce a difference in solubility. The quantitative analysis which follows later will confirm that iodine is much more soluble in hexane than in water.

You may have to explain why, as this is a titration exercise, it is not necessary to calculate the iodine concentrations. More able student should deduce this intuitively. However, if you wish to practice mole calculations, the concentrations in each solvent could be calculated and their ratio obtained. The fact that the concentration ratio is the same as the ratio of the titres could then be used as a basis for the discussion of the basic theory involved. This should help those students whose understanding of this area is less secure.

### Technical Information

Requirements per pupil/group

#### Apparatus

- one spatula
- two  $50 \text{ cm}^3$  measuring cylinders
- two  $100 \text{ cm}^3$  beakers
- one  $100 \text{ cm}^3$  conical flask + bung
- one  $250 \text{ cm}^3$  conical flask
- one separating funnel
- one burette
- one funnel
- one  $25.0 \text{ cm}^3$  pipette and pipette filler

#### Materials

- access to solid iodine
- access to hexane
- a supply of distilled/deionised water
- access to 1% starch solution
- a supply of aqueous sodium thiosulphate

The concentration of this solution will, to some measure, depend on the ambient room temperature, as the solubility of iodine is temperature dependent, and on the time allowed for the iodine to dissolve. When you trial the experiment, start with a concentration of  $0.100 \text{ mol dm}^{-3}$  but be prepared to change this in the light of experience.

Iodine is much more soluble in hexane than in water, therefore the amount of sodium thiosulphate required to react with the iodine dissolved in the aqueous layer will be **much smaller** than that needed to react with the iodine dissolved in the hexane layer. The sodium

thiosulphate concentration should be such that the titre with the hexane solution is **not greater than the capacity** of the burette.

When titrating the aqueous layer, two possibilities exist. Either:

- (i) use a diluted solution of the original stock aqueous sodium thiosulphate or
- (ii) use the original stock aqueous sodium thiosulphate solution

The advantage of (i) is that the titre value can, by appropriate dilution, be arranged to be similar to that in the hexane titration, thus minimising the burette error factor; however, the dilution process will introduce an additional error factor. Also, the students will have to be supplied with two different solutions of sodium thiosulphate, with the danger that they will use the wrong one for a given titration, and will have to change from one to the other during the experiment.

The advantage of (ii) is that the same stock solution is used, so that dilution is not necessary and there is no need for students to change solutions; however, the titre obtained will be **much smaller** than that for the hexane titration and so the burette error factor will be **much more significant**.

If method (i) is used, the dilution factor will have to be determined when you trial the experiment; it is likely to be around a dilution factor of 10. It is crucial that this dilution is performed accurately. A burette or pipette must be used to measure the volume of the stock solution into a volumetric flask, which is then made up to the mark with distilled/deionised water. The volumetric flask must then be inverted several times to ensure thorough mixing. The diluted solution must be made up in **one batch** and the volume prepared must be sufficient for the needs of all the students who need to use it.

If method (ii) is used, the concentration of the stock solution should be such that the titre with the hexane solution is **not greater than the capacity** of the burette nor is the titre with the aqueous solution **too small**. Again, this concentration should be determined when you trial the experiment.

The actual concentration of the stock solution is not critical, as it is the ratio of the titre values which gives the  $K_{\text{hw}}$  value; appropriately scaled if method (i) is used. What **is critical** is that, in method (ii), the **same stock solution** is used for both titrations or, in method (i), that the dilution factor is accurately known.

**Note:** Arguably, method (i) will give the more reliable/accurate results, but method (ii) is more straightforward. For this reason, method (ii) has been used when writing the instructions on the Student Sheet. Students could be asked to discuss the errors in each method and decide themselves which to use.

### 3 Chromatography

This experiment provides a range of chromatographic opportunities, ranging from the fun 'Smartie'/'M&M' experiment, where the colours on the outer sugar shell are separated, to the much more complex **two-way** chromatographic separation of amino acids. The solvent and spray systems used in some separations use hazardous chemicals, and so great care must be taken to ensure that safety is not compromised.

It is worth practising the techniques involved using filter paper before using the more expensive chromatography paper. Some paper, e.g. 'Whatman CRT/1 paper', has vertical slits cut into it in order to physically separate the different mixtures being tested; such paper works well.



## Technical Information

Requirements per student/group

### Apparatus

- chromatography paper
- scissors
- capillary tubes
- paper clips or stapler
- 1000 cm<sup>3</sup> tall-form beaker / suitable jar with a screw top
- watch glass, or similar, to cover beaker
- access to an oven (around 110 °C) or hair dryer etc
- blotting paper to cover working area
- 100 cm<sup>3</sup> beakers – one for each solvent system to be used
- access to fume cupboard facilities

### Materials

- Solvent systems – as listed in the table on the Student Sheet. These could be premixed, or experienced students could make their own mixtures. If this is the case, measuring cylinders and beakers will have to be made available.
- access to appropriate solutions for detecting and protecting the spots – as listed in the table – in spray bottles
- 0.880 ammonia (concentrated ammonia) solution

## 4 Electrophoresis

It is worth emphasising to your students the importance of this process in normal life, e.g. in 'DNA fingerprinting' and in separating fragments in gene analysis. A simple introduction to this process is provided by the electrophoresis of metal ions; two examples of which are given below:

- (i) A potassium manganate(VII) crystal is placed at the centre of paper moistened with water.
- (ii) Aqueous silver nitrate is placed at the positive end of the paper (moistened with water), with aqueous potassium chromate(VI) at the negative end.

A 20 V smoothed d.c. supply is used. In (i), the movement of the purple  $\text{MnO}_4^-$  ions can be tracked, and reversed, if the polarity of the paper is reversed. In (ii), the movement of yellow  $\text{CrO}_4^{2-}$  ions can be followed until they meet  $\text{Ag}^+$  ions and form a red precipitate of  $\text{Ag}_2\text{CrO}_4$ . Details may be found in 'The migration of ions' (Experiment number 34, 'Classic Chemistry Experiments', RSC).

As this experiment uses water, rather than buffer solutions, and the progress of the migrating ions can be followed visually, you may wish to consider using this before tackling amino acid mixtures.

### Answers to questions

- 1 Glycine has a neutral side chain so will not move at pH 6 because it is in its zwitterionic form and there are no other charges.
- 2 Lysine has a positively charged side chain in solution at pH 6 and so will move towards the negative pole. Glutamic acid has a negatively charged side chain in solution at pH 6 and so will move towards the positive pole.
- 3 Glycine on start line, glutamic acid towards positive pole, lysine towards negative pole.

## Appendix 2

- 4 In an acid buffer, the  $\text{-COO}^-$  groups of the zwitterions are protonated. The charge on an amino acid with a neutral side chain is dominated by the  $\text{-NH}_3^+$  groups and hence will move towards the negative pole. Conversely in an alkaline buffer the  $\text{-NH}_2$  groups are no longer protonated and so an amino acid with a neutral side chain will have an overall negative charge owing to the  $\text{-COO}^-$  group and will move towards the positive pole. The effect on amino acids with charged side chains will be in the same direction but modified by the charge on the side chain.

### Safety

The main points are included on the Student Sheet. However:

- It is essential that a risk assessment be carried out before a decision is taken to go ahead with this exercise.
- It must be **made clear** to students that potentially hazardous materials are in use and that precautions are needed to minimise the risk to themselves and to others.
- Your **MUST** be prepared to **intervene** if a student seems to be unsure of a procedure, or is performing an unsafe operation.
- MSDS sheets should be consulted so that the correct action can be taken in event of a spillage and/or accident. Any materials dangerous to the environment should be disposed of according to local regulations.

A number of ways in which the exercise may be made less hazardous and more likely to succeed include:

- (i) Preparing the solvent and spray mixtures yourself and supplying them to the students in suitably labelled containers.
- (ii) Providing adequate access to fume cupboard facilities. This may mean scheduling the exercises so that demand for the fume cupboards is staggered.
- (iii) Demonstrating some of the techniques, particularly the spraying of a developed chromatogram.
- (iv) Telling the students that their safe working practices are being **assessed**; whether this is true or not!

### Technical Information

Requirements per student/group

#### Apparatus

- filter paper / chromatography paper
- glass plates – microscope slide would do but larger plates would be better
- scissors
- capillary tubes
- large beaker to cover the paper/glass
- two crocodile clips and wires
- a smoothed 100 V (d.c.) supply
- access to an oven (around 110 °C) or hair dryer etc
- blotting paper to cover working area
- 100 cm<sup>3</sup> beakers – one for each buffer solution to be used
- access to fume cupboard facilities

#### Materials

- access to the mixtures to be tested e.g. a mixture of glycine, lysine and glutamic acid
- access to appropriate buffer solutions. It is suggested that a pH 7 buffer, together with an acidic buffer (pH 6 or pH 5) and an alkaline buffer (pH 8 or pH 9) are used.

## Appendix 2

- access to ninhydrin in a spray bottle
- access to a solution containing  $1.0 \text{ mol dm}^{-3}$  copper(II) nitrate ( $1 \text{ cm}^3$ ), methanol ( $19 \text{ cm}^3$ ) and  $2 \text{ mol dm}^{-3}$  nitric acid (1 drop), in a spray bottle
- $0.880 \text{ mol dm}^{-3}$  ammonia (concentrated ammonia) solution